

# PARTS CATALOGUE CATALOGO DE REPUESTOS

## F80CED'10 (6CK2)

1J6CK-300F1

( )



2019/8/27

NEWS NO.	DATE	COMMENT
PE0-OM-110050	Dec.,22,2011	MOD:FIG.6 INTAKE 1 LIST REVISION
PE0-OM-150025	Sep.,1,2015	COR:FUEL INJECTION PUMP 1 ILLUSTRATION CORRECTION
PE0-OM-160006	Apr.,11,2016	MOD:F80C FUEL LIST/ILLUSTRATION REVISION
PE0-OM-190029	Aug.,21,2019	MOD:FIG.4 CYLINDER & CRANKCASE 2 LIST REVISION

F80CED  
PARTS CATALOGUE  
©2009 by Yamaha Motor Co., Ltd.  
1st edition, June 2009  
All rights reserved.  
Any reprinting or unauthorized use  
without the written permission of  
Yamaha Motor Co., Ltd.  
is expressly prohibited.  
Printed in Japan.

F80CED  
CATALOGUE DE PIECES DETACHEES  
©2009 par Yamaha Motor Co., Ltd.  
1<sup>re</sup> édition, juin 2009  
Tous droits réservés  
Toute réimpression ou utilisation  
non autorisée sans la permission écrite  
de la Yamaha Motor Co., Ltd.  
est formellement interdite.  
Imprimé au Japon

# FOREWORD

This Parts Catalogue is related to the parts for the model(s) on the cover page. When you are ordering replacement parts, please refer to this Parts Catalogue and quote both part numbers and part names correctly.

1. Modifications or additions which have been made after the issue of the Parts Catalogue will be announced in the Parts News. It is advisable that you make the necessary corrections to the Parts Catalogue according to the Parts News.

2. Abbreviations  
The following abbreviations are used in this Parts Catalogue.

“UR” Use specified parts number.  
 “UN” Use as many as needed.  
 “AP” Alternate Parts  
 “LM” Locally Made (Parts need to be ordered locally)  
 “F#” Frame No. (Applicable machine No.)  
 “O/S” Over Size

3. The number of components for assembly
  - Parts, which are to be supplied in an assembly, are listed with a dot (.) in front of the part name as shown below.
  - The numeral appearing to the right of each component part indicates the quantity of parts for each assembly unit.

PART NO.	DESCRIPTION	Q'TY	REMARKS
2F5-83310-60	FRONT FLASHER LIGHT ASSY	2	
115-83311-60	.BULB (6V-18W)	1	

4. Applicable colours of graphics are represented in the “REMARKS” as shown below.

PART NO.	DESCRIPTION	Q'TY	REMARKS
2N4-24110-00-X5	FUEL TANK COMP.	2	MXR
3J1-24240-10	.GRAPHIC, FUEL TANK	1	FOR MXR

5. Note that the illustrations for reference in finding parts numbers are not to be used for assembling. When assembling, please use the applicable service manual.

6. The asterisk (\*) before a reference number indicates modified items after the first edition.
7. Applicable Serial No.

Engine Serial No.

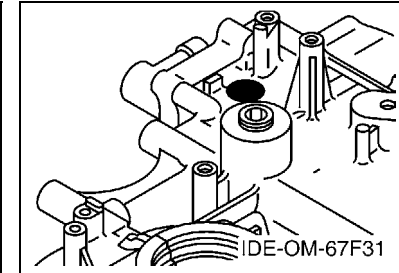
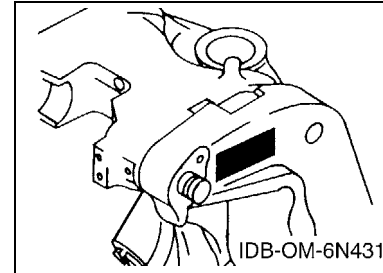

8. Applicable Engine Starting Serial No.

Model	Serial No.	Model	Serial No.
F80C	6CK-1000026		

9. Applicable Colour Code

Abbreviation	Colour Name	Colour Code
DBN1	DARK BLUISH GRAY 1	008D

10. Quantity Column Information

Column No.	Name Of Q'ty Column	Applicable Model
1	6CK2	F80CED

# AVANT-PROPOS

Ce catalogue de pièces détachées concerne les pièces pour le(s) modèle(s) indiqué(s) sur la page de couverture. Lorsque vous commandez des pièces de rechange, veuillez vous référer à ce catalogue de pièces détachées et indiquer clairement les numéros et les noms des pièces détachées.

1. Les modifications ou ajouts ayant été effectués après la parution du catalogue de pièces détachées seront décrits dans les Bulletins d'information concernant les pièces détachées.  
Il est recommandé que vous apportiez les corrections nécessaires au catalogue des pièces détachées en vous référant aux Bulletins d'information.

## 2. Abréviations

Dans ce catalogue, les abréviations suivantes sont utilisées:

- “UR” Utiliser le numéro de pièces spécifié.
- “UN” Utiliser autant que nécessaire.
- “AP” Pièces de substitution
- “LM” Fabrication locale (les pièces doivent être commandées localement.)
- “F#” N° de cadre (applicable au N° de série)
- “O/S” Surdimensionné

## 3. Nombre de pièces d'un assemblage

- Les pièces fournies comme composants d'un assemblage sont précédées d'un point (.) de la manière indiquée ci-dessous.
- Le chiffre apparaissant à la droite de chaque composant indique la quantité de pièces pour chaque unité d'assemblage.

N° PIECES	DESCRIPTION	QTE	REMARQUES
2F5-83310-60	ENS. CLIGNOTANT AVANT	2	
115-83311-60	.AMPOULE (6V-18W)	1	

4. Les couleurs concernant les graphiques sont indiquées dans la colonne “REMARQUES”, comme indiqué ci-dessous.

N° PIECES	DESCRIPTION	QTE	REMARQUES
2N4-24110-00-X5	RESERVOIR A ESSENCE.	2	MXR
3J1-24240-10	.GRAPHIQUE	1	POUR MXR

5. Veuillez noter que les illustrations sont indiquées à titre de référence pour trouver les numéros de pièces, non pour être utilisées lors de l'assemblage. Lors de l'assemblage, veuillez utiliser le manuel d'entretien adéquat.

6. L'astérisque (\*) placé devant un numéro de référence indique des éléments qui ont été modifiés après la première édition.

## 7. N° de série applicable

N° de Série du moteur

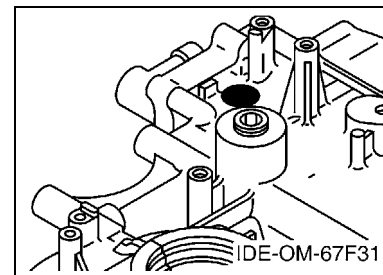
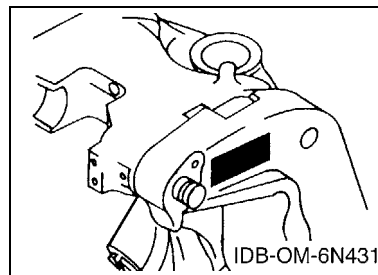

## 8. N° de série initial du moteur applicable

Modèle	N° de série	Modèle	N° de série
F80C	6CK-1000026		

## 9. Code couleur applicable

Abréviation	Nom de la couleur	Code couleur
DBN1	DARK BLUISH GRAY 1	008D

## 10. Informations relatives à la colonne Quantité

N° de la colonne	Nom de la colonne Qté	Modèle applicable
1	6CK2	F80CED

TOP COWLING .....	1
CYLINDER & CRANKCASE 1 .....	2
CRANKSHAFT & PISTON .....	4
CYLINDER & CRANKCASE 2 .....	5
VALVE .....	7
INTAKE 1 .....	10
INTAKE 2 .....	11
INTAKE 3 .....	12
FUEL INJECTION PUMP 1 .....	14
FUEL INJECTION PUMP 2 .....	15
FUEL .....	16
GENERATOR .....	18
ELECTRICAL 1 .....	20
ELECTRICAL 2 .....	22
ELECTRICAL 3 .....	24
ELECTRICAL 4 .....	25
STARTING MOTOR .....	26
BOTTOM COWLING .....	28
CONTROL .....	30
BRACKET 1 .....	32
BRACKET 2 .....	34
BRACKET 3 .....	35
UPPER CASING .....	36
OIL PAN .....	38
LOWER CASING & DRIVE 1 .....	40
LOWER CASING & DRIVE 2 .....	44
FUEL TANK .....	46
STEERING GUIDE .....	47
REPAIR KIT 1 .....	48
REPAIR KIT 2 .....	49
<b>INDEX</b>	
NUMERICAL INDEX .....	51

# TABLE DES MATIERES

CAPOT SUPERIEUR .....	1
CYLINDRE & CARTER 1 .....	2
VILEBREQUIN & PISTON .....	4
CYLINDRE & CARTER 2 .....	5
SOUPAPE .....	7
ADMISSION 1 .....	10
ADMISSION 2 .....	11
ADMISSION 3 .....	12
POMPE A INJECTEUR 1 .....	14
POMPE A INJECTEUR 2 .....	15
CARBURANT .....	16
GENERATRICE .....	18
PARTIE ELECTRIQUE 1 .....	20
PARTIE ELECTRIQUE 2 .....	22
PARTIE ELECTRIQUE 3 .....	24
PARTIE ELECTRIQUE 4 .....	25
DEMARREUR ELECTRIQUE .....	26
CAPOT INFERIEUR .....	28
COMMANDE .....	30
SUPPORT 1 .....	32
SUPPORT 2 .....	34
SUPPORT 3 .....	35
FOURREAU .....	36
VENTILATEUR D'HUILE .....	38
BOITIER D'HELICE TRANSMISSION1 .....	40
BOITIER D'HELICE TRANSMISSION2 .....	44
RESERVOIR A CARBURANT .....	46
FIXATION DE DIRECTION .....	47
KITS DE REPARATION 1 .....	48
KITS DE REPARATION 2 .....	49

## INDEX

INDEX NUMERIQUE .....	51
-----------------------	----

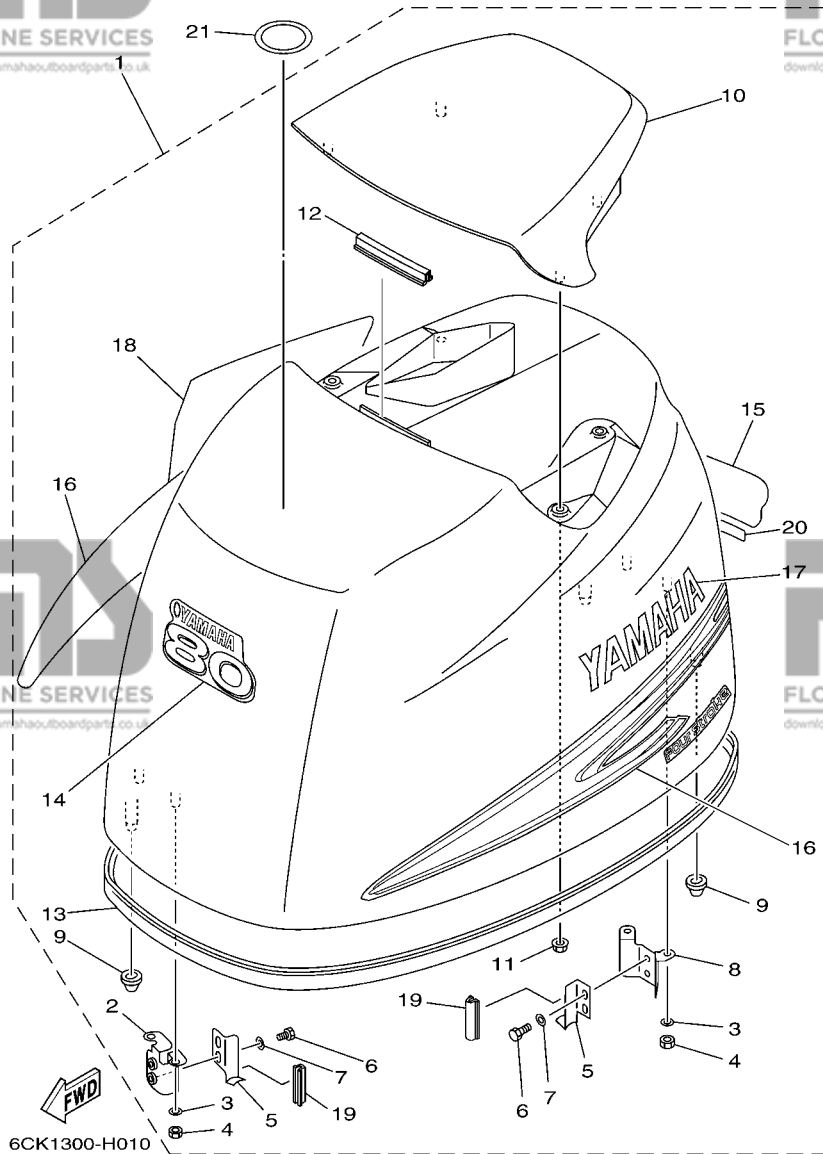

**FIG. 1 TOP COWLING**

**CAPOT SUPERIEUR**

REF. NO.	PART NO. N° PIECES	DESCRIPTION DESCRIPTION	6CK2	REMARKS REMARQUES
1	6CK-42610-00-8D	TOP COWLING ASSY CAPOT (ENS.)	1	
2	67F-42647-00	.HOLDER, CLAMP BAND .SUPPORT, SANDOW DE SERRAGE	1	
3	92990-06100	.WASHER, SPRING .RONDELLE, GROWER	4	
4	95380-06600	.NUT, HEXAGON .ECROU	4	
5	68V-42652-00	.HOOK .CROCHET	2	
6	97095-06012	.BOLT .BOULON	4	
7	92995-06600	.WASHER .RONDELLE	4	
8	67F-42649-00	.HOLDER, CLAMP BAND .SUPPORT, SANDOW DE SERRAGE	1	
9	67F-42662-00	.DAMPER .AMORTISSEUR	3	
10	67F-42613-00-8D	.MOLDING, AIR DUCT .MANCHON A AIR	1	
11	90179-06M24	.NUT .ECROU	4	
12	61N-42628-00	.SEAL .JOINT	1	
13	67F-42615-00	.SEAL .JOINT	1	
14	67G-42677-10	.GRAPHIC, FRONT .ADHESIF, AVANT	1	
15	6D7-42678-00	.GRAPHIC, REAR .ADHESIF, ARRIERE	1	
16	67F-W0070-10	.GRAPHIC SET JEU DIEMBLEMES	1	
17	67F-42681-10	.MARK, COWLING .ADHESIF, CAPOT	1	
18	67F-42682-10	.MARK, COWLING .ADHESIF, CAPOT	1	
19	67F-42628-00	.SEAL .JOINT	2	
20	6BC-42681-00	.MARK, COWLING .ADHESIF, CAPOT	1	
21	67F-13434-10	LABEL, CAUTION ETIQUETTE, ATTENTION	1	

**CYLINDER BLOCK  
ASSY**

- Fig. 2, CYLINDER & CRANKCASE 1  
Ref. No. 2 to 10, 12 to 26,  
28 to 39, 43 to 45
- Fig. 3, CRANKSHAFT & PISTON  
Ref. No. 1 to 10
- Fig. 4, CYLINDER & CRANKCASE 2  
Ref. No. 14
- Fig. 5, VALVE  
Ref. No. 23 to 25
- Fig. 7, INTAKE 2  
Ref. No. 21 to 25
- Fig. 10, FUEL INJECTION PUMP 2  
Ref. No. 7, 17
- Fig. 12, GENERATOR  
Ref. No. 8
- Fig. 13, ELECTRICAL 1  
Ref. No. 14
- Fig. 15, ELECTRICAL 3  
Ref. No. 10 to 12
- Fig. 16, ELECTRICAL 4  
Ref. No. 4 to 7, 11
- Fig. 18, BOTTOM COWLING  
Ref. No. 24
- Fig. 24, OIL PAN  
Ref. No. 30

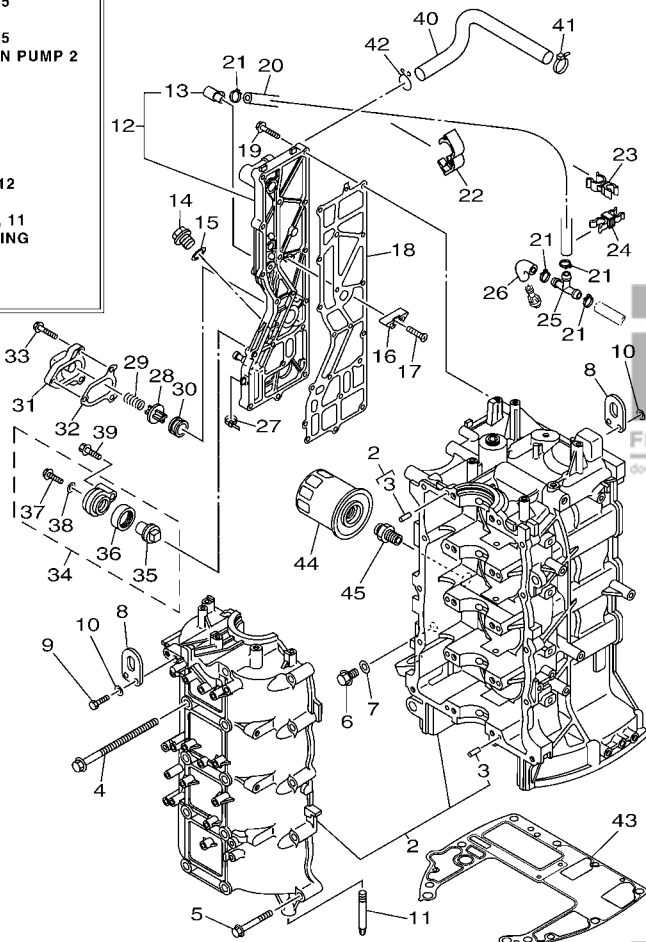

6CK2300-J020

**FIG. 2 CYLINDER & CRANKCASE 1 CYLINDRE & CARTER 1**

REF. NO.	PART NO. N° PIECES	DESCRIPTION DESCRIPTION	6CK2	REMARKS REMARQUES
1	6D8-W009B-04-9S	CYLINDER BLOCK ASSY CYLINDRE GROUPE (ENS.)	1	
2	6D8-15100-01-9S	CRANKCASE ASSY CARTER DE MOTEUR COMPLET	1	
3	93606-12019	.PIN, DOWEL .GOUILLE	10	
4	90119-10M88	BOLT, WITH WASHER BOULON, AVEC RONDELLE	10	
5	90119-08M66	BOLT, WITH WASHER BOULON, AVEC RONDELLE	10	
6	90340-14M06	PLUG, STRAIGHT SCREW PLOT, FILETE DROIT	1	
7	90430-14115	GASKET JOINT	1	
8	62Y-11119-00	HANGER, ENGINE ANNEAU, LEVAGE	2	
9	97095-06020	BOLT BOULON	4	
10	92995-06600	WASHER RONDELLE	4	
11	67F-15142-00	GUIDE 1 GUIDE 1	2	
12	6D8-41113-30-9S	OUTER COVER, EXHAUST COUVERCLE, ECHAPPEMENT	1	
13	676-11372-00	.NIPPLE, HOSE .RACCORD, TUYAU	1	
14	90340-18M09	PLUG, STRAIGHT SCREW PLOT, FILETE DROIT	1	
15	90430-18130	GASKET JOINT	1	
16	6E5-11325-00	ANODE ANODE	3	
17	98780-04016	SCREW, FLAT HEAD VIS A TETE FRAISEE	3	
18	67F-41114-A2	GASKET, EXHAUST OUTER COVER JOINT, COUVERCLE D'ECHAPPEMENT	1	
19	90119-06MA4	BOLT, WITH WASHER BOULON, AVEC RONDELLE	18	
20	6D8-42541-00	PIPE 1 TUYAU 1	1	
21	90465-11M10	CLAMP BRIDE	4	
22	90464-18004	CLAMP BRIDE	1	
23	90464-10010	CLAMP BRIDE	1	
24	90464-11009	CLAMP BRIDE	1	
25	688-24378-00	PIPE, JOINT 3 DURITE RACCORDEMENT 3	1	
26	61A-24316-00	PIPE 6 DURITE 6	1	
27	90465-11M10	CLAMP BRIDE	1	



**FIG. 2 CYLINDER & CRANKCASE 1 CYLINDRE & CARTER 1**

**CYLINDER BLOCK ASSY**

Fig. 2, CYLINDER & CRANKCASE 1  
Ref. No. 2 to 10, 12 to 26,  
28 to 39, 43 to 45

Fig. 3, CRANKSHAFT & PISTON  
Ref. No. 1 to 10

Fig. 4, CYLINDER & CRANKCASE 2  
Ref. No. 14

Fig. 5, VALVE  
Ref. No. 23 to 25

Fig. 7, INTAKE 2  
Ref. No. 21 to 25

Fig. 10, FUEL INJECTION PUMP 2  
Ref. No. 7, 17

Fig. 12, GENERATOR  
Ref. No. 8

Fig. 13, ELECTRICAL 1  
Ref. No. 14

Fig. 15, ELECTRICAL 3  
Ref. No. 10 to 12

Fig. 16, ELECTRICAL 4  
Ref. No. 4 to 7, 11

Fig. 18, BOTTOM COWLING  
Ref. No. 24

Fig. 24, OIL PAN  
Ref. No. 30

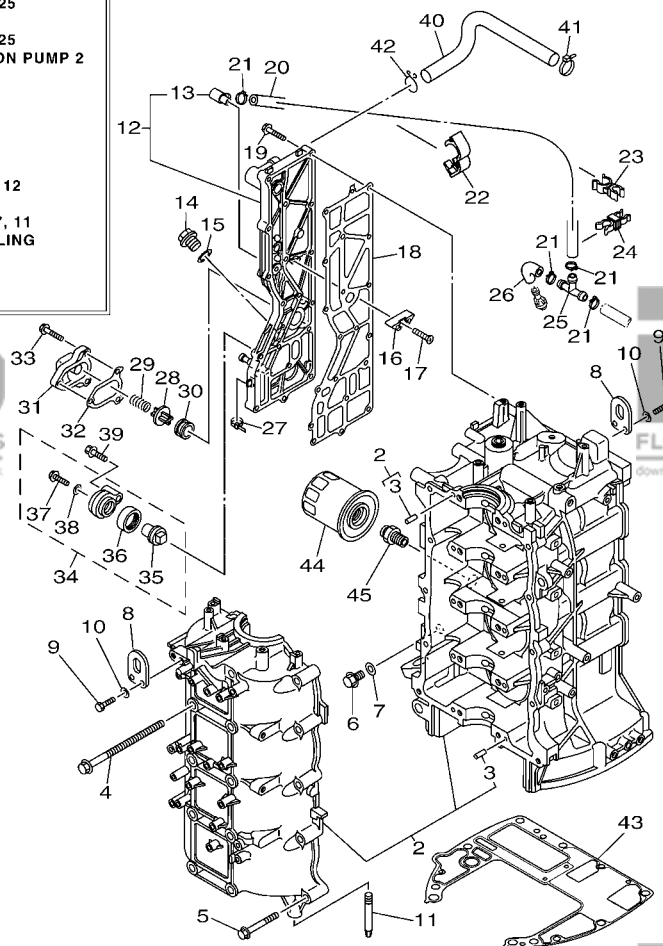

**FWD**

6CK2300-J020

REF. NO.	PART NO. N° PIECES	DESCRIPTION DESCRIPTION	6CK2	REMARKS REMARQUES
28	6G5-12416-00	VALVE, PRESSURE CONTROL SOUPAPE DE CONTROLEUR PRESS	1	
29	90501-16M11	SPRING, COMPRESSION RESSORT, COMPRESSION	1	
30	90480-20M05	GROMMET PASSE-FIL	1	
31	67F-1246A-01-9S	COVER 1 COUVERCLE 1	1	
32	67F-12435-A0	GASKET JOINT	1	
33	90119-06MA2	BOLT, WITH WASHER BOULON, AVEC RONDELLE	3	
34	69J-11301-00	ANODE COVER ASSY COUVERCLE ANODE (ENS.)	1	
35	67F-11325-01	.ANODE .ANODE	1	
36	67F-11328-00	.GROMMET, ANODE .PASSE-FIL	1	
37	90105-06M07	.BOLT, FLANGE .BOULON	1	
38	90430-06M03	.GASKET .JOINT	1	
39	97575-08540	BOLT, WITH WASHER VIS HEXAGONAL AVC RONDELLE	1	
40	67F-1243A-00	HOSE 1 DURITE 1	1	
41	90465-11M10	CLAMP BRIDE	1	
42	90467-20M15	CLIP JONC	1	
43	68V-11351-00	GASKET, CYLINDER JOINT, D'EMBASE	1	
44	5GH-13440-00	ELEMENT ASSY, OIL CLEANER ELEMENT, FILTRE A HUILE	1	
45	90401-20007	BOLT, UNION BOULON, RACCORD	1	

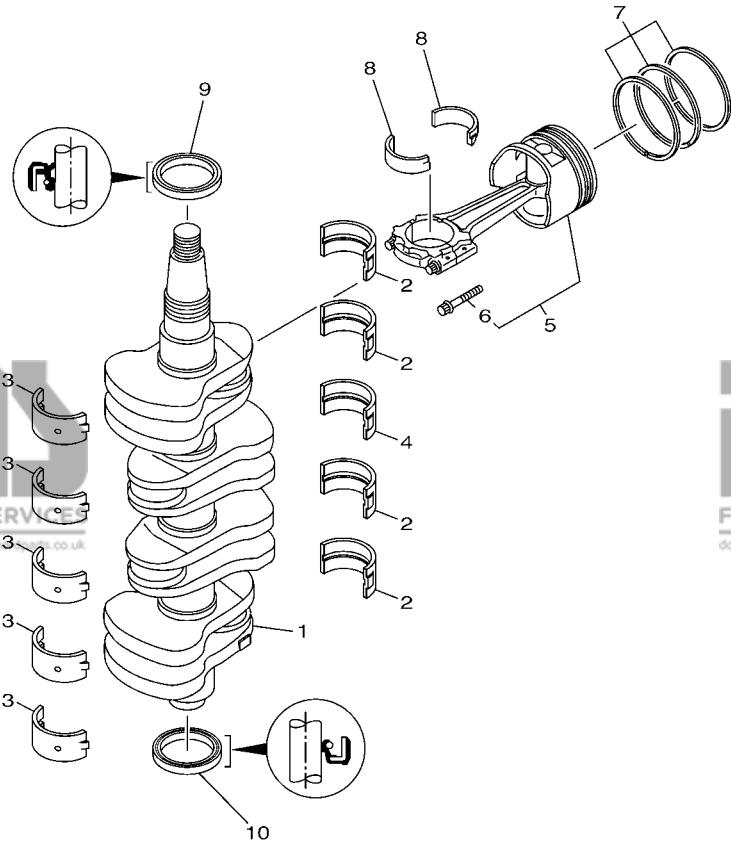

**FWD**  
6D66110-J030

**FIG. 3 CRANKSHAFT & PISTON VILEBREQUIN & PISTON**

REF. NO.	PART NO. N° PIECES	DESCRIPTION DESCRIPTION	6CK2	REMARKS REMARQUES
1	6D8-11411-00	CRANKSHAFT VILEBREQUIN COMPLET	1	
2	67F-11416-00	PLANE BEARING, CRANKSHAFT 1 COUSSINET DE VILEBREQUIN 1	4	UR GREEN UR GREEN
	67F-11416-10	PLANE BEARING, CRANKSHAFT 1 COUSSINET DE VILEBREQUIN 1	4	UR BLUE UR BLUE
	67F-11416-20	PLANE BEARING, CRANKSHAFT 1 COUSSINET DE VILEBREQUIN 1	4	UR RED UR RED
3	67F-11417-00	PLANE BEARING, CRANKSHAFT 2 COUSSINET DE VILEBREQUIN 2	5	UR YELLOW UR YELLOW
	67F-11417-10	PLANE BEARING, CRANKSHAFT 2 COUSSINET DE VILEBREQUIN 2	5	UR GREEN UR GREEN
	67F-11417-20	PLANE BEARING, CRANKSHAFT 2 COUSSINET DE VILEBREQUIN 2	5	UR BLUE UR BLUE
	67F-11417-30	PLANE BEARING, CRANKSHAFT 2 COUSSINET DE VILEBREQUIN 2	5	UR RED UR RED
4	67F-11418-00	PLANE BEARING, CRANKSHAFT 3 COUSSINET DE VILEBREQUIN 3	1	UR GREEN UR GREEN
	67F-11418-10	PLANE BEARING, CRANKSHAFT 3 COUSSINET DE VILEBREQUIN 3	1	UR BLUE UR BLUE
	67F-11418-20	PLANE BEARING, CRANKSHAFT 3 COUSSINET DE VILEBREQUIN 3	1	UR RED UR RED
5	6D8-W1164-21	PISTON/CON-ROD ASSY(STD) PISTON/BIELLE COMPLETE(STD)	4	
	6D8-W1164-31	PISTON/CON-ROD ASSY(0.25MM OS) PISTON/BIELLE COMPLETE:0.25MM	4	AP AP
6	K1C-A3275-00	.BOLT, CONNECTING ROD .BOULON, BIELLE	2	
7	6D8-11603-01	PISTON RING SET (STD) JEU DE SEGMENTS (STD)	4	
	6D8-11604-01	PISTON RING SET (0.25MM O/S) JEU DE SEGMENTS (0.25MM O/S)	4	AP AP
8	6D8-11656-00	PLANE BEARING, CONNECTING ROD ROULEMENT DE BIELLE	8	UR YELLOW UR YELLOW
	6D8-11656-10	PLANE BEARING, CONNECTING ROD ROULEMENT DE BIELLE	8	UR GREEN UR GREEN
	6D8-11656-20	PLANE BEARING, CONNECTING ROD ROULEMENT DE BIELLE	8	UR BLUE UR BLUE
	6D8-11656-30	PLANE BEARING, CONNECTING ROD ROULEMENT DE BIELLE	8	UR RED UR RED
9	93102-48008	OIL SEAL JOINT SPY	1	
10	93101-48001	OIL SEAL JOINT SPY	1	

**CYLINDER HEAD  
ASSY**

Fig. 4, CYLINDER & CRANKCASE 2  
Ref. No. 2 to 14, 23, 28 to 32, 36  
Fig. 2, CYLINDER & CRANKCASE 1  
Ref. No. 43  
Fig. 5, VALVE  
Ref. No. 1 to 13, 26  
Fig. 11, FUEL  
Ref. No. 27

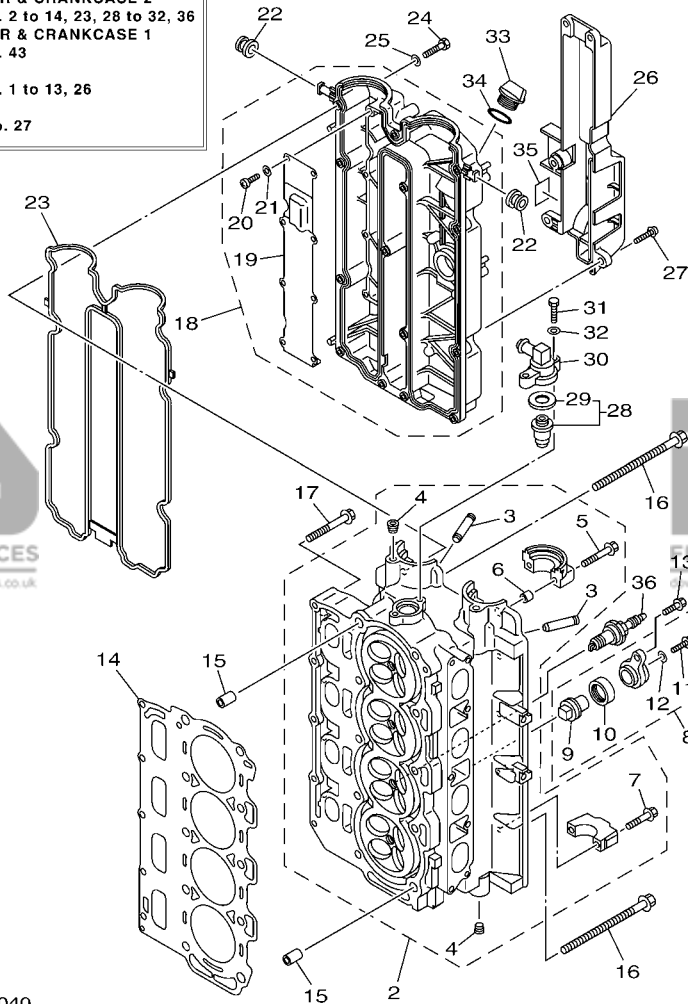

6CK2300-J040

**FIG. 4 CYLINDER & CRANKCASE 2**

**CYLINDRE & CARTER 2**

REF. NO.	PART NO. N° PIECES	DESCRIPTION DESCRIPTION	6CK2	REMARKS REMARQUES
1	6D8-W009A-02-9S	CYLINDER HEAD ASSY CULASSE (ENS.)	1	
2	6D8-11110-01-9S	CYLINDER HEAD ASSY JEU DE CULASSE	1	Go to P/N : PE0-OM-190029
3	67F-11133-10	.GUIDE, VALVE 1 .GUIDE, SOUPAPE 1	16	
4	90344-51019	.PLUG, TAPER SCREW .PLOT, FILETE CONIQUE	4	
5	90119-07235	.BOLT/WASHER-CAM CAPS .BOULON, AVEC RONDELLE	4	
6	91809-08006	.PIN, DOWEL .GOUJON, D'ASSEMBLAGE	4	
7	K0F-A9904-20	.BOLT, WITH WASHER .BOULON, AVEC RONDELLE	16	
8	69J-11301-00	ANODE COVER ASSY COUVERCLE ANODE (ENS.)	2	
9	67F-11325-01	.ANODE .ANODE	1	
10	67F-11328-00	.GROMMET, ANODE .PASSE-FIL	1	
11	90105-06M07	.BOLT, FLANGE .BOULON	1	
12	90430-06M03	.GASKET .JOINT	1	
13	97575-08540	BOLT, WITH WASHER VIS HEXAGONAL AVC RONDELLE	2	
14	67F-11181-03	GASKET, CYLINDER HEAD 1 JOINT, DE CULASSE 1	1	
15	90387-10M08	COLLAR COLLERETTE	2	
16	90105-10M89	BOLT, FLANGE BOULON	10	
17	90119-08M91	BOLT, WITH WASHER BOULON, AVEC RONDELLE	5	
18	6D8-11191-00-9S	COVER, CYLINDER HEAD 1 COUVERCLE, CULASSE 1	1	
19	67F-11168-00	.COVER, BREATHER .COUVERCLE, RENIFLARD	1	
20	98507-04008	.SCREW, PAN HEAD .VIS, TETE TRONCONIQUE	8	
21	92907-04600	.WASHER .RONDELLE	8	
22	90480-12072	GROMMET PASSE-FIL	2	
23	6D8-11356-01	SEAL, CYLINDER 2 JOINT, SPY CYLINDRE	1	
24	97095-06030	BOLT BOULON	14	
25	92995-06600	WASHER RONDELLE	14	
26	67F-11192-01	COVER, CYLINDER HEAD 2 COUVERCLE, CULASSE 2	1	
27	90159-06M29	SCREW, WITH WASHER VIS, AVEC RONDELLE	5	

**CYLINDER HEAD  
ASSY**

Fig. 4, CYLINDER & CRANKCASE 2  
Ref. No. 2 to 14, 23, 28 to 32, 36  
Fig. 2, CYLINDER & CRANKCASE 1  
Ref. No. 43  
Fig. 5, VALVE  
Ref. No. 1 to 13, 26  
Fig. 11, FUEL  
Ref. No. 27

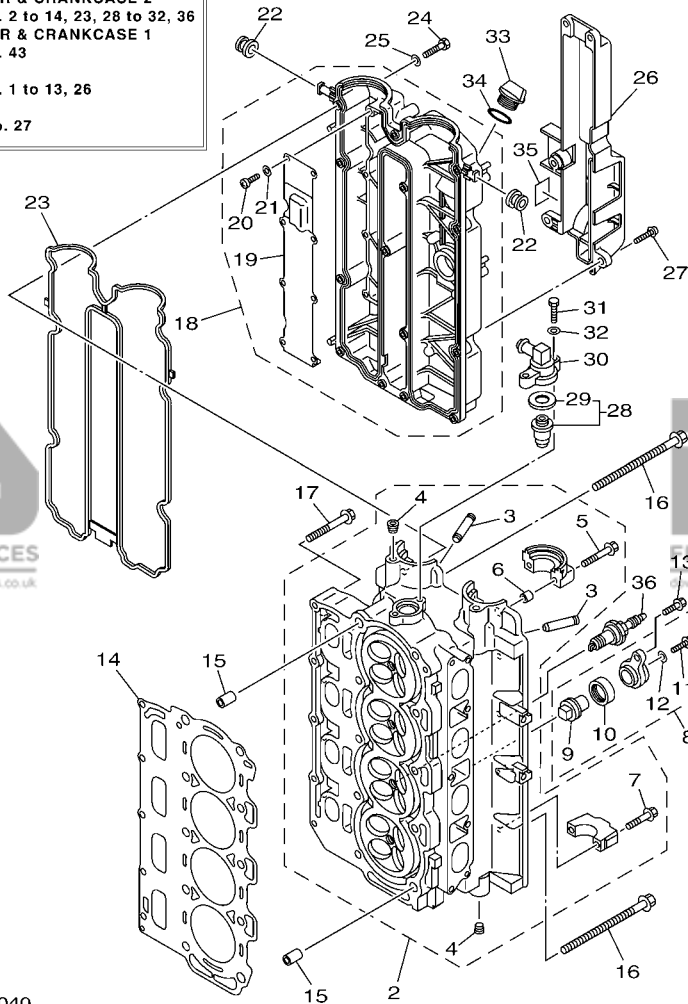

6CK2300-J040

**FIG. 4 CYLINDER & CRANKCASE 2**

**CYLINDRE & CARTER 2**

REF. NO.	PART NO. N° PIECES	DESCRIPTION DESCRIPTION	6CK2	REMARKS REMARQUES
28	67F-12411-01	THERMOSTAT THERMOSTAT	1	
29	67F-12412-00	.SEAL, THERMOSTAT .JOINT, THERMOSTAT	1	
30	68V-12413-00-9S	COVER, THERMOSTAT COUVERCLE, THERMOSTAT	1	
31	97095-06025	BOLT BOULON	2	
32	92995-06600	WASHER RONDELLE	2	
33	6G8-15363-00	PLUG, OIL PLOT, HUILE	1	
34	93210-24M79	O-RING JOINT TORIQUE	1	
35	6D8-83626-00	MARK 6 MARK 6	1	
36	94702-00391	PLUG, SPARK (NGK LFR5A-11) BOUGIE D'ALLUMAGE(NGK LFR5A-11)	4	

News No. PE0-OM-190029(1/4)

Date:2019/08/21

Signature:K.Tanaka

Cause :  Revision Notice  Correction  Sales Unit Change  Others

Model	F75B / F75C / F80B / F80C / F90B / F100D
Subject	PARTS CATALOGUE CORRECTIONS
CATALOGUE NO.	See the "List of Models and CATALOGUE No's below."
Time of YPEC Revision	Text, Illustration --> Sep./20/2019 PDF Replace --> Sep./20/2019 (YPEC = Yamaha Parts Electrical Catalogue = Website parts catalogue)

## FIG.4 CYLINDER & CRANKCASE 2

### 1. LIST CORRECTION

Ref. No.	OLD P/No.	NEW P/No.	DESCRIPTION	Q'TY	REMARKS
2	6D8-11110-00-94 6D8-11110-01-94 6D8-11110-01-9S	<b>6D8-W1110-20-9S</b>	CYLINDER HEAD ASSY	1	<b>*Part revision</b>

**6D8-W1110-20-9S**  
(CYLINDER HEAD ASSY)

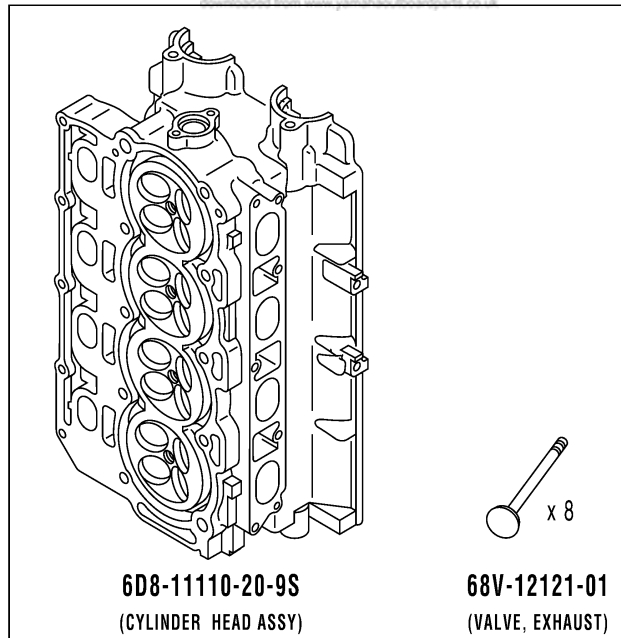

**\*Cylinder head is set compatible with valve**

News No. PE0-OM-190029(2/4)

Date:2019/08/21

Signature:K.Tanaka

Cause :  Revision Notice  Correction  Sales Unit Change  Others

Model	F75B / F75C / F80B / F80C / F90B / F100D
Subject	PARTS CATALOGUE CORRECTIONS
CATALOGUE NO.	See the "List of Models and CATALOGUE No's below."
Time of YPEC Revision	Text, Illustration --> Sep./20/2019 PDF Replace --> Sep./20/2019 (YPEC = Yamaha Parts Electrical Catalogue = Website parts catalogue)

## 2. LIST of Models and CATALOGUE No's.

The applicable MODELS, MODEL CODES, and CATALOGUE No's are as follows.

MODEL NAME	MODEL CODE	MODEL YEAR	CATALOGUE NO.
F75TR,F75BET	6D61	2005	1D6D6-100E1
F80BET	6D71		
F80BET	6D71	2005	1D6D7-300F1
F90TR,F90BET	6D81	2005	1D6D8-100E1
F100DET	6D91	2005	1D6D9-100E1
F100DET	6D91	2005	1D6D9-300F1
F75TR,F75BET	6D62	2006	1E6D6-100E1
F80BET	6D72		
F90TR,F90BET	6D82		
F100DET	6D92		
F90BET	6D82	2006	1E6D8-280E1
F80BET	6D72	2006	1E6D7-300F1
F100DET	6D92		
F75TR(F)	6D63	2007	1F6D6-100E1
F80BET	6D73		
F90TR(F)	6D83		
F100DET	6D93		
F75BET	6D63	2007	1F6D6-200S1
F80BET	6D73		
F90BET	6D83		
F100DET	6D93		
F80BET	6D73	2007	1F6D7-300F1
F100DET	6D93		
F75TR(G)	6D64	2008	1G6D6-100E1
F80BET	6D74		
F90TR(G)	6D84		
F100DET	6D94		
F75BET	6D64	2008	1G6D6-200S1 1G6D6-415M1
F80BET	6D74		
F90BET	6D84		
F100DET	6D94		

News No. PE0-OM-190029(3/4)

Date:2019/08/21

Signature:K.Tanaka

Cause :  Revision Notice  Correction  Sales Unit Change  Others

Model	F75B / F75C / F80B / F80C / F90B / F100D
Subject	PARTS CATALOGUE CORRECTIONS
CATALOGUE NO.	See the "List of Models and CATALOGUE No's below."
Time of YPEC Revision	Text, Illustration --> Sep./20/2019
	PDF Replace --> Sep./20/2019
(YPEC = Yamaha Parts Electrical Catalogue = Website parts catalogue)	

## 2. LIST of Models and CATALOGUE No's.

The applicable MODELS, MODEL CODES, and CATALOGUE No's are as follows.

MODEL NAME	MODEL CODE	MODEL YEAR	CATALOGUE NO.
F80BET F100DET	6D74 6D94	2008	1G6D7-300F1
F75TRH F80BET F90TRH F100DET	6D65 6D75 6D85 6D95	2009	1H6D6-100E1
F75TR F90TR	6D65 6D85	2009	1H6D6-110E1
F75BET F80BET F90BET F100DET	6D65 6D75 6D85 6D95	2009	1H6D6-200S1 1H6D6-415M1
F80BET F100DET	6D75 6D95	2009	1H6D7-300F1
F75 F80BET F90 F100DET	6D66 6D76 6D86 6D96	2010	1J6D6-100E1
F75TR F90TR	6D66 6D86	2010	1J6D6-110E1 1J6D8-110E1
F75BET F80BET F90BET F100DET	6D66 6D76 6D86 6D96	2010	1J6D6-200S1 1J6D6-415M1
F80BET F100DET	6D76 6D96	2010	1J6D7-300F1
F80BET F100DET	6D76 6D96	2010	1J6D7-370E1

News No. PE0-OM-190029(4/4)

Date:2019/08/21

Signature:K.Tanaka

Cause :  Revision Notice  Correction  Sales Unit Change  Others

Model	F75B / F75C / F80B / F80C / F90B / F100D
Subject	PARTS CATALOGUE CORRECTIONS
CATALOGUE NO.	See the "List of Models and CATALOGUE No's below."
Time of YPEC Revision	Text, Illustration --> Sep./20/2019 PDF Replace --> Sep./20/2019 (YPEC = Yamaha Parts Electrical Catalogue = Website parts catalogue)

## 2. LIST of Models and CATALOGUE No's.

The applicable MODELS, MODEL CODES, and CATALOGUE No's are as follows.

MODEL NAME	MODEL CODE	MODEL YEAR	CATALOGUE NO.
F75CED,EHD	6BC1	2007	1F6BC-200S1
F75CED,EHD	6BC2	2008	1G6BC-200S1
F75CED,EHD	6BC3	2009	1H6BC-200S1
F75CED,EHD	6BC4	2010	1J6BC-200S1
F80CED	6CK1	2009	1H6CK-300F1
F80CED	6CK2	2010	1J6CK-300F1

Thank you very much for your cooperation.



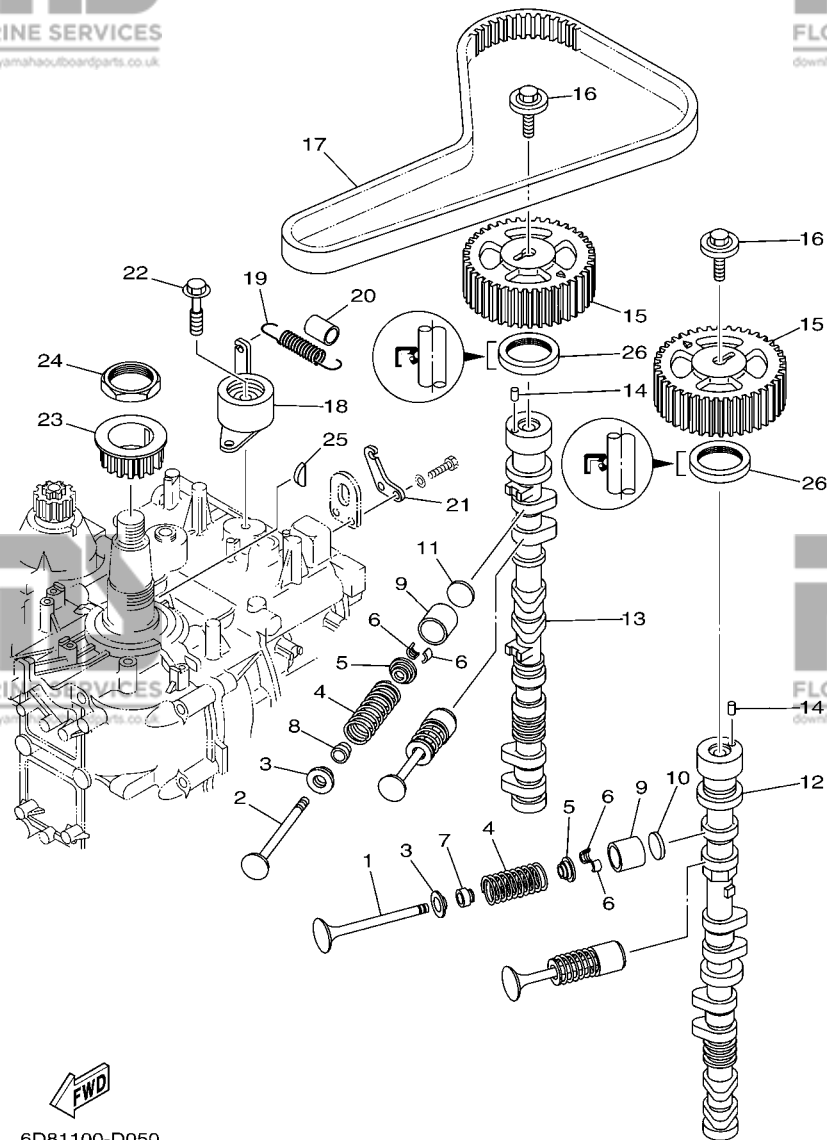

6D81100-D050

**FIG. 5 VALVE**

**SOUPAPE**

REF. NO.	PART NO. N° PIECES	DESCRIPTION DESCRIPTION	60K2	REMARKS REMARQUES
1	68V-12111-00	VALVE, INTAKE SOUPAPE, ADMISSION	8	
2	68V-12121-00	VALVE, EXHAUST SOUPAPE, ECHAPPEMENT	8	
3	67F-12116-00	SEAT, VALVE SPRING SIEGE, RESSORT DE SOUPAPE	16	
4	67F-12114-00	SPRING, VALVE OUTER RESSORT DE SOUPAPE, EXTERNE	16	
5	67F-12117-00	RETAINER, VALVE SPRING BUTEE DE RESSORT DE SOUPAPE	16	
6	67F-12118-00	COTTER, VALVE FRAISE, SOUPAPE	32	
7	K0A-A3721-00	SEAL, VALVE STEM JOINT, QUEUE DE SOUPAPE	8	
8	K0A-A3722-00	SEAL, VALVE STEM 2 JOINT, QUEUE DE SOUPAPE 2	8	
9	67F-12153-00	LIFTER, VALVE LEVE-SOUPAPE	16	
10	67F-12168-00	PAD, ADJUSTING (2.000) PASTILLE, DE REGLAGE (2.000)	16	UR
	67F-12168-10	PAD, ADJUSTING (2.025) PASTILLE, DE REGLAGE (2.025)	16	UR
	67F-12168-20	PAD, ADJUSTING (2.050) PASTILLE, DE REGLAGE (2.050)	16	UR
	67F-12168-30	PAD, ADJUSTING (2.075) PASTILLE, DE REGLAGE (2.075)	16	UR
	67F-12168-40	PAD, ADJUSTING (2.100) PASTILLE, DE REGLAGE (2.100)	16	UR
	67F-12168-50	PAD, ADJUSTING (2.125) PASTILLE, DE REGLAGE (2.125)	16	UR
	67F-12168-60	PAD, ADJUSTING (2.150) PASTILLE, DE REGLAGE (2.150)	16	UR
	67F-12168-70	PAD, ADJUSTING (2.175) PASTILLE, DE REGLAGE (2.175)	16	UR
	67F-12168-80	PAD, ADJUSTING (2.200) PASTILLE, DE REGLAGE (2.200)	16	UR
	67F-12168-A0	PAD, ADJUSTING (2.225) PASTILLE, DE REGLAGE (2.225)	16	UR
	67F-12168-B0	PAD, ADJUSTING (2.250) PASTILLE, DE REGLAGE (2.250)	16	UR
	67F-12168-C0	PAD, ADJUSTING (2.275) PASTILLE, DE REGLAGE (2.275)	16	UR
	67F-12168-D0	PAD, ADJUSTING (2.300) PASTILLE, DE REGLAGE (2.300)	16	UR
	67F-12168-E0	PAD, ADJUSTING (2.325) PASTILLE, DE REGLAGE (2.325)	16	UR
	67F-12168-F0	PAD, ADJUSTING (2.350) PASTILLE, DE REGLAGE (2.350)	16	UR
	67F-12168-G0	PAD, ADJUSTING (2.375) PASTILLE, DE REGLAGE (2.375)	16	UR
	67F-12168-H0	PAD, ADJUSTING (2.400) PASTILLE, DE REGLAGE (2.400)	16	UR
	67F-12168-J0	PAD, ADJUSTING (2.425) PASTILLE, DE REGLAGE (2.425)	16	UR

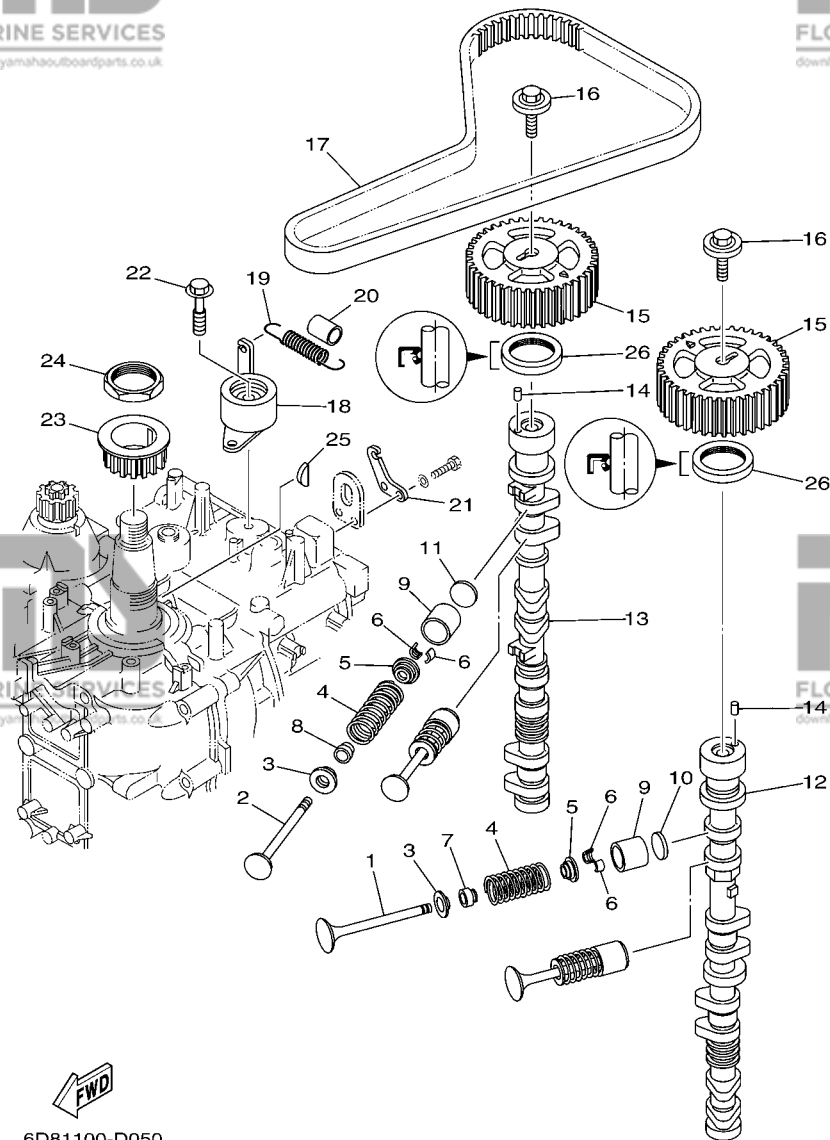

**FWD**  
6D81100-D050

**FIG. 5 VALVE**

**SOUPAPE**

REF. NO.	PART NO. N° PIECES	DESCRIPTION DESCRIPTION	60K2	REMARKS REMARQUES
10	67F-12168-K0	PAD, ADJUSTING (2.450) PASTILLE, DE REGLAGE (2.450)	16	UR
	67F-12168-L0	PAD, ADJUSTING (2.475) PASTILLE, DE REGLAGE (2.475)	16	UR
	67F-12168-M0	PAD, ADJUSTING (2.500) PASTILLE, DE REGLAGE (2.500)	16	UR
	67F-12168-N0	PAD, ADJUSTING (2.525) PASTILLE, DE REGLAGE (2.525)	16	UR
	67F-12168-P0	PAD, ADJUSTING (2.550) PASTILLE, DE REGLAGE (2.550)	16	UR
	67F-12168-R0	PAD, ADJUSTING (2.575) PASTILLE, DE REGLAGE (2.575)	16	UR
	67F-12168-S0	PAD, ADJUSTING (2.600) PASTILLE, DE REGLAGE (2.600)	16	UR
	67F-12168-T0	PAD, ADJUSTING (2.625) PASTILLE, DE REGLAGE (2.625)	16	UR
	67F-12168-U0	PAD, ADJUSTING (2.650) PASTILLE, DE REGLAGE (2.650)	16	UR
	67F-12168-V0	PAD, ADJUSTING (2.675) PASTILLE, DE REGLAGE (2.675)	16	UR
	67F-12168-W0	PAD, ADJUSTING (2.700) PASTILLE, DE REGLAGE (2.700)	16	UR
	67F-12168-X0	PAD, ADJUSTING (2.725) PASTILLE, DE REGLAGE (2.725)	16	UR
	67F-12168-Y0	PAD, ADJUSTING (2.750) PASTILLE, DE REGLAGE (2.750)	16	UR
11	67F-12169-00	PAD, ADJUSTING (2.775) PASTILLE, DE REGLAGE (2.775)	16	UR
	67F-12169-10	PAD, ADJUSTING (2.800) PASTILLE, DE REGLAGE (2.800)	16	UR
	67F-12169-20	PAD, ADJUSTING (2.825) PASTILLE, DE REGLAGE (2.825)	16	UR
	67F-12169-30	PAD, ADJUSTING (2.850) PASTILLE, DE REGLAGE (2.850)	16	UR
	67F-12169-40	PAD, ADJUSTING (2.875) PASTILLE, DE REGLAGE (2.875)	16	UR
	67F-12169-50	PAD, ADJUSTING (2.900) PASTILLE, DE REGLAGE (2.900)	16	UR
	67F-12169-60	PAD, ADJUSTING (2.925) PASTILLE, DE REGLAGE (2.925)	16	UR
	67F-12169-70	PAD, ADJUSTING (2.950) PASTILLE, DE REGLAGE (2.950)	16	UR
	67F-12169-80	PAD, ADJUSTING (2.975) PASTILLE, DE REGLAGE (2.975)	16	UR
	67F-12169-A0	PAD, ADJUSTING (3.000) PASTILLE, DE REGLAGE (3.000)	16	UR
	67F-12169-B0	PAD, ADJUSTING (3.025) PASTILLE, DE REGLAGE (3.025)	16	UR
	67F-12169-C0	PAD, ADJUSTING (3.050) PASTILLE, DE REGLAGE (3.050)	16	UR
	67F-12169-D0	PAD, ADJUSTING (3.075) PASTILLE, DE REGLAGE (3.075)	16	UR
	67F-12169-E0	PAD, ADJUSTING (3.100) PASTILLE, DE REGLAGE (3.100)	16	UR

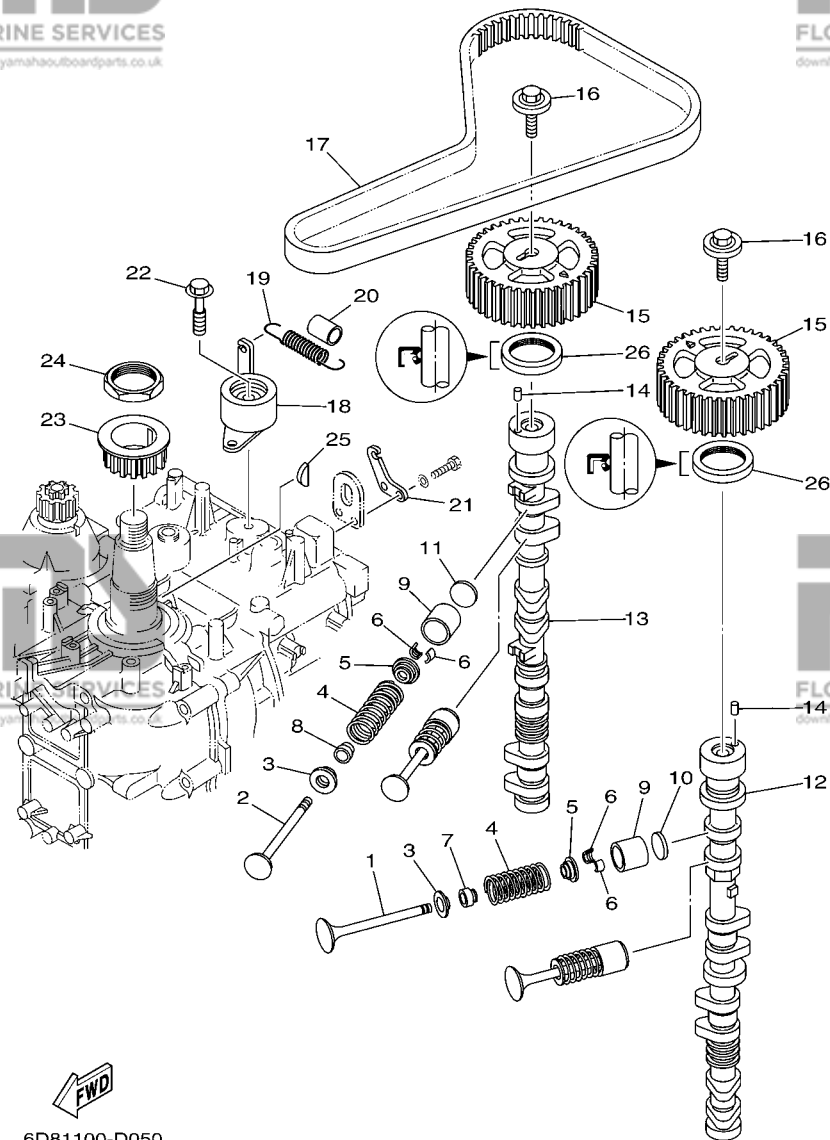

6D81100-D050

**FIG. 5 VALVE**

**SOUPAPE**

REF. NO.	PART NO. N° PIECES	DESCRIPTION DESCRIPTION	60K2	REMARKS REMARQUES
11	67F-12169-F0	PAD, ADJUSTING (3.125) PASTILLE, DE REGLAGE (3.125)	16	UR
	67F-12169-G0	PAD, ADJUSTING (3.150) PASTILLE, DE REGLAGE (3.150)	16	UR
	67F-12169-H0	PAD, ADJUSTING (3.175) PASTILLE, DE REGLAGE (3.175)	16	UR
	67F-12169-J0	PAD, ADJUSTING (3.200) PASTILLE, DE REGLAGE (3.200)	16	UR
	67F-12169-K0	PAD, ADJUSTING (3.225) PASTILLE, DE REGLAGE (3.225)	16	UR
	67F-12169-L0	PAD, ADJUSTING (3.250) PASTILLE, DE REGLAGE (3.250)	16	UR
	67F-12169-M0	PAD, ADJUSTING (3.275) PASTILLE, DE REGLAGE (3.275)	16	UR
	67F-12169-N0	PAD, ADJUSTING (3.300) PASTILLE, DE REGLAGE (3.300)	16	UR
12	6D8-12171-00	CAMSHAFT 1 ARBRE A CAMES 1	1	
13	67F-12181-00	CAMSHAFT 2 ARBRE A CAMES 2	1	
14	93605-10108	PIN, DOWEL AXE	2	
15	67F-11537-00	GEAR, DRIVEN PIGNON SECONDAIRE	2	
16	68V-12157-00	BOLT BOULON	2	
17	67F-46241-00	BELT COURROIE TRAPEZOIDALE	1	
18	67F-11590-00	TENSIONER ASSY TENDEUR (ENS.)	1	
19	90506-16M39	SPRING, TENSION RESSORT, TENSION	1	
20	90445-15M03	HOSE (L23) DURITE (L23)	1	
21	67F-11595-00	PLATE, VALVE PLAQUE DE SOUPAPE	1	
22	90119-10M72	BOLT, WITH WASHER BOULON, AVEC RONDELLE	1	
23	6D8-11536-00	GEAR, DRIVE ENGRENAGE, MENANT	1	
24	90170-40008	NUT ECROU	1	
25	90280-04008	KEY, WOODRUFF CLAVETTE, DEMI-LUNE	1	
26	93102-38008	OIL SEAL JOINT SPY	2	

FIG. 6 INTAKE 1

ADMISSION 1

REF. NO.	PART NO. N° PIECES	DESCRIPTION DESCRIPTION	6CK2	REMARKS REMARQUES
1	6D8-14200-00	INTAKE ASSY ADMISSION (ENS.)	1	
2	6D8-13641-00	..MANIFOLD 1 ..TUBULURE 1	1	
3	6D8-13645-00	..GASKET, MANIFOLD 1 ..JOINT, TUBULURE 1	1	
4	6D8-13557-00	..GASKET ..JOINT	1	
5	6D8-13750-00	..THROTTLE BODY ASSY ..CARTER D'ACCELERATEUR COMPLET	1	
6	6C5-85885-00	..THROTTLE SENSOR ASSY ..SENSITOMETRE (ENS.)	1	
7	6C5-81145-00	..SCREW 1 ..VIS 1	2	
8	6C5-8182L-00	..O-RING 1 ..JOINT TORIQUE 1	1	
9	6C5-14496-00	..BOLT ..BOULON	3	
10	6D8-13105-01	..CONTROL VALVE ASSY ..SOUPAPE DE CONTROLE COMPLET	1	
11	6C5-1319C-00	..O-RING ..JOINT TORIQUE	1	
12	6C5-81146-00	..SCREW 2 ..VIS 2	4	
13	6D8-13161-00	..PIPE, DELIVERY 1 ..DURITE REFOULEMENT 1	1	
14	6C5-14446-00	..BOLT ..BOULON	2	
15	6D8-13761-00	..INJECTOR ..INJECTEUR	4	
16	6C5-1410B-00	..PACKING KIT ..POCHETTE DE JOINTS	1	
17	68F-83688-00	..SENSOR ASSY ..SONDE (ENS.)	1	
18	90464-18246	..CLAMP ..BRIDE	1	

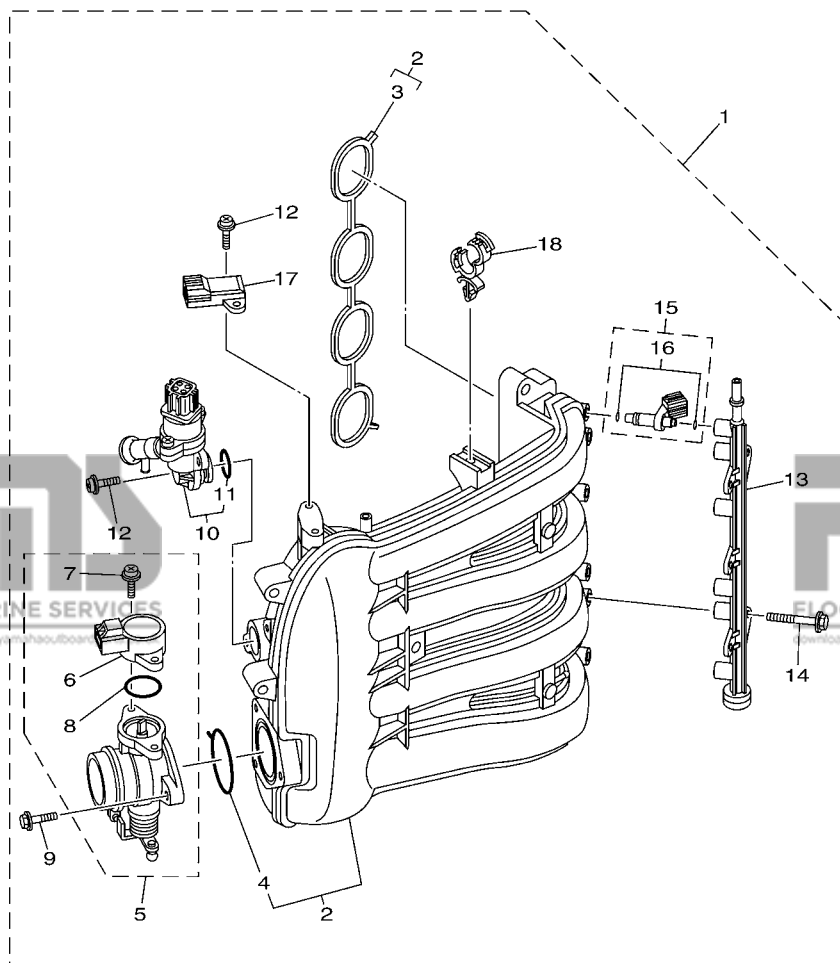

**FWD**  
6D81100-D060

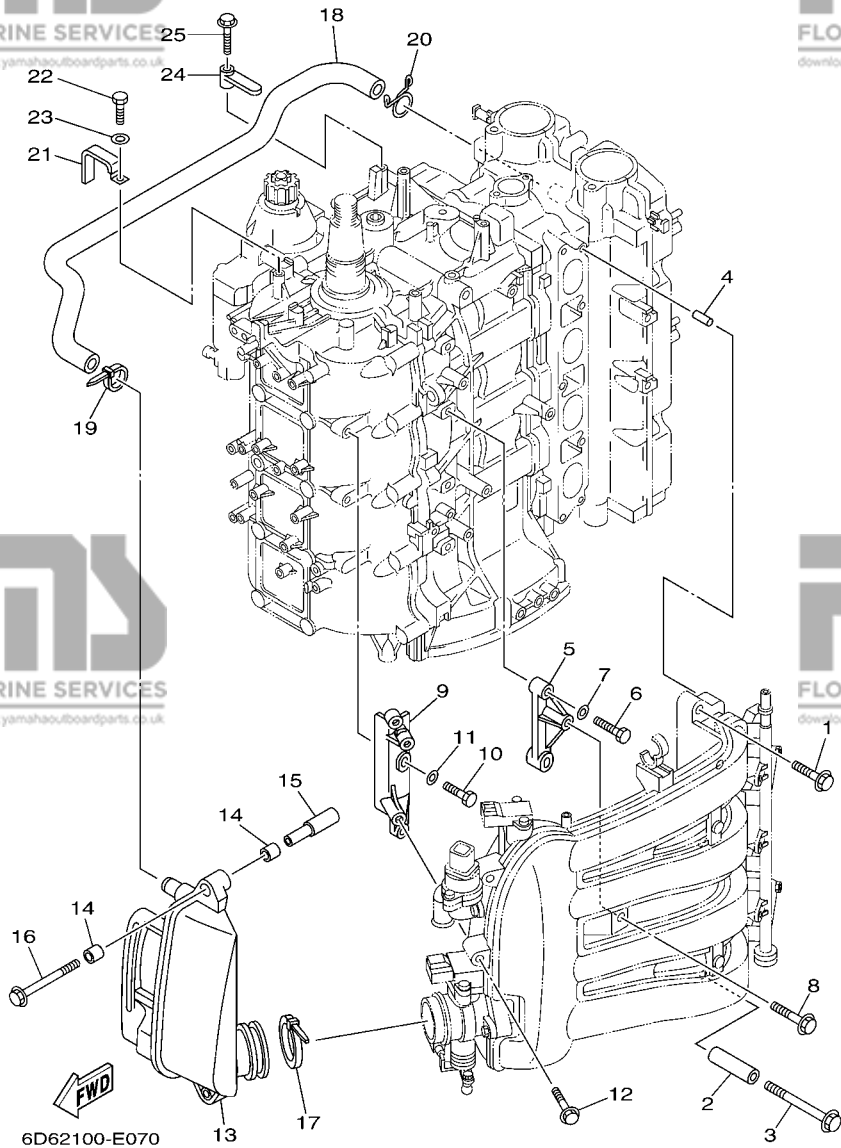
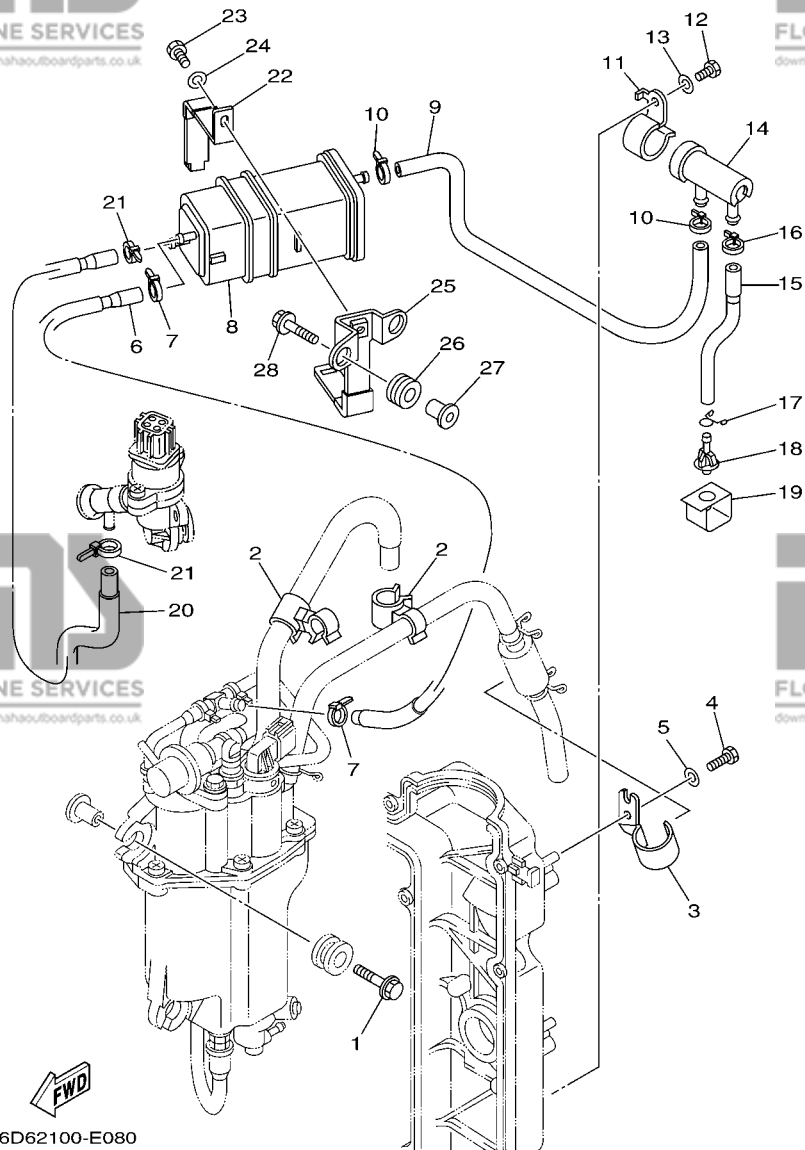

FIG. 7 INTAKE 2

ADMISSION 2

REF. NO.	PART NO. N° PIECES	DESCRIPTION DESCRIPTION	60K2	REMARKS REMARQUES
1	90119-08069	BOLT, WITH WASHER BOULON, AVEC RONDELLE	4	
2	90387-08033	COLLAR COLLERETTE	1	
3	90119-08M03	BOLT, WITH WASHER BOULON, AVEC RONDELLE	1	
4	91690-50014	PIN, SPRING AGRAFFE	2	
5	6D8-14291-00-94	BRACKET 1 SUPPORT 1	1	
6	97095-06030	BOLT BOULON	2	
7	92995-06600	WASHER RONDELLE	2	
8	90119-06087	BOLT, WITH WASHER BOULON, AVEC RONDELLE	1	
9	6D8-14292-00-94	BRACKET 2 SUPPORT 2	1	
10	97095-06020	BOLT BOULON	2	
11	92995-06600	WASHER RONDELLE	2	
12	90119-06087	BOLT, WITH WASHER BOULON, AVEC RONDELLE	2	
13	6D6-14440-00	SILENCER ASSY, INTAKE SIENCIEUX D'ADMISSION	1	
14	90386-08001	BUSH DOUILLE	4	
15	90387-07013	COLLAR COLLERETTE	2	
16	90119-06113	BOLT, WITH WASHER BOULON, AVEC RONDELLE	2	
17	90464-76001	CLAMP BRIDE	1	
18	6D8-15373-00	PIPE, BREATHER DURITE DE RENIFLARD	1	
19	90465-11M59	CLAMP BRIDE	1	
20	90467-20M15	CLIP JONC	1	
21	90465-12M03	CLAMP BRIDE	1	
22	97095-06012	BOLT BOULON	1	
23	92995-06600	WASHER RONDELLE	1	
24	6D8-82544-00	CLAMP COLLIER	1	
25	95895-06025	BOLT, FLANGE BOULON	1	



**FIG. 8 INTAKE 3**

**ADMISSION 3**

REF. NO.	PART NO. N° PIECES	DESCRIPTION DESCRIPTION	60K2	REMARKS REMARQUES
1	90119-06M08	BOLT, WITH WASHER BOULON, AVEC RONDELLE	3	
2	90464-15007	CLAMP BRIDE	2	
3	6D8-13428-00	BRACKET, STRAINER 1 SUPPORT, FILTRE 1	1	
4	97095-06012	BOLT BOULON	1	
5	92995-06600	WASHER RONDELLE	1	
6	6D8-24314-01	PIPE 4 DURITE 4	1	
7	90465-11M10	CLAMP BRIDE	2	
8	69J-24170-00	CANISTER ASSY BANDE, RASERVOIR A ESSENCE	1	
9	6D8-24315-00	PIPE 5 DURITE 5	1	
10	90465-11M10	CLAMP BRIDE	2	
11	6D8-2417H-00	CLAMP 1 COLLIER 1	1	
12	97095-06010	BOLT BOULON	1	
13	92995-06600	WASHER RONDELLE	1	
14	69J-24502-00	FILTER, FUEL FILTRE	1	
15	6D8-24316-00	PIPE 6 DURITE 6	1	
16	90465-11M10	CLAMP BRIDE	1	
17	90467-09M03	CLIP JONC	1	
18	69J-44391-00	NIPPLE, HOSE RACCORD D'ESSENCE	1	
19	6D8-2413X-00	PLATE PLAQUE	1	
20	6D8-24317-01	PIPE 7 DURITE 7	1	
21	90465-11M10	CLAMP BRIDE	2	
22	69J-2419A-00	HOLDER SUPPORT	1	
23	97095-06016	BOLT BOULON	1	
24	92995-06600	WASHER RONDELLE	1	
25	6D8-2134X-00	BRACKET, CANISTER SUPPORT	1	
26	90480-10M23	GROMMÉT PASSE-FIL	2	
27	90387-06M60	COLLAR COLLERETTE	2	

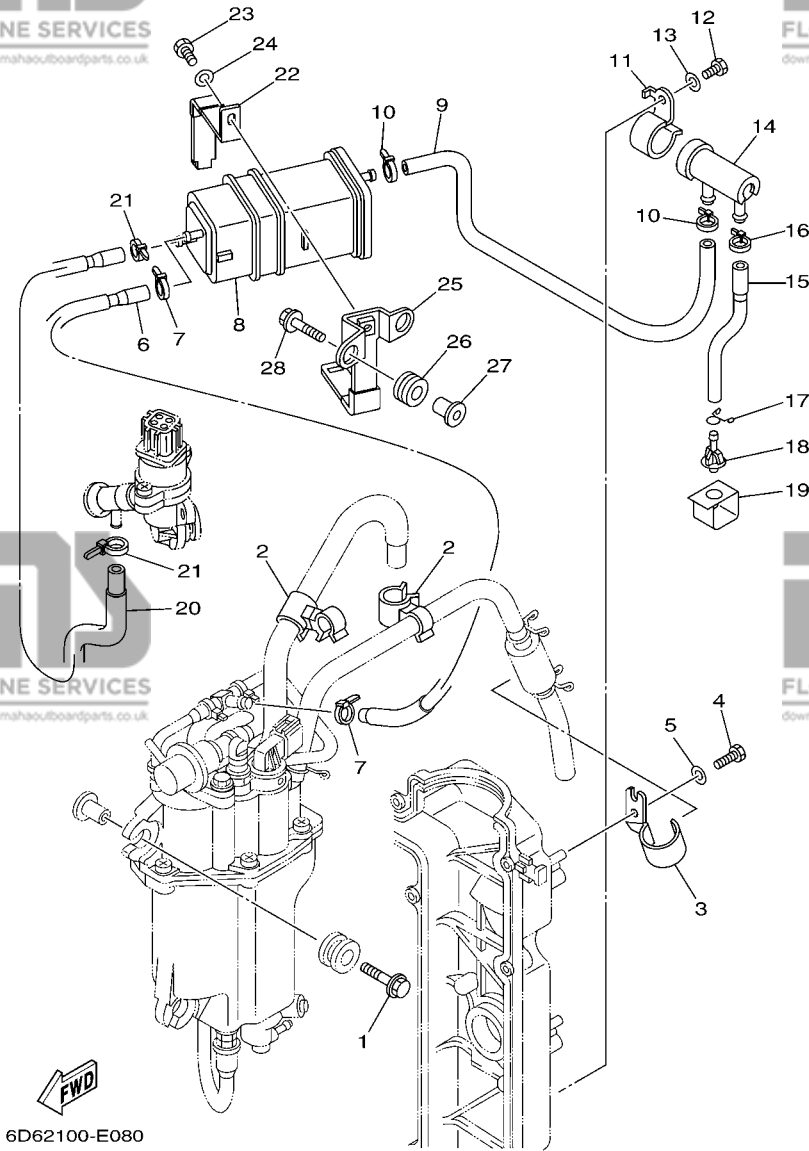

**FIG. 8 INTAKE 3**

**ADMISSION 3**

REF. NO.	PART NO. N° PIECES	DESCRIPTION DESCRIPTION	QTY	REMARKS REMARQUES
28	90119-06M59	BOLT, WITH WASHER BOULON, AVEC RONDELLE	2	

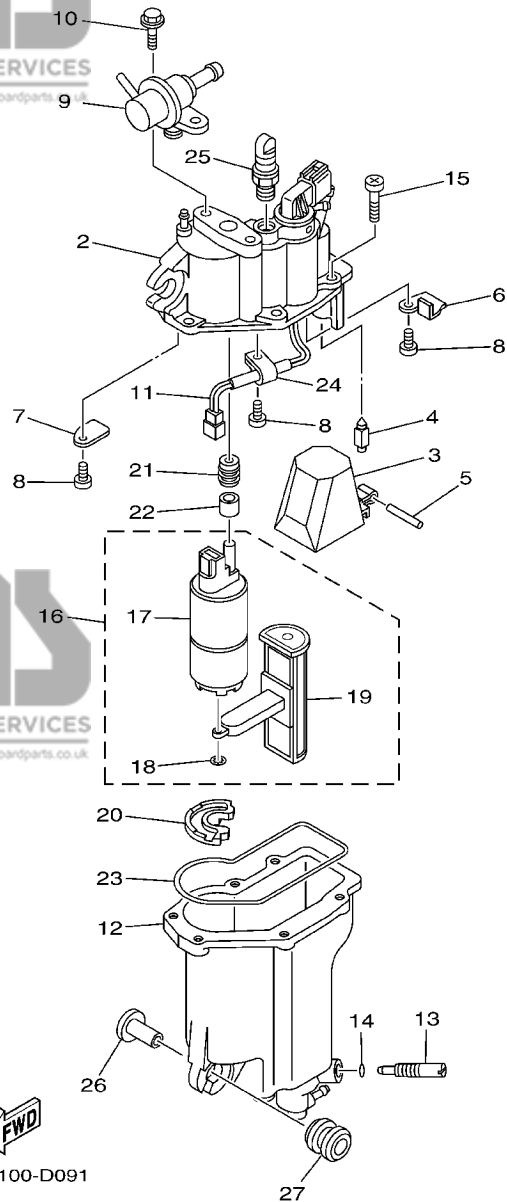

6D81100-D091

**FLOAT CHAMBER ASSY**  
(Fig. 9, Ref. No. 2 to 27  
Fig. 10, Ref. No. 1 to 22)

**FIG. 9 FUEL INJECTION PUMP 1**

**POMPE A INJECTEUR 1**

REF. NO.	PART NO. N° PIECES	DESCRIPTION DESCRIPTION	6CK2	REMARKS REMARQUES
1	6D8-14180-20	FLOAT CHAMBER ASSY CUVE DE FLOTTEUR	1	
2	6D8-14182-00	COVER, FLOAT CHAMBER COUVERCLE, CUVE DE FLOTTEUR	1	
3	6C5-14985-00	FLOAT FLOTTEUR	1	
4	6C5-14546-00	VALVE, NEEDLE POINTEAU	1	
5	6C5-14386-00	PIN, FLOAT AXE, FLOTTEUR	1	
6	6C5-2441R-00	PLATE, BAFFLE 1 SEPARATEUR 1	1	
7	6C5-2441T-00	PLATE, BAFFLE 2 SEPARATEUR 2	1	
8	6C5-24453-00	SCREW VIS	3	
9	6C5-13906-01	REGULATOR, PRESSURE REGULATEUR DE PRESSION	1	
10	6C5-24592-00	BOLT BOLTE	2	
11	6C5-87226-00	WIRE HARNESS ASSY ENS. FAISCEAU ELECTRIQUE	1	
12	6D8-14960-00	BODY ASSY CARTER (ENS.)	1	
13	6C5-14191-00	PLUG, DRAIN PLOT, VIDANGE	1	
14	6C5-14397-00	O-RING JOINT TORIQUE	1	
15	6C5-14567-00	SCREW VIS	6	
16	6C5-13910-00	FUEL PUMP ASSY POMPE A ESSENCE COMPLET	1	
17	6C5-13907-00	.FUEL PUMP COMP. .POMPE A CARBURANT COMP.	1	
18	6C5-14127-00	.CLIP .JONC	1	
19	6C5-13915-00	.FILTER .FILTRE	1	
20	6C5-13593-00	DAMPER AMORTISSEUR	1	
21	6C5-13781-00	DAMPÉR, PUMP AMORTISSEUR, POMPE	1	
22	6C5-13716-00	COLLAR COLLERETTE	1	
23	6C5-14984-00	GASKET, FLOAT CHAMBER JOINT, CUVE DE FLOTTEUR	1	
24	6C5-21337-00	CLAMP, CABLE COLLIER, CABLE	1	
25	6C5-14225-00	CAP COUVERCLE	1	
26	90387-06M69	COLLAR COLLERETTE	3	
27	90480-09M12	GROMMET PASSE-FIL	3	



**FIG. 10 FUEL INJECTION PUMP 2**

**POMPE A INJECTEUR 2**

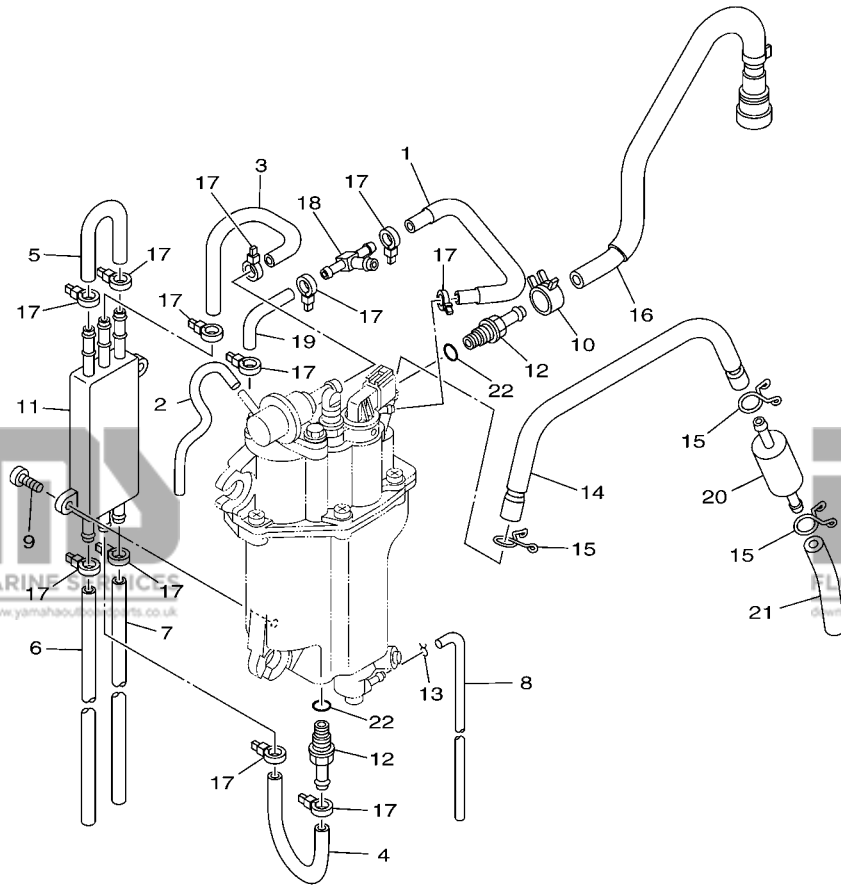

6D66110-J100

REF. NO.	PART NO. N° PIECES	DESCRIPTION DESCRIPTION	6CK2	REMARKS REMARQUES
1	6D8-13546-01	HOSE 2 DURITE 2	1	
2	6D8-13542-01	HOSE, VACUUM SENSING 1 DURITE 1	1	
3	6C5-24321-00	PIPE 10 DURITE 10	1	
4	6C5-24322-00	PIPE 11 DURITE 11	1	
5	6C5-24323-00	PIPE 12 DURITE 12	1	
6	6D8-24324-01	PIPE 13 DURITE 13	1	
7	6D8-24325-10	PIPE 14 DURITE 14	1	
8	6C5-14149-00	PIPE (L200) DURITE (L200)	1	
9	6C5-24444-00	SCREW VIS	2	
10	6C5-13577-00	CLIP AGRAFE	1	
11	6C5-21841-00	COOLER RADIATEUR	1	
12	6C5-14251-00	NIPPLE RACCORD	2	
13	6C5-2411M-00	CLIP JONC	1	
14	6D8-14148-00	PIPE DURITE	1	
15	6C5-24387-00	CLIP SANDOW	3	
16	6D8-13974-00	PIPE, FUEL 4 TUBE 4, CARBURANT	1	
17	90465-11M10	CLAMP BRIDE	12	
18	6C5-24379-00	PIPE, JOINT 4 DURITE RACCORDEMENT 4	1	
19	6C5-13545-00	HOSE 1 DURITE 1	1	
20	6C5-24251-00	STRAINER 1 FILTRE 1	1	
21	6D8-2451B-00	HOSE, FUEL INLET DURITE	1	
22	6C5-13739-00	O-RING JOINT TORIQUE	2	

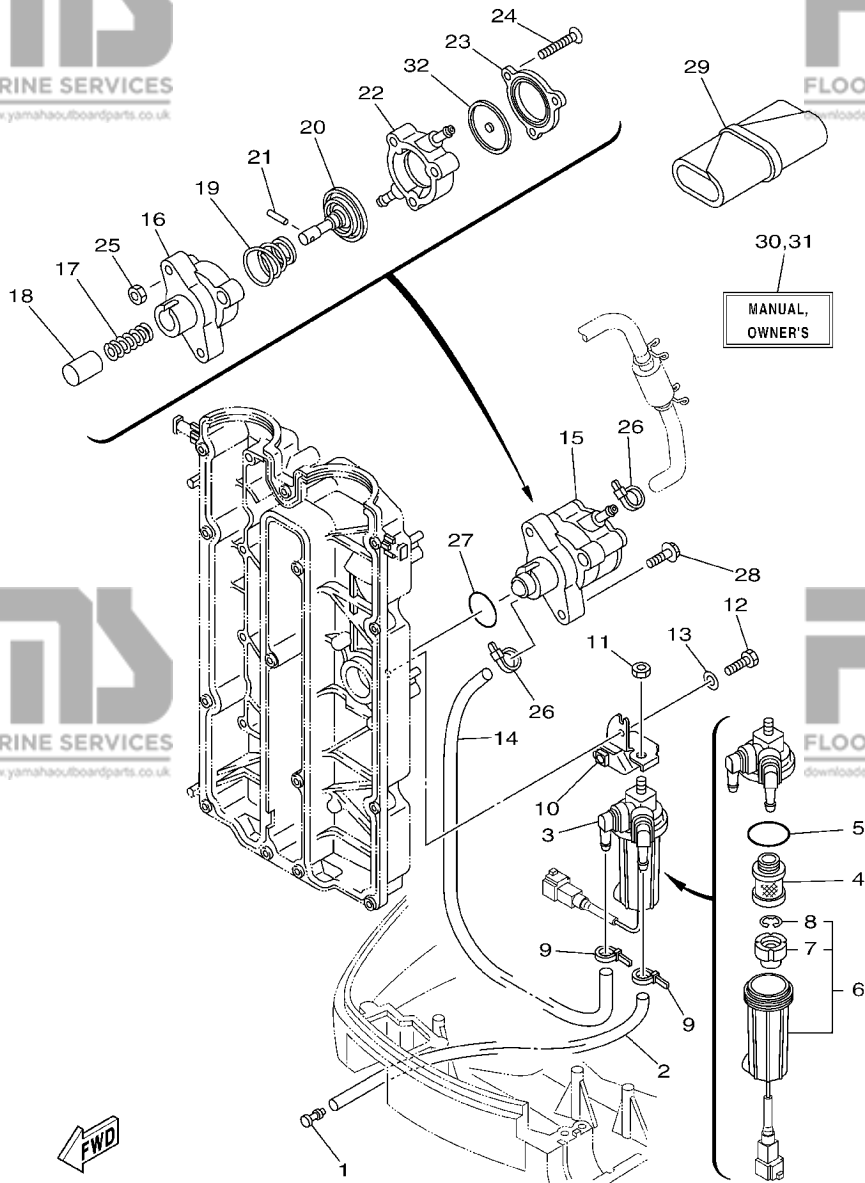

6D74300G1101

**FIG. 11 FUEL**

**CARBURANT**

REF. NO.	PART NO. N° PIECES	DESCRIPTION DESCRIPTION	QTY	REMARKS REMARQUES
1	689-85547-00	DAMPER AMORTISSEUR	1	
2	90445-13M37	HOSE (L2300) DURITE (L2300)	1	
3	6D8-24560-00	FILTER ASSY ENS FILTRE	1	
4	6D8-24563-00	.ELEMENT, FILTER .ELEMENT, FILTRE	1	
5	6D8-24564-00	.GASKET .JOINT	1	
6	6D8-24562-00	.CUP, FILTER .CUVETTE, FILTRE	1	
7	6D8-24469-00	..FLOAT, WATER LEVEL ..FLOTTEUR	1	
8	6D8-24519-00	..CLIP ..JONC	1	
9	90465-11M10	CLAMP BRIDE	2	
10	6D8-24566-00	BRACKET, FILTER SUPPORT, FILTRE	1	
11	95380-08600	NUT ECROU	1	
12	97095-06016	BOLT BOULON	1	
13	92995-06600	WASHER RONDELLE	1	
14	6D8-24311-00	PIPE, FUEL 1 DURITE A ESSENCE	1	
15	6D8-24410-10	FUEL PUMP ASSY POMPE A ESSENCE	1	
16	68V-24412-00	.BODY 1 .CORPS 1	1	
17	68V-24454-00	.SPRING .RESSORT	1	
18	63P-13131-00	.PLUNGER .PLONGEUR	1	
19	68V-24423-00	.SPRING, DIAPHRAGM .RESSORT, DIAPHRAGME	1	
20	68V-24411-00	.DIAPHRAGM .DIAPHRAGME	1	
21	68V-24374-00	.PIN .GOUILLE	1	
22	68V-24413-00	.BODY 2 .CORPS 2	1	
23	6D8-24414-00	.BODY 3 .CORPS 3	1	
24	68V-24444-00	.SCREW .VIS	3	
25	68V-24149-00	.NUT .ECROU	3	
26	90465-11M10	CLAMP BRIDE	2	
27	93210-30682	O-RING JOINT TORIQUE	1	

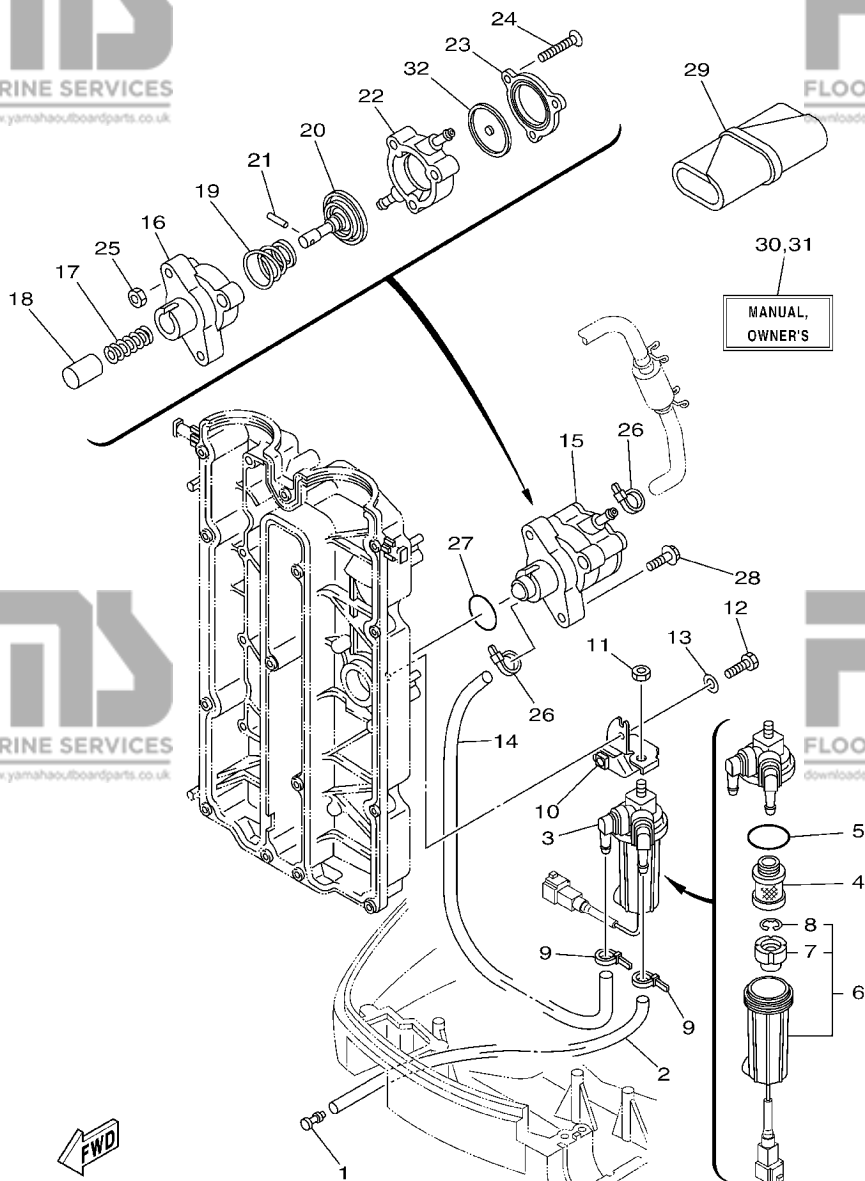

**FIG. 11 FUEL**

**CARBURANT**

REF. NO.	PART NO. N° PIECES	DESCRIPTION DESCRIPTION	60K2	REMARKS REMARQUES
28	90119-06M83	BOLT, WITH WASHER BOULON, AVEC RONDELLE	2	
29	67F-28100-01	TOOL KIT TROUSSE A OUTILS	1	
30	6D7-28199-76-E0	MANUAL, OWNER'S MANUEL D'UTILISATION	1	UR (E) UR (E)
	6D7-28199-76-F0	MANUAL, OWNER'S MANUEL D'UTILISATION	1	UR (F) UR (F)
	6D7-28199-76-S0	MANUAL, OWNER'S MANUEL D'UTILISATION	1	UR (ES) UR (ES)
	6D7-28199-76-G0	MANUAL, OWNER'S MANUEL D'UTILISATION	1	UR (D) UR (D)
	6D7-28199-76-D0	MANUAL, OWNER'S MANUEL D'UTILISATION	1	UR (NL) UR (NL)
	6D7-28199-76-H0	MANUAL, OWNER'S MANUEL D'UTILISATION	1	UR (I) UR (I)
31	6D7-28199-86-K0	MANUAL, OWNER'S MANUEL D'UTILISATION	1	UR (DK) UR (DK)
	6D7-28199-86-R0	MANUAL, OWNER'S MANUEL D'UTILISATION	1	UR (GR) UR (GR)
	6D7-28199-86-P0	MANUAL, OWNER'S MANUEL D'UTILISATION	1	UR (P) UR (P)
	6D7-28199-86-N0	MANUAL, OWNER'S MANUEL D'UTILISATION	1	UR (N) UR (N)
	6D7-28199-86-M0	MANUAL, OWNER'S MANUEL D'UTILISATION	1	UR (S) UR (S)
	6D7-28199-86-L0	MANUAL, OWNER'S MANUEL D'UTILISATION	1	UR (SF) UR (SF)
32	68V-24471-10	.DIAPHRAGM .DIAPHRAGME	1	

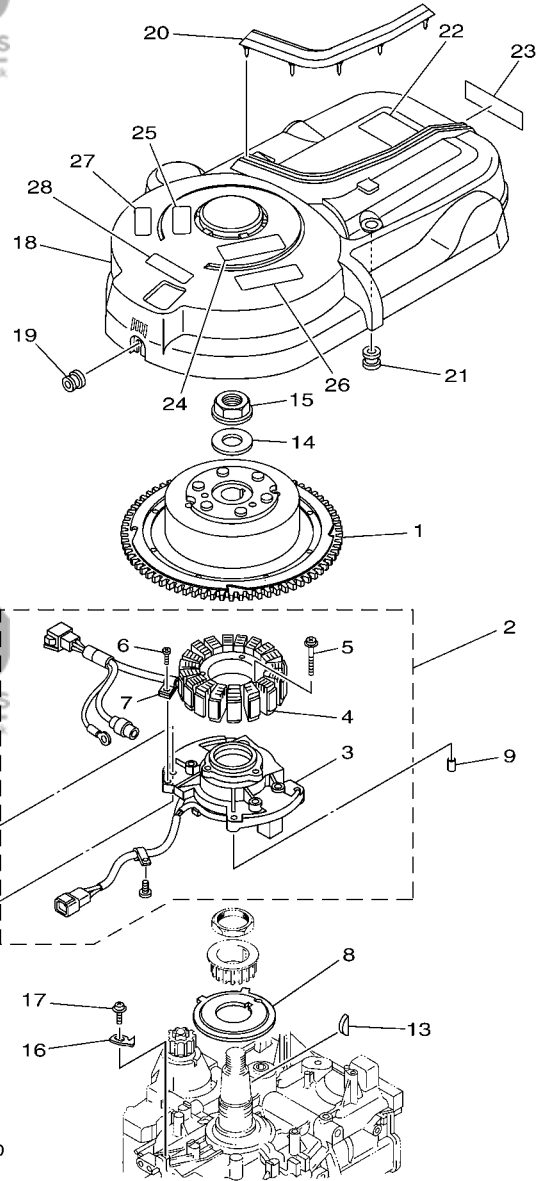

6CK2300-J120

**FIG. 12 GENERATOR**

**GENERATRICE**

REF. NO.	PART NO. N° PIECES	DESCRIPTION DESCRIPTION	6CK2	REMARKS REMARQUES
1	6D8-81450-00	ROTOR ASSY ROTOR COMPLET	1	
2	6D8-81460-00	BASE ASSY ENS. FLASQUE	1	
3	6D8-85580-00	.COIL, PULSER .BOBINE, PULSEUR	1	
4	6D8-81410-00	.STATOR ASSY .STATOR COMPLET	1	
5	63D-81345-20	.SCREW, WITH WASHER (M6X30) .VIS, AVEC RONDELLE (M6X30)	3	
6	97607-04110	.SCREW, WITH WASHER .VIS HEXAGONAL	1	
7	445-81328-20	.CLAMP .COLLIER	1	
8	68V-81673-00	ROTOR ROTOR	1	
9	99530-08012	PIN, DOWEL GOUJON, D'ASSEMBLAGE	2	
10	97095-06030	BOLT BOULON	4	
11	92995-06100	WASHER, SPRING RONDELLE, GROWER	4	
12	92995-06600	WASHER RONDELLE	4	
13	90280-05015	KEY, WOODRUFF CLAVETTE, DEMI-LUNE	1	
14	90201-24014	WASHER, PLATE RONDELLE, PLATE	1	
15	90179-24002	NUT ECROU	1	
16	6D8-81332-00	PLATE, TIMING PLATEAU, ALLUMAGE	1	
17	97985-06210	SCREW, WITH WASHER VIS, AVEC RONDELLE	1	
18	6D8-81337-00	COVER, FLYWHEEL COUVERCLE, VOLANT	1	
19	90480-12072	GROMMET PASSE-FIL	1	
20	6D8-85547-00	DAMPER AMORTISSEUR	1	
21	663-82317-01	DAMPÉR, IGNITION COIL AMORTISSEUR, BOBINE D'ALLUM	2	
22	67F-12138-60	MARK, CAUTION MAKER	1	
23	68V-13437-62	MARK, CAUTION MAKER	1	
24	6AH-81995-40	LABEL, WARNING ETIQUETTE, AVERTISSEMENT	1	
25	6AH-81995-50	LABEL, WARNING ETIQUETTE, AVERTISSEMENT	1	
26	6AH-81994-40	LABEL, SAFETY ETIQUETTE, SECURITE	1	
27	6AH-81994-50	LABEL, SAFETY ETIQUETTE, SECURITE	1	

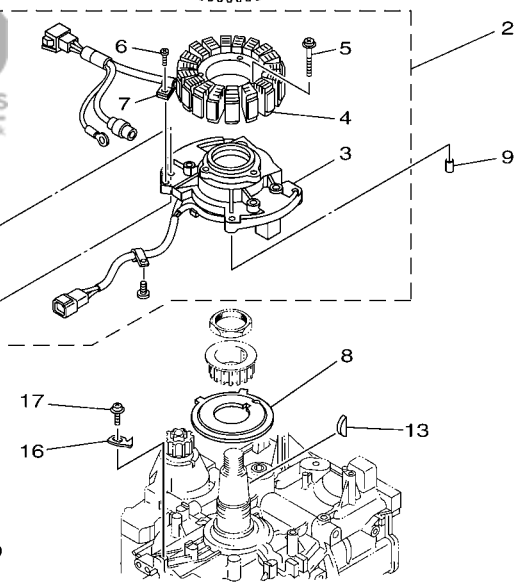
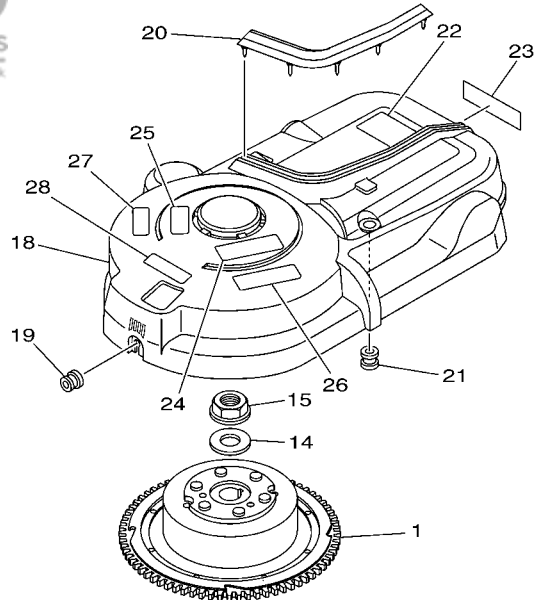

6CK2300-J120

FIG. 12 GENERATOR

GENERATRICE

REF. NO.	PART NO. N° PIECES	DESCRIPTION DESCRIPTION	6CK2	REMARKS REMARQUES
28	6AG-81996-00	MARK MARQUE	1	

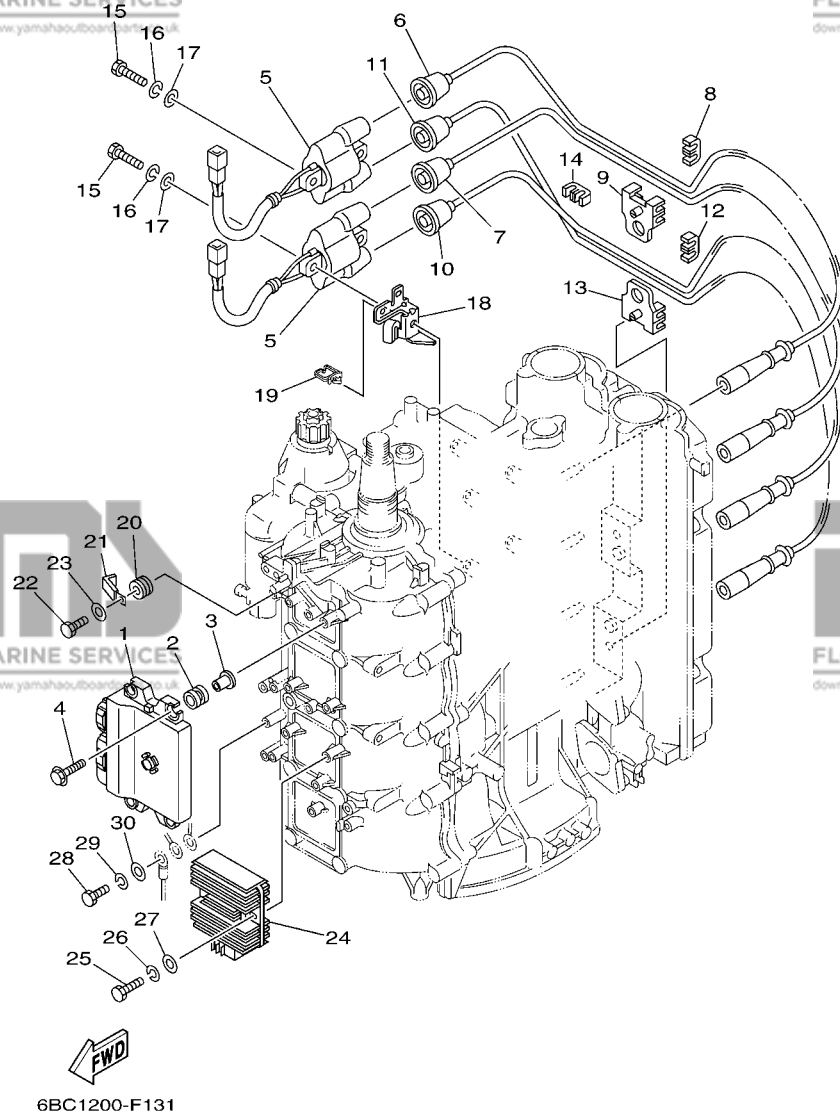

6BC1200-F131

**FIG. 13 ELECTRICAL 1**

**PARTIE ELECTRIQUE 1**

REF. NO.	PART NO. N° PIECES	DESCRIPTION DESCRIPTION	QTY	6CK2	REMARKS REMARQUES
1	6D7-8591A-13	ENGINE CONTROL UNIT ASSY BLOC DE CONTROL	1		
2	68V-82317-00	DAMPER, IGNITION COIL AMORTISSEUR, BOBINE D'ALLUM	4		
3	90387-06119	COLLAR COLLERETTE	4		
4	90119-06M59	BOLT, WITH WASHER BOULON, AVEC RONDELLE	4		
5	63P-82310-01	IGNITION COIL ASSY BOBINE D'ALLUMAGE	2		
6	67F-82341-00	CORD, HIGH TENSION 1 CORDON, HAUTE-TENSION 1	1		#1
7	67F-82342-00	CORD, HIGH TENSION 2 CORDON, HAUTE-TENSION 2	1		#2
8	67F-82361-00	CLAMP, CORD COLLIER, CORDON	1		
9	67F-82362-00	CLAMP, CORD 2 COLLIER, CABLE 2	1		
10	67F-82343-00	CORD, HIGH TENSION 3 CORDON, HAUTE-TENSION 3	1		#3
11	67F-82344-00	CORD, HIGH TENSION 4 CORDON, HAUTE TENSION 4	1		#4
12	67F-82361-00	CLAMP, CORD COLLIER, CORDON	1		
13	67F-82362-00	CLAMP, CORD 2 COLLIER, CABLE 2	1		
14	67F-82361-00	CLAMP, CORD COLLIER, CORDON	1		
15	97095-06025	BOLT BOULON	4		
16	92995-06100	WASHER, SPRING RONDELLE, GROWER	4		
17	92995-06600	WASHER RONDELLE	4		
18	6D8-82388-01	PLATE PLAQUETTE	2		
19	90464-08004	CLAMP BRIDE	2		
20	90480-14329	GROMMET PASSE-FIL	1		
21	90465-08M23	CLAMP BRIDE	1		
22	97095-06014	BOLT BOULON	1		
23	92995-06600	WASHER RONDELLE	1		
24	6D3-81960-00	RECTIFIER & REGULATOR ASSY REDRESSEUR REGULATEUR CPLT	1		
25	97095-06025	BOLT BOULON	2		
26	92995-06100	WASHER, SPRING RONDELLE, GROWER	2		
27	92995-06600	WASHER RONDELLE	2		

FIG. 13 ELECTRICAL 1

PARTIE ELECTRIQUE 1

REF. NO.	PART NO. N° PIECES	DESCRIPTION DESCRIPTION	6CK2	REMARKS REMARQUES
28	97095-06016	BOLT BOULON	1	
29	92995-06100	WASHER, SPRING RONDELLE, GROWER	1	
30	92995-06600	WASHER RONDELLE	1	

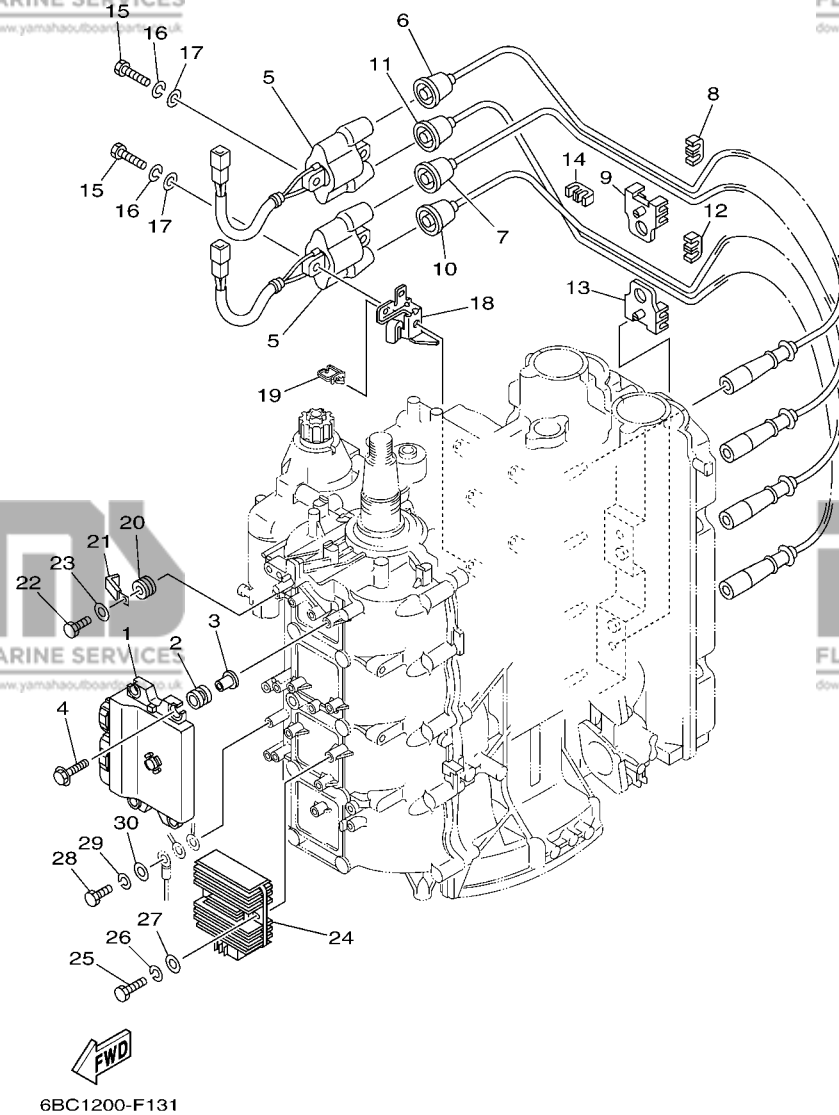
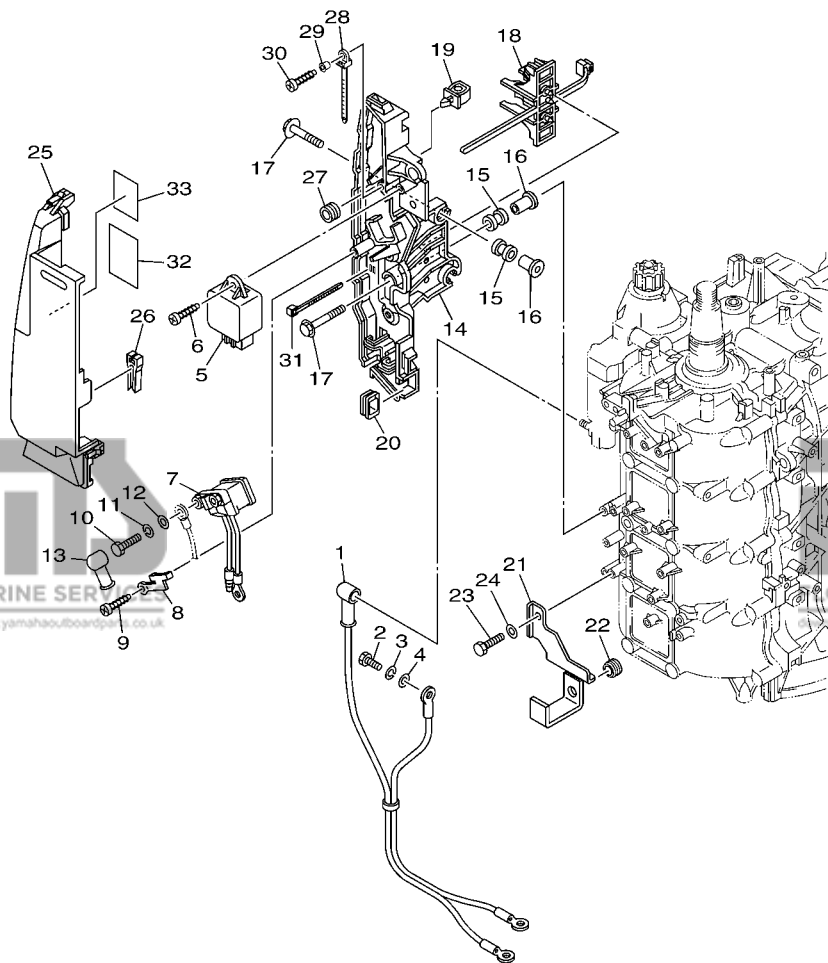

FIG. 14 ELECTRICAL 2

PARTIE ELECTRIQUE 2



6BC1200-F140

REF. NO.	PART NO. N° PIECES	DESCRIPTION DESCRIPTION	6CK2	REMARKS REMARQUES
1	68V-82105-00	WIRE HARNESS FAISCEAU DE FILS	1	
2	97013-06020	BOLT BOULON	1	
3	92903-06100	WASHER, SPRING RONDELLE, GROWER	1	
4	92903-06600	WASHER, PLATE RONDELLE, PLATE	1	
5	60E-81950-00	RELAY ASSY RELAIS COMPLET	1	
6	97780-60625	SCREW, TAPPING VIS, TETE BOMBEE	1	
7	68V-8194A-00	RELAY RELAIS	1	
8	68V-81953-00	STAY, RELAY SUPPORT, RELAIS	1	
9	97780-60620	SCREW, TAPPING VIS, TETE BOMBEE	1	
10	97095-06010	BOLT BOULON	2	
11	92995-06100	WASHER, SPRING RONDELLE, GROWER	2	
12	92995-06600	WASHER RONDELLE	2	
13	6G5-82119-00	COVER, LEAD WIRE GARNITURE, FIL	2	
14	68V-81948-02	BRACKET SUPPORT	1	
15	6A0-82317-00	DAMPER, IGNITION COIL AMORTISSEUR, BOBINE D'ALLUM	5	
16	90387-06119	COLLAR COLLERETTE	5	
17	90119-06M59	BOLT, WITH WASHER BOULON, AVEC RONDELLE	5	
18	68V-82594-00	CLAMP BRIDE	1	
19	90464-12M58	CLAMP BRIDE	1	
20	6D8-81518-00	GROMMET PASSE-FIL	1	
21	6D8-81528-00	CLAMP 1 COLLIER 1	1	
22	90480-13M24	GROMMET PASSE-FIL	1	
23	97095-06014	BOLT BOULON	1	
24	92995-06600	WASHER RONDELLE	1	
25	68V-81942-03	COVER COUVERCLE	1	
26	67F-2812A-00	PULLER, FUSE TENDEUR, FUSIBLE	1	
27	6A0-82317-00	DAMPER, IGNITION COIL AMORTISSEUR, BOBINE D'ALLUM	1	



FIG. 14 ELECTRICAL 2

PARTIE ELECTRIQUE 2

REF. NO.	PART NO. N° PIECES	DESCRIPTION DESCRIPTION	6CK2	REMARKS REMARQUES
28	90465-12M53	CLAMP BRIDE	1	
29	90387-06M05	COLLAR COLLERETTE	1	
30	97780-60625	SCREW, TAPPING VIS, TETE BOMBEE	1	
31	90465-13M18	CLAMP BRIDE	2	
32	68V-81919-00	GRAPHIC, REGULATOR ADHESIF, REGULATEUR	1	
33	6D8-81919-00	GRAPHIC, REGULATOR ADHESIF, REGULATEUR	1	

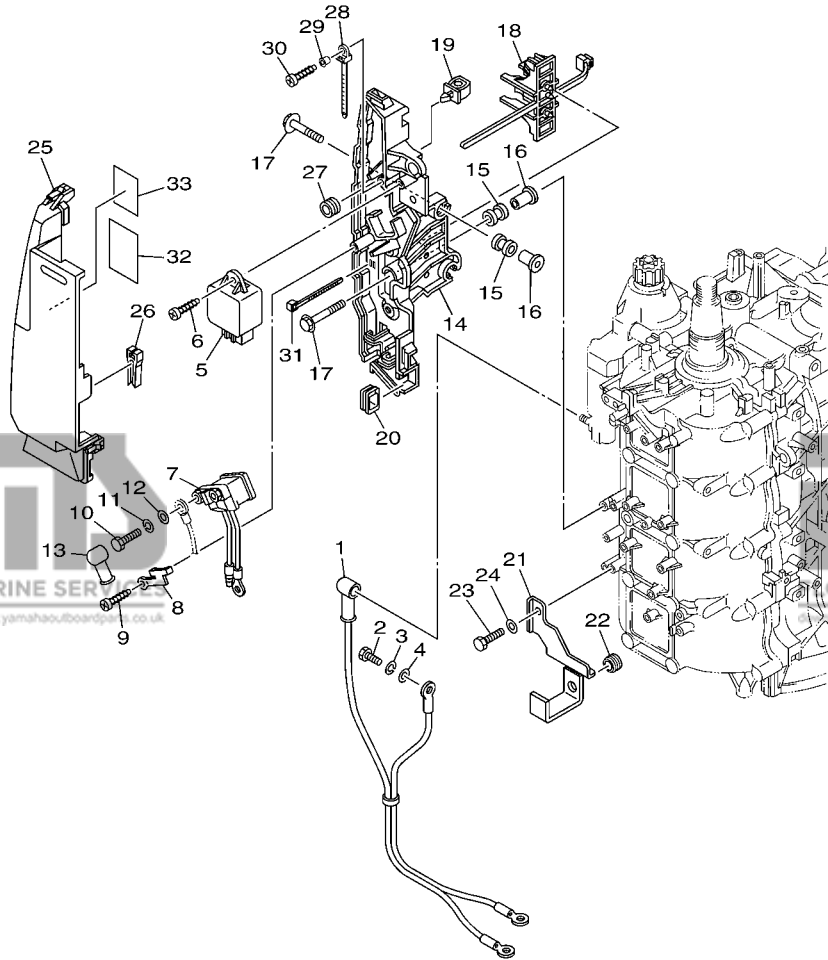

**FWD**  
6BC1200-F140

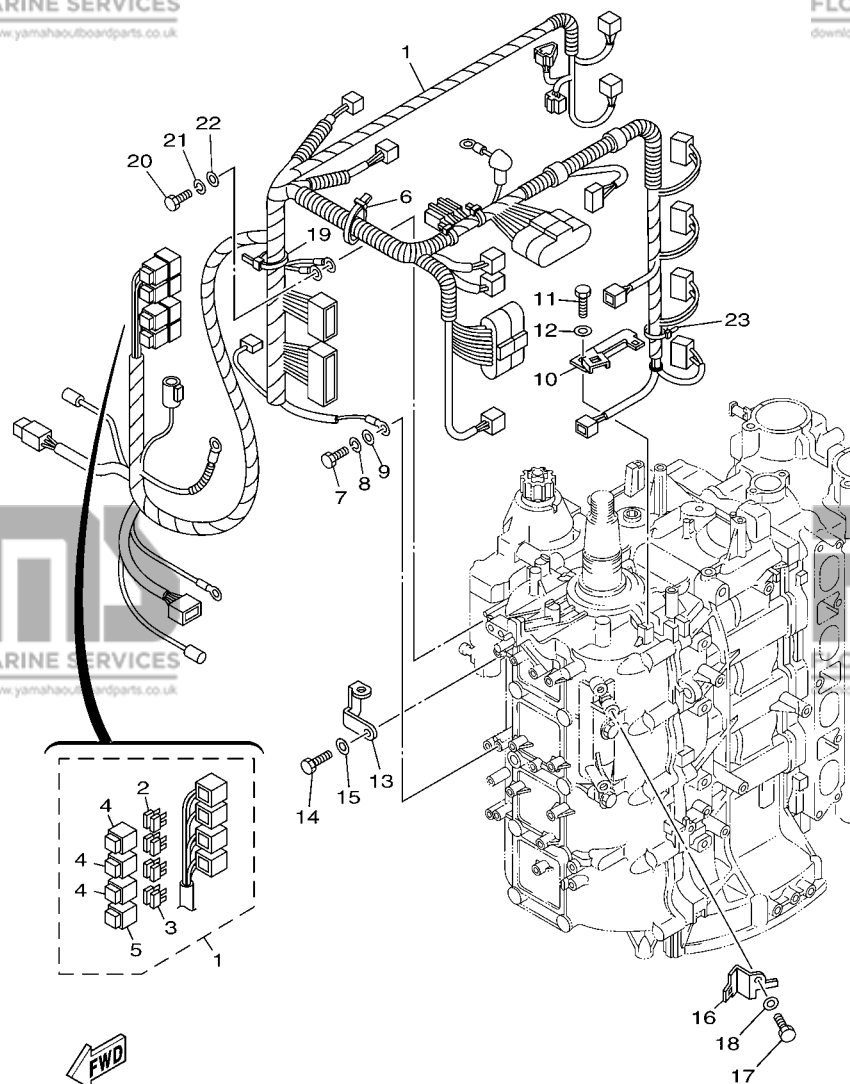

6BC1200-F150

**FIG. 15 ELECTRICAL 3**

**PARTIE ELECTRIQUE 3**

REF. NO.	PART NO. N° PIECES	DESCRIPTION DESCRIPTION	60K2	REMARKS REMARQUES
1	6BC-82590-00	WIRE HARNESS ASSY FAISCEAU DE FILS COMPLET	1	
2	67F-82151-00	.FUSE (20A) .FUSIBLE (20A)	6	
3	67F-82151-10	.FUSE (30A) .FUSIBLE (30A)	2	
4	67F-8215B-10	.CAP (YELLOW) .BOUCHON (YELLOW)	3	
5	67F-8215B-20	.CAP (GREEN) .BOUCHON (GREEN)	1	
6	90464-76001	CLAMP BRIDE	1	
7	97095-06016	BOLT BOULON	1	
8	92995-06100	WASHER, SPRING RONDELLE, GROUVER	1	
9	92995-06600	WASHER RONDELLE	1	
10	6D8-82588-00	PLATE PLAQUE	1	
11	97095-06012	BOLT BOULON	1	
12	92995-06600	WASHER RONDELLE	1	
13	6D8-82581-00	STAY, CORD CLAMP SUPPORT, COLLIER DE CORDON	1	
14	97095-06014	BOLT BOULON	1	
15	92995-06600	WASHER RONDELLE	1	
16	6D8-82389-00	PLATE 2 PLAQUETTE 2	1	
17	97095-06012	BOLT BOULON	1	
18	92995-06600	WASHER RONDELLE	1	
19	90465-13M18	CLAMP BRIDE	1	
20	97095-06016	BOLT BOULON	1	
21	92995-06100	WASHER, SPRING RONDELLE, GROUVER	1	
22	92995-06600	WASHER RONDELLE	1	
23	90465-13M11	CLAMP BRIDE	1	

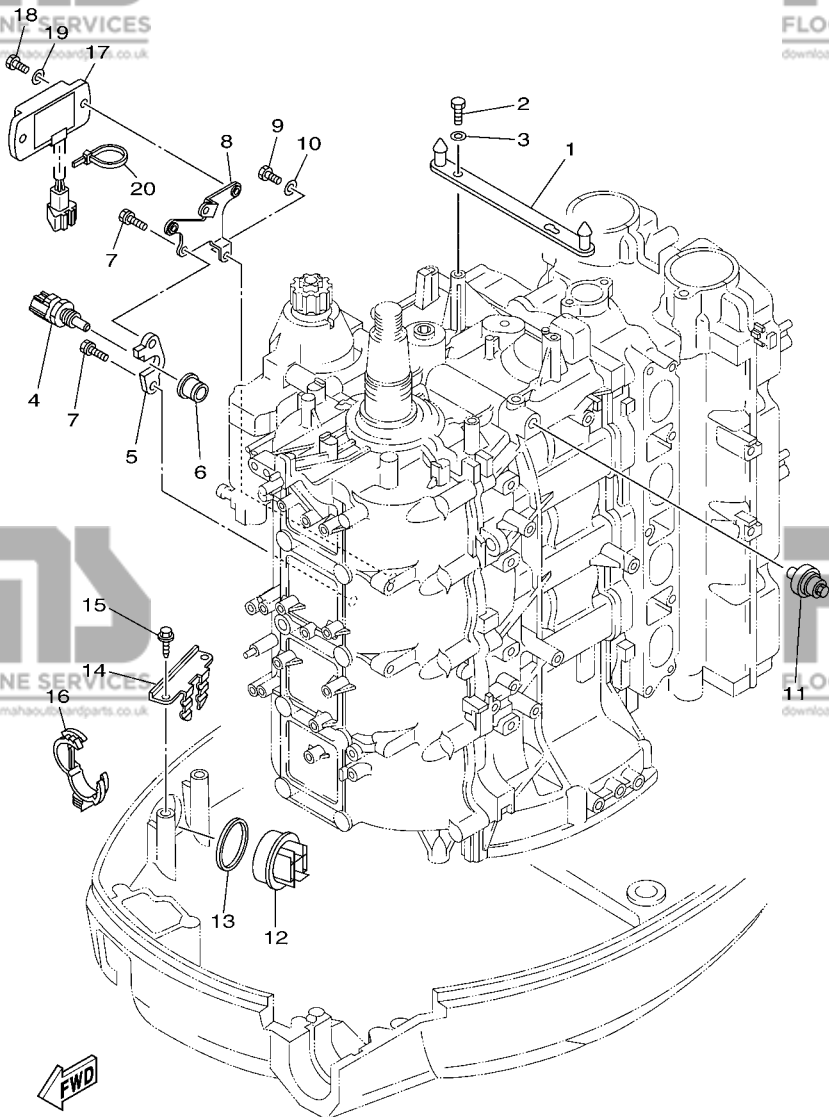

6BC3200-H160

FIG. 16 ELECTRICAL 4

PARTIE ELECTRIQUE 4

REF. NO.	PART NO. N° PIECES	DESCRIPTION DESCRIPTION	QTY	REMARKS REMARQUES
1	6D8-8132G-00	PLATE PLAQUE	1	
2	97095-06016	BOLT BOULON	2	
3	92995-06600	WASHER RONDELLE	2	
4	67F-85790-00	THERMOSENSOR ASSY SENSITOMETRE	1	
5	67F-85757-00	RETAINER ARRETOIR	1	
6	68V-85753-00	GASKET, SENDER UNIT JOINT, DE PERCEPTION	1	
7	90119-06MA2	BOLT, WITH WASHER BOULON, AVEC RONDELLE	2	
8	6BC-83519-00	BRACKET, METER SUPPORT, COMPTEUR	1	
9	97095-06012	BOLT BOULON	1	
10	92995-06600	WASHER RONDELLE	1	
11	68V-82504-00	OIL PRESSURE SWITCH ASSY CONTACTEUR DE PRESSION D'HUILE	1	
12	68F-42723-10-8D	COVER, BOTTOM COUVERCLE	1	
13	6E5-82587-00	GASKET JOINT	1	
14	67F-83614-00	BRACKET SUPPORT	1	
15	90109-06M86	BOLT BOULON	2	
16	90464-30003	CLAMP BRIDE	2	
17	6Y5-83504-22	HOUR METER ASSY COMPTEUR D'HEURES (ENS.)	1	
18	97880-05014	SCREW, PAN HEAD VIS, TETE TRONCONIQUE	2	
19	92990-05600	WASHER, PLATE RONDELLE, PLATE	2	
20	90465-11M10	CLAMP BRIDE	1	

**FIG. 17 STARTING MOTOR**

**DEMARREUR ELECTRIQUE**

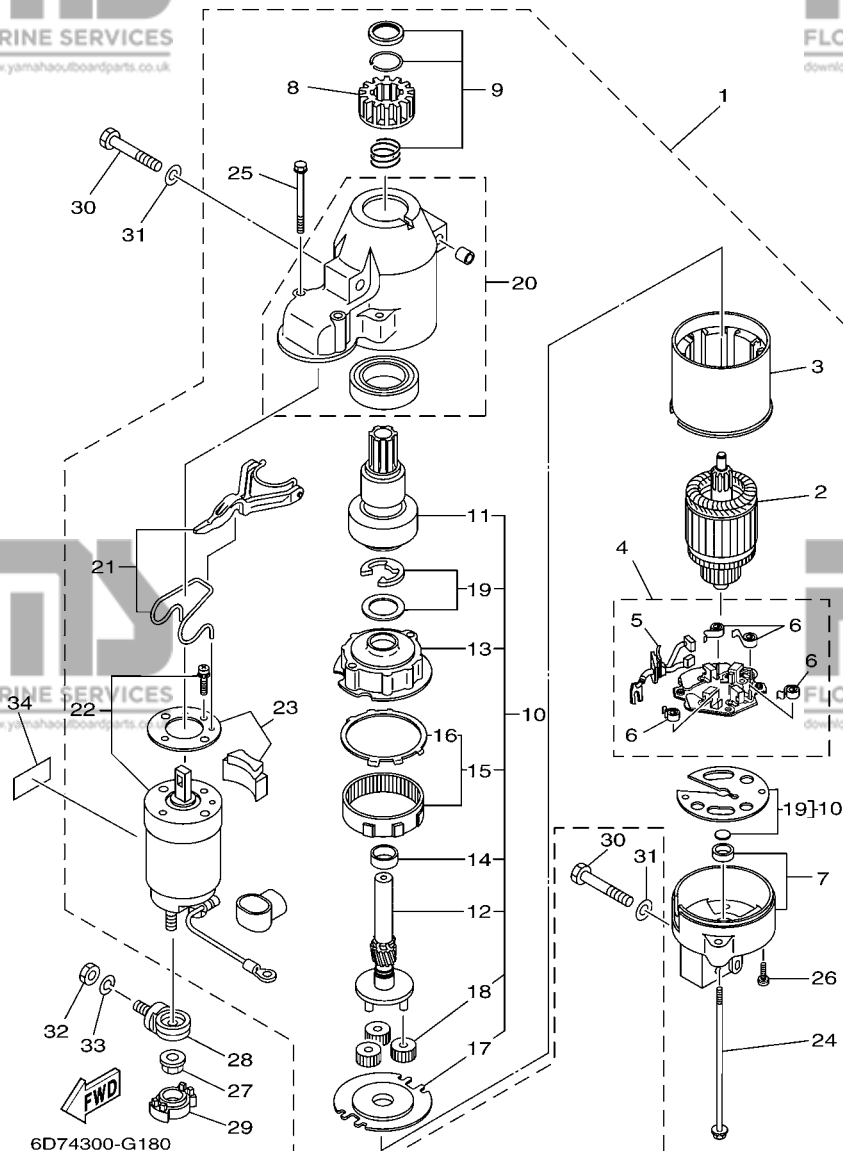

REF. NO.	PART NO. N° PIECES	DESCRIPTION DESCRIPTION	QTY	REMARKS REMARQUES
1	68V-81800-01	STARTING MOTOR ASSY DEMARREUR ELECTRIQUE COMPLET	1	
2	67F-81850-00	.ARMATURE ASSY .INDUIT	1	
3	67F-81810-00	.STATOR ASSY .STATOR COMPLET	1	
4	68F-81840-00	.BRUSH HOLDER ASSY .SUPPORT DE CHARBON	1	
5	67F-81801-00	..BRUSH SET ..CHARBON	1	
6	67F-81813-00	..SPRING, BRUSH ..RESSORT, DE CHARBON	4	
7	68F-81820-00	.REAR BRACKET ASSY .SUPPORT ARRIERE COMPLET	1	
8	67F-81808-00	.PINION ASSY .PIGNON	1	
9	67F-81857-00	.PINION STOPPER SET .BUTEE PIGNON	1	
10	67F-81807-00	.GEAR ASSY, STARTING MOTOR .PIGNON, DEMARREUR ELECTRIQUE	1	
11	67F-81832-00	..CLUTCH, OVER RUN ..EMBAYAGE, ROUE LIBRE	1	
12	67F-81836-00	..SHAFT, PINION ..AXE, PIGNON	1	
13	67F-81821-00	..BRACKET, CENTER 1 ..SUPPORT, CENTRE 1	1	
14	67F-81841-00	..BEARING ..ROULEMENT	1	
15	67F-81891-00	..GEAR, RING ..ROUE DENTEE	1	
16	67F-8183R-00	...GASKET ...JOINT	1	
17	67F-81830-00	..BRACKET, CENTER 2 ..SUPPORT, CENTRE 2	1	
18	60V-8183T-00	..GEAR, IDLER ..PIGNON, INTERMEDIAIRE	3	
19	67F-81809-00	..WASHER KIT ..JEU DE RONDELLES	1	
20	67F-81842-00	.COVER .COUVERCLE	1	
21	67F-81839-00	.LEVER ASSY .LEVIER COMPLET	1	
22	68V-81941-01	.STARTER RELAY ASSY .LANCEUR RELAIS (ENS.)	1	
23	67F-81869-00	.COVER, DUST .COUVERCLE, POUSSIERE	1	
24	6K7-81826-11	.BOLT .BOULON	2	
25	67F-81828-00	.BOLT 2 ..RONDELLE, BUTEE 2	2	
26	67F-81846-00	.SCREW .VIS	2	
27	90179-08003	NUT ECROU	1	

**FIG. 17 STARTING MOTOR**

**DEMARREUR ELECTRIQUE**

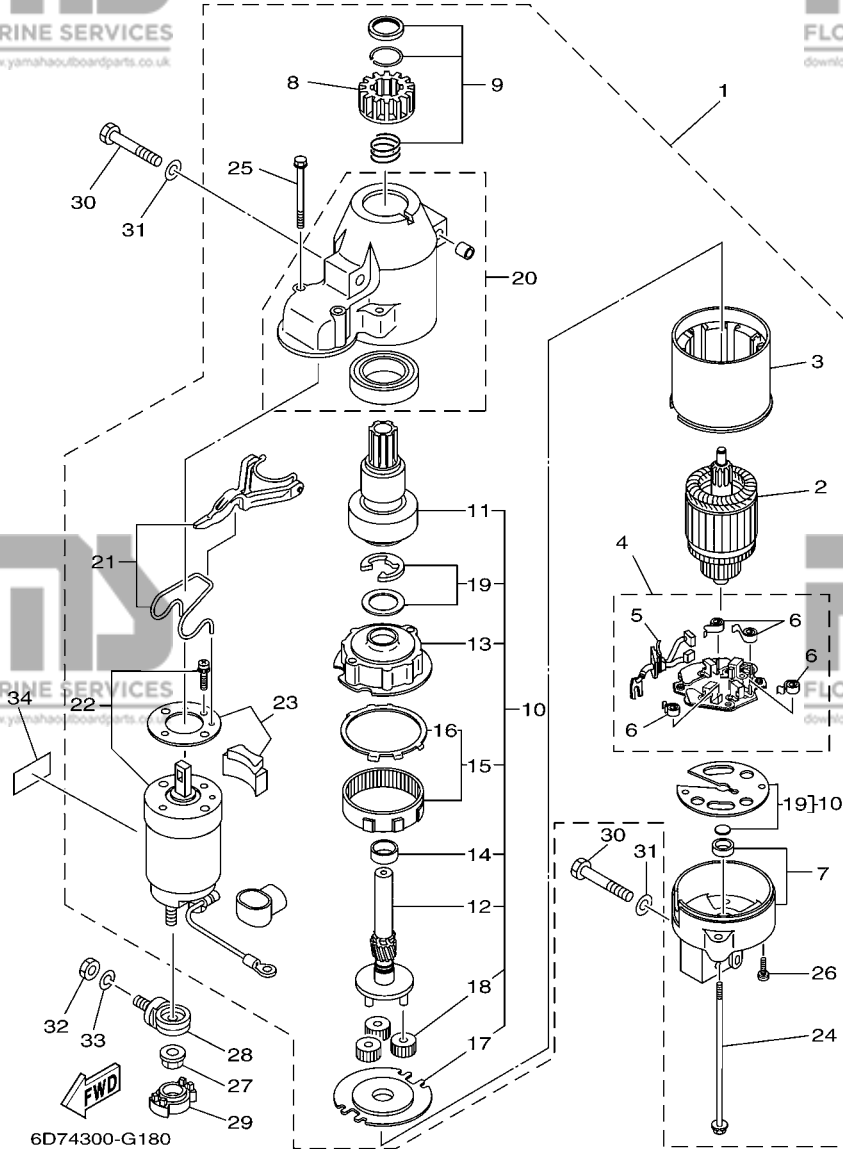

REF. NO.	PART NO. N° PIECES	DESCRIPTION DESCRIPTION	60K2	REMARKS REMARQUES
28	60V-81925-00	TERMINAL BORNE	1	
29	68F-82582-00	COVER, WIRE HARNESS COUVERCLE, FAISCEAU DE FILS	1	
30	97013-08045	BOLT BOULON	3	
31	92903-08600	WASHER, PLATE RONDELLE, PLATE	3	
32	95333-08600	NUT ECROU	1	
33	92903-08100	WASHER, SPRING RONDELLE, GROWER	1	
34	67F-83627-01	LABEL, CAUTION 7 ETIQUETTE, RECOMMANDATION 7	1	

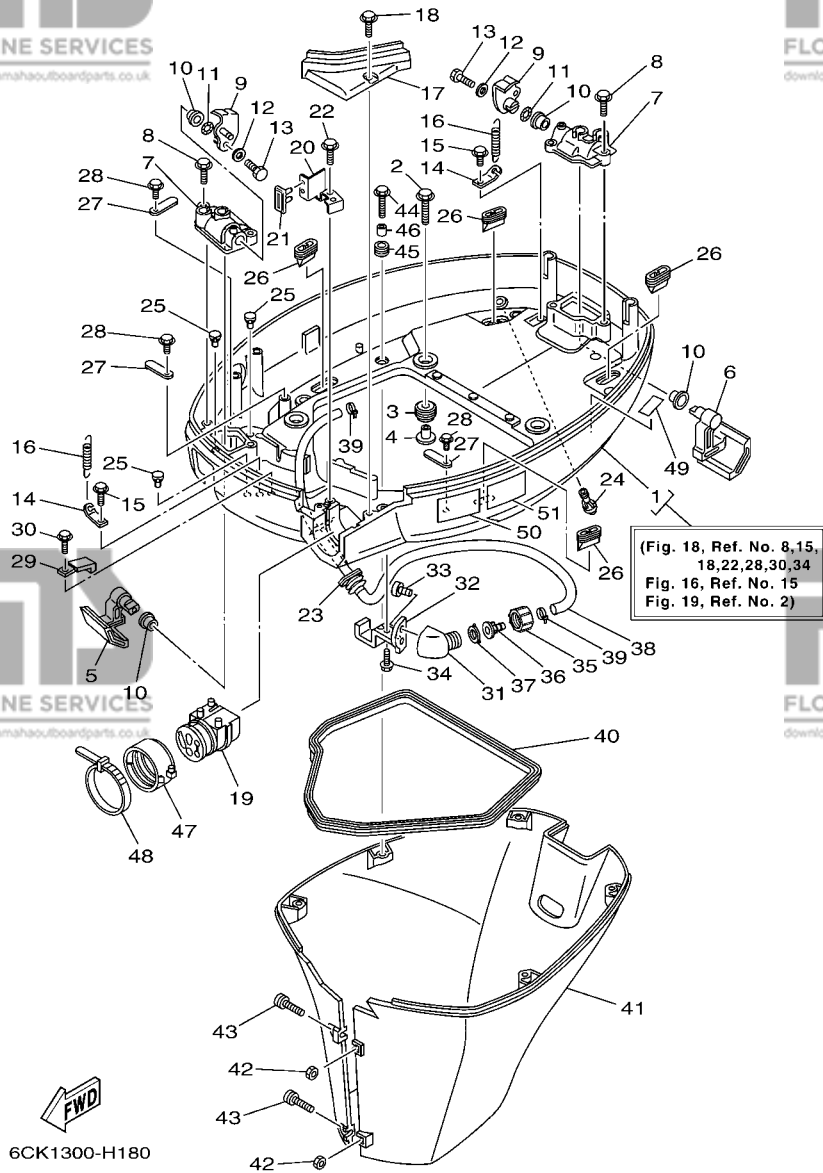

**FIG. 18 BOTTOM COWLING**

**CAPOT INFERIEUR**

REF. NO.	PART NO. N° PIECES	DESCRIPTION DESCRIPTION	6CK2	REMARKS REMARQUES
1	6D8-42710-00-8D	BOTTOM COWLING ASSY ENS. EMBASE	1	
2	90119-08M22	BOLT, WITH WASHER BOULON, AVEC RONDELLE	4	
3	90480-22M15	GROMMET PASSE-FIL	4	
4	90387-08M37	COLLAR COLLERETTE	4	
5	67F-42815-00-8D	LEVER, CLAMP LEVIER, PRESSE	1	
6	67F-42816-00-8D	LEVER, CLAMP LEVIER, PRESSE	1	
7	67F-42828-00-8D	PLATE, CLAMP PLAQUE, PRESSE	2	
8	90109-06M82	BOLT BOULON	4	
9	68V-42818-01	LEVER, CLAMP LEVIER, PRESSE	2	
10	90386-15M73	BUSH DOUILLE	4	
11	90206-15M18	WASHER, WAVE RONDELLE, ONDULEE	2	
12	90201-06068	WASHER, PLATE RONDELLE, PLATE	2	
13	97095-06016	BOLT BOULON	2	
14	64D-43144-00	HOOK, SPRING CROCHET	2	
15	90109-06M86	BOLT BOULON	2	
16	90506-16M34	SPRING, TENSION RESSORT, TENSION	2	
17	67F-42738-00-8D	PLATE, FITTING ETRIER	1	
18	90109-06M96	BOLT BOULON	2	
19	68V-42725-00	GROMMET PASSE-FIL	1	
20	6D8-42756-00	STAY, CLAMP SUPPORT, COLLIER	1	
21	6D8-42717-00	RUBBER, SEAL 2 JOINT EN CAOUTCHOUC 2	1	
22	90109-06M86	BOLT BOULON	1	
23	688-42726-10	GROMMET PASSE-FIL	1	FLUSHING KIT FLUSHING KIT
24	6BL-44391-00	NIPPLE, HOSE RACCORD D'ESSENCE	1	
25	6H4-42748-00	GROMMET PASSE-FIL	3	
26	67F-42717-00	RUBBER, SEAL 2 JOINT EN CAOUTCHOUC 2	4	
27	6E5-82588-00	PLATE PLAQUE	3	

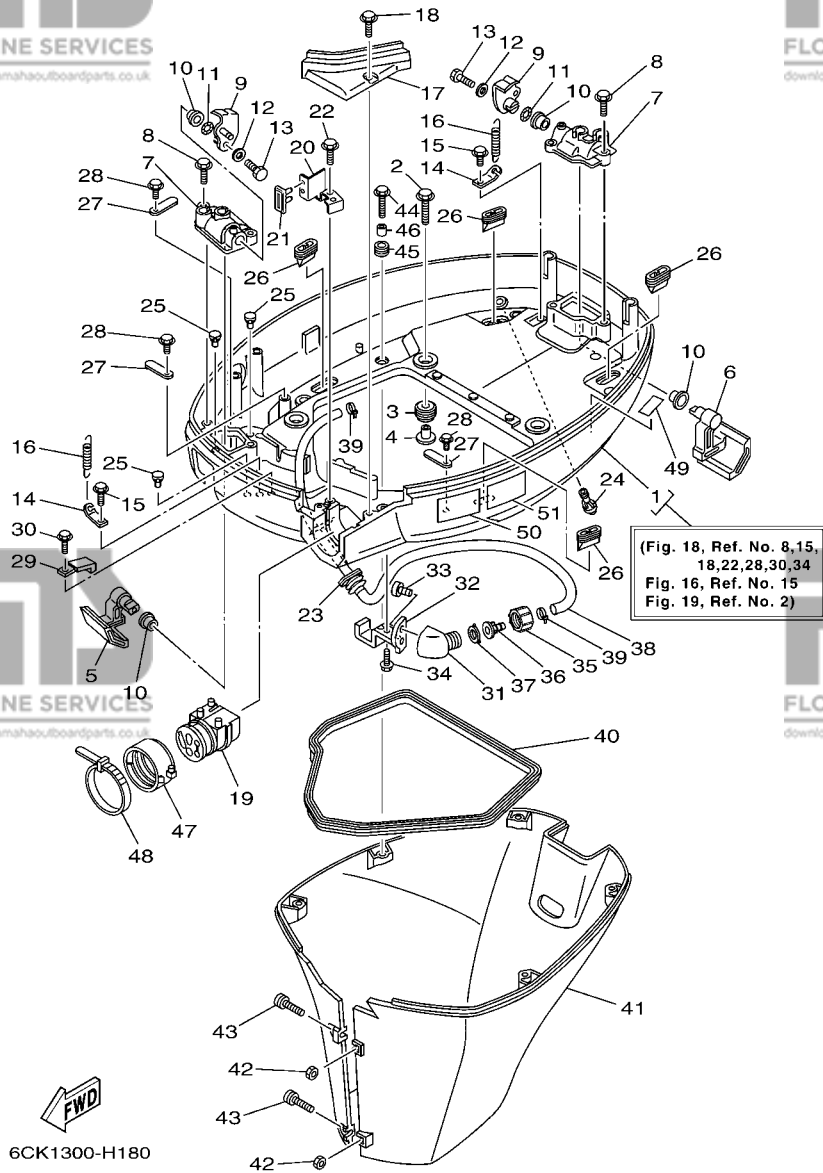

**FIG. 18 BOTTOM COWLING**

**CAPOT INFERIEUR**

REF. NO.	PART NO. N° PIECES	DESCRIPTION DESCRIPTION	6CK2	REMARKS REMARQUES
28	90109-06M81	BOLT BOULON	3	
29	90465-08M23	CLAMP BRIDE	1	
30	90109-06M86	BOLT BOULON	1	
31	68T-12572-00	ADAPTER ADAPTATEUR	1	FLUSHING KIT FLUSHING KIT
32	67F-12535-01	PLATE PLAQUE	1	FLUSHING KIT FLUSHING KIT
33	90167-06002	SCREW, TAPPING VIS, TETE FRAISEE	2	FLUSHING KIT FLUSHING KIT
34	90109-06M86	BOLT BOULON	1	FLUSHING KIT FLUSHING KIT
35	6R3-12581-00	JOINT, HOSE 1 JOINT DE TUYAU	1	FLUSHING KIT FLUSHING KIT
36	6R3-12582-00	JOINT, HOSE 2 RACCORD DE TUYAU 1	1	FLUSHING KIT FLUSHING KIT
37	6R3-12583-00	GASKET, HOSE JOINT JOINT	1	FLUSHING KIT FLUSHING KIT
38	67F-24312-00	PIPE 2 DURITE 2	1	FLUSHING KIT FLUSHING KIT
39	90465-11M10	CLAMP BRIDE	2	FLUSHING KIT FLUSHING KIT
40	61A-42716-00	RUBBER, SEAL 1 JOINT EN CAOUTCHOUC 1	1	
41	67F-42741-01-8D	APRON CAPOT LATERAL	1	
42	95380-06600	NUT, HEXAGON ECROU	2	
43	90159-06M28	SCREW, WITH WASHER VIS, AVEC RONDELLE	2	
44	90109-06M80	BOLT BOULON	5	
45	90480-13M24	GROMMET PASSE-FIL	5	
46	90387-06M43	COLLAR COLLERETTE	5	
47	68F-42753-00	FASTNER ATTACHE	1	AP AP
48	90464-20258	CLAMP BRIDE	1	AP AP
49	67F-82377-00	LABEL ETIQUETTE	1	
50	6AH-42794-40	LABEL, WARNING (GENERAL) ETIQUETTE, AVERTISSEMENT	1	
51	6AH-42794-50	LABEL, WARNING (GENERAL) ETIQUETTE, AVERTISSEMENT	1	

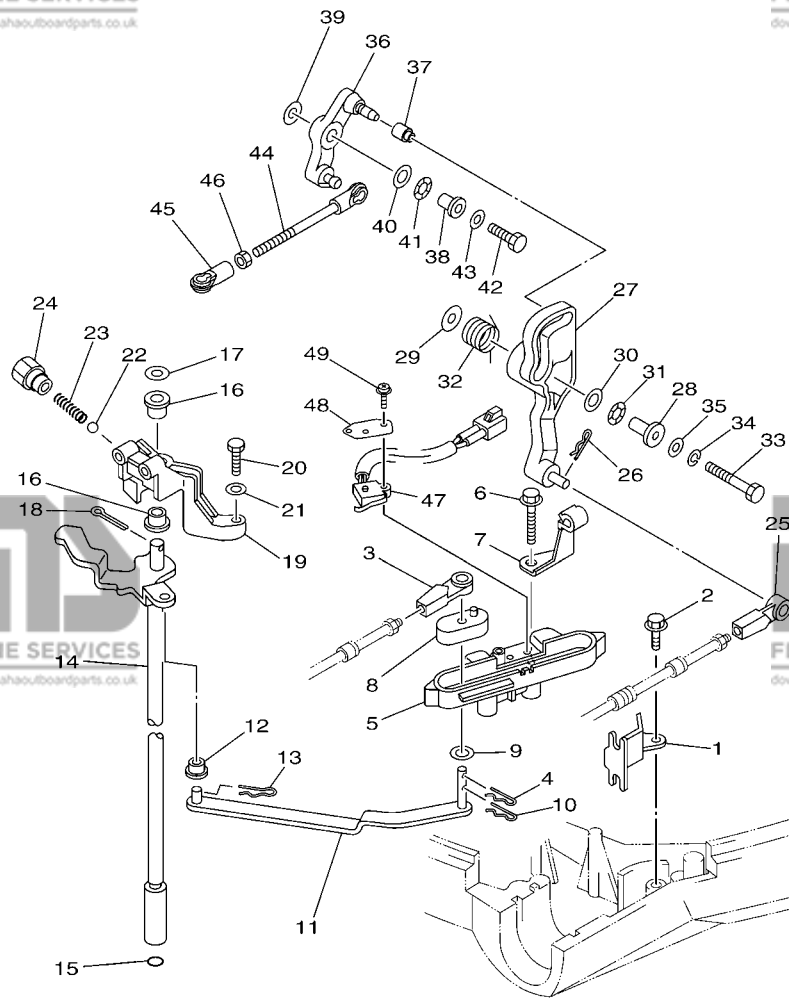

6CK2300-J190

**FIG. 19 CONTROL**

**COMMANDE**

REF. NO.	PART NO. N° PIECES	DESCRIPTION DESCRIPTION	6CK2	REMARKS REMARQUES
1	67F-48538-00	CLAMP, CABLE 1 COLLIER	1	
2	90109-06M86	BOLT BOULON	1	
3	663-48344-00	CABLE END, REMOTE CONTROL CHAPE CABLE	1	
4	90468-18008	CLIP JONC	1	
5	6D8-44117-00	BRACKET SUPPORT	1	
6	97595-06550	BOLT, WITH WASHER VIS HEXAGONAL AVC RONDELLE	2	
7	90462-10027	CLAMP BRIDE	1	
8	68V-44122-01	BUSHING, SHIFT ROD LEVER DOUILLE, LEVIER D'EMBRAYAGE	1	
9	90202-07M07	WASHER, PLATE RONDELLE, PLATE	1	
10	90468-18008	CLIP JONC	1	
11	67F-44121-00	LEVER, SHIFT ROD LEVIER, TIGE D'INVERSION	1	
12	90386-06M12	BUSH DOUILLE	1	
13	90468-18008	CLIP JONC	1	
14	60C-44120-10	HANDLE GEAR SHIFT ASSY LEVIER D'EMBRAYAGE	1	L(20.3") L(20.3")
15	93210-09165	O-RING JOINT TORIQUE	1	
16	90386-90M90	BUSH DOUILLE	2	
17	90201-09M02	WASHER, PLATE RONDELLE, PLATE	1	
18	91490-20015	PIN, COTTER GOUPILLE	1	
19	68V-44118-00	BRACKET SUPPORT	1	
20	97075-06025	BOLT BOULON	2	
21	92995-06600	WASHER RONDELLE	2	
22	93501-04M02	BALL BILLE	1	
23	90501-12082	SPRING, COMPRESSION RESSORT, COMPRESSION	1	
24	648-42715-00	BUSHING COUSSINET	1	
25	663-48344-00	CABLE END, REMOTE CONTROL CHAPE CABLE	1	
26	90468-18008	CLIP JONC	1	
27	6D8-42154-00	LEVER, THROTTLE CONTROL LEVIER DE COMMANDE D'AVANCE	1	



FIG. 19 CONTROL

COMMANDE

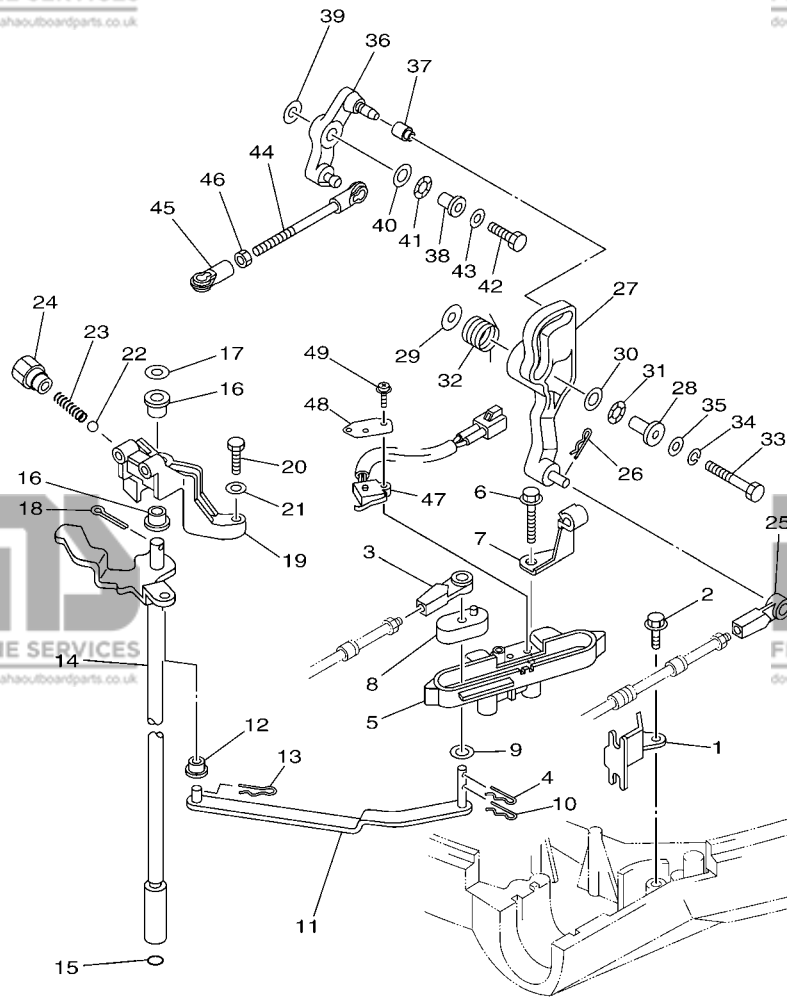

6CK2300-J190

REF. NO.	PART NO. N° PIECES	DESCRIPTION DESCRIPTION	6CK2	REMARKS REMARQUES
28	90387-06M21	COLLAR COLLERETTE	1	
29	90201-06M62	WASHER, PLATE RONDELLE, PLATE	1	
30	90201-10M02	WASHER, PLATE RONDELLE, PLATE	1	
31	90206-10M04	WASHER, WAVE RONDELLE, ONDULEE	1	
32	67F-44135-00	SPRING RESSORT	1	
33	97095-06035	BOLT BOULON	1	
34	92995-06100	WASHER, SPRING RONDELLE, GROWER	1	
35	92995-06600	WASHER RONDELLE	1	
36	6D8-42157-00	LEVER, THROTTLE LEVIER DE AVANCE	1	
37	68V-42171-00	BUSHING COUSSINET	1	
38	90387-06013	COLLAR COLLERETTE	1	
39	90201-06M31	WASHER, PLATE RONDELLE, PLATE	1	
40	90201-10M02	WASHER, PLATE RONDELLE, PLATE	1	
41	90206-10M04	WASHER, WAVE RONDELLE, ONDULEE	1	
42	97095-06025	BOLT BOULON	1	
43	92995-06600	WASHER RONDELLE	1	
44	6D8-41237-00	JOINT, LINK RACCORD	1	
45	682-41237-00	JOINT, LINK RACCORD	1	
46	95380-05600	NUT ECROU	1	
47	60V-8259F-00	SWITCH ASSY COMMUTATEUR	1	
48	61A-82588-01	PLATE PLAQUE	1	
49	97985-04116	SCREW, WITH WASHER VIS, AVEC RONDELLE	2	

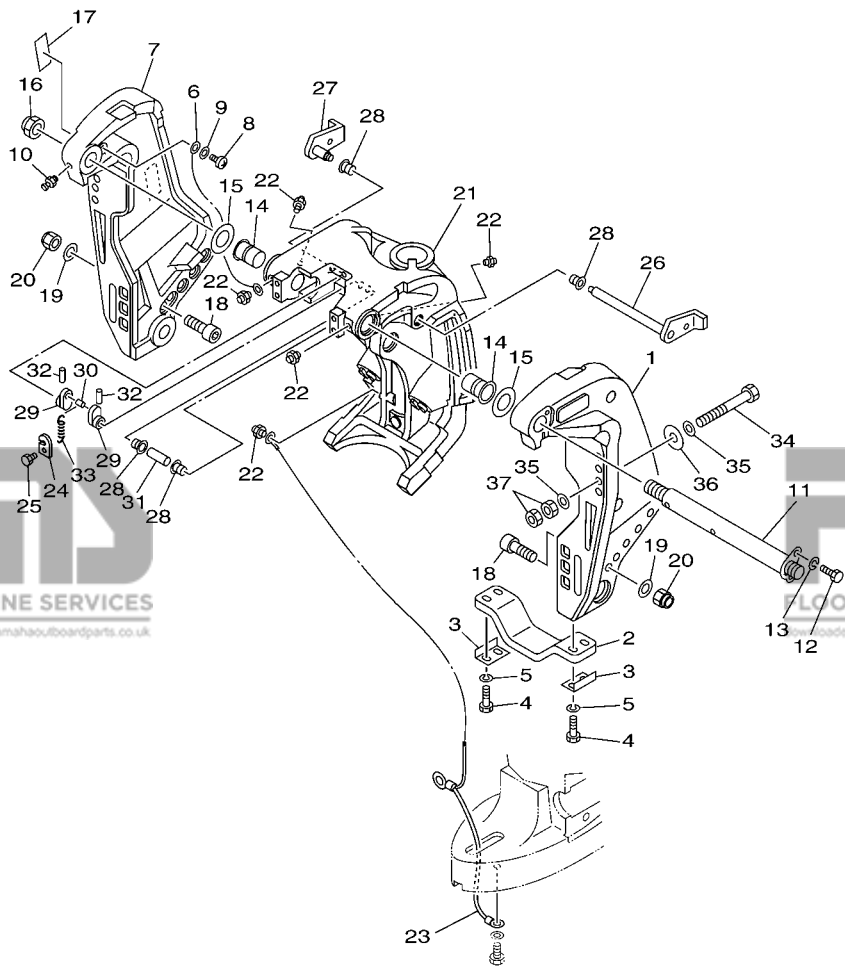

6BC1200-F240

**FIG. 20 BRACKET 1**

**SUPPORT 1**

REF. NO.	PART NO. N° PIECES	DESCRIPTION DESCRIPTION	QTY	REMARKS REMARQUES
1	6BC-43111-00-8D	BRACKET, CLAMP 1 PRESSE 1	1	
2	6G5-45251-02	ANODE ANODE	1	
3	6G5-44526-00	PLATE PLAQUE	2	
4	97095-06030	BOLT BOULON	4	
5	92995-06100	WASHER, SPRING RONDELLE, GROWER	4	
6	6E5-82148-00	WIRE, LEAD 4 FIL 4	1	
7	6BC-43112-00-8D	BRACKET, CLAMP 2 PRESSE 2	1	
8	97885-06012	SCREW, PAN HEAD VIS, A ENCOCHE	1	
9	92995-06600	WASHER RONDELLE	1	
10	93700-06M03	NIPPLE, GREASE PION	1	
11	64E-43131-01	BOLT, CLAMP BRACKET BOULON, PRESSE	1	
12	97095-08020	BOLT BOULON	1	
13	92995-08100	WASHER RONDELLE	1	
14	90386-25M31	BUSH DOUILLE	2	
15	90201-26M59	WASHER, PLATE RONDELLE, PLATE	2	
16	90185-22M11	NUT, SELF-LOCKING ECROU, AUTO-BLOQUANT	1	
17	63D-43691-00	INDICATOR, TILT ETIQUETTE, RELEVAGE	1	
18	90110-12M00	BOLT, HEXAGON SOCKET HEAD BOULON, TETE HEXAGONALE CREUSE	2	
19	92990-12200	WASHER, PLAIN RONDELLE, PLATE	2	
20	90185-12M12	NUT, SELF-LOCKING ECROU, AUTO-BLOQUANT	2	
21	6BC-43311-00-8D	BRACKET, SWIVEL 1 SUPPORT, PIVOT 1	1	L(20.3") L(20.3")
22	93700-06M03	NIPPLE, GREASE PION	5	
23	66K-82149-00	WIRE, LEAD 3 FIL 3	1	L(20.3") L(20.3")
24	66T-43144-00	HOOK, SPRING CROCHET	1	
25	97095-06010	BOLT BOULON	1	
26	6BC-43181-00	LEVER, TILT STOP LEVIER, VERROUILLAGE RELEVAGE	1	
27	6BC-43185-00	LEVER, TILT STOP LEVIER, VERROUILLAGE RELEVAGE	1	

**FIG. 20 BRACKET 1**

**SUPPORT 1**

REF. NO.	PART NO. N° PIECES	DESCRIPTION DESCRIPTION	6CK2	REMARKS REMARQUES
28	90386-10M16	BUSH DOUILLE	4	
29	6G5-43148-00	COLLAR, DISTANCE ENTRETOISE	2	
30	90249-06M19	PIN GOUPILLE	1	
31	90387-10M05	COLLAR COLLERETTE	1	
32	91690-30020	PIN, SPRING AGRAFFE	2	
33	90506-14M24	SPRING, TENSION RESSORT, TENSION	1	
34	90101-12M03	BOLT (L:115MM) BOULON (L:115MM)	4	
35	90201-13M01	WASHER, PLATE RONDELLE, PLATE	8	
36	90201-12M05	WASHER, PLATE RONDELLE, PLATE	4	
37	95380-12600	NUT ECROU	8	

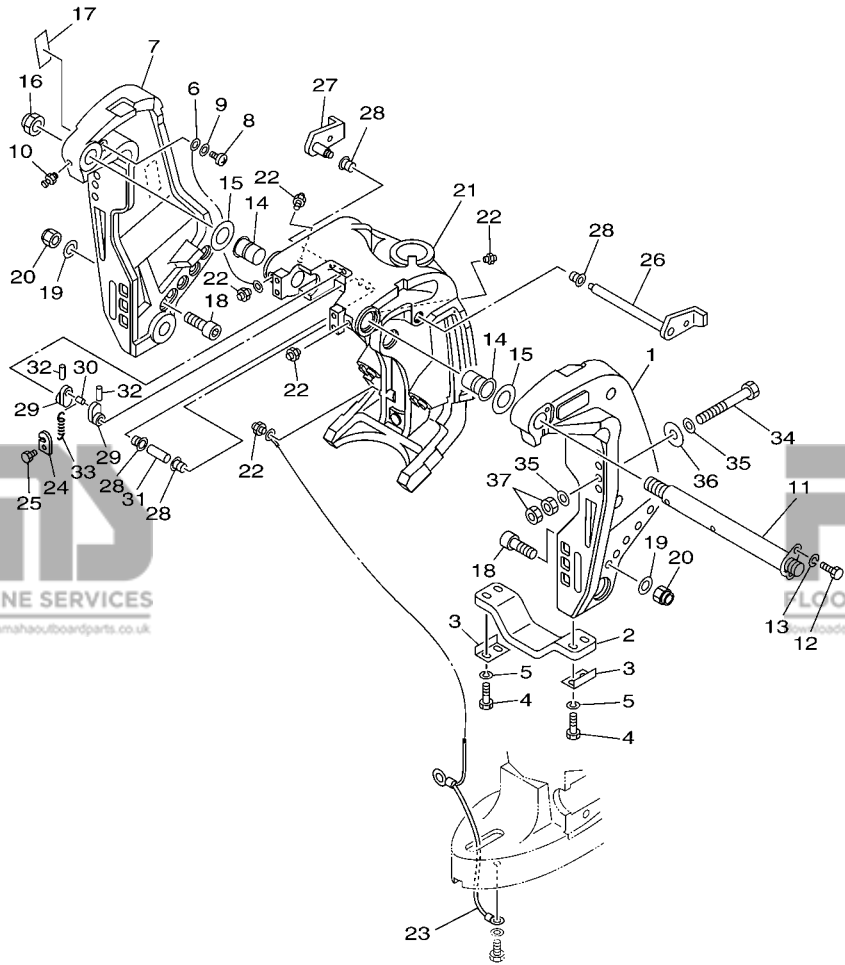

**FWD**  
6BC1200-F240

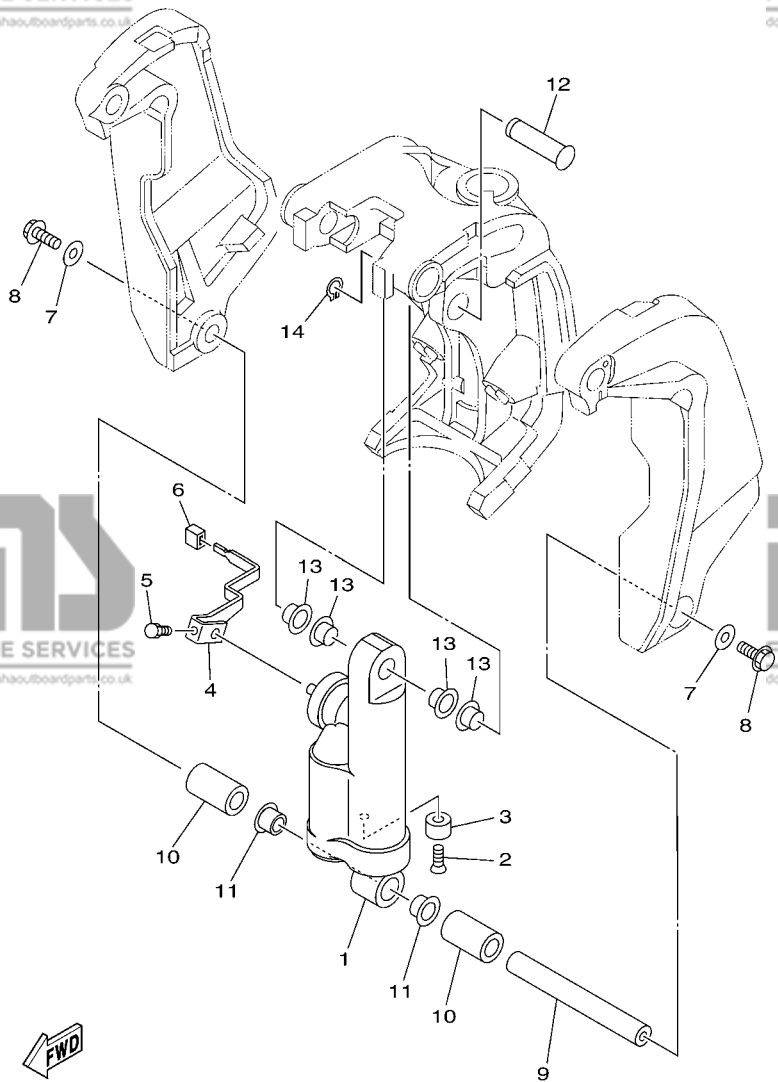

6BC3200-H250

**FIG. 21 BRACKET 2**

**SUPPORT 2**

REF. NO.	PART NO. N° PIECES	DESCRIPTION DESCRIPTION	6CK2	REMARKS REMARQUES
1	6BC-43107-00-8D	SHOCK ABSORBER SUB-ASSY AMORTISSEUR (ENS.)	1	
2	90152-06M01	SCREW, COUNTERSUNK VIS, TETE NOYEE	1	
3	663-45251-00	ANODE ANODE	1	
4	6BC-43631-00-8D	LEVER, TILT LEVIER, INCLINAISON	1	
5	90101-06057	BOLT BOULON	1	
6	6G1-43318-01	COVER CAPUCHON	1	
7	90201-10060	WASHER, PLATE RONDELLE, PLATE	2	
8	97575-10530	BOLT, WITH WASHER VIS HEXAGONAL AVC RONDELLE	2	
9	6BC-43818-00	PIN, LOWER SHOCK MOUNT AXE, INFERIEUR AMORTISSEUR	1	
10	90387-22018	COLLAR COLLERETTE	2	
11	90386-22M98	BUSH DOUILLE	2	
12	64E-43126-00	PIN, UPPER SHOCK MOUNT AXE, SUPERIEUR AMORTISSEUR	1	
13	90386-22M98	BUSH DOUILLE	4	
14	93410-22M11	CIRCLIP CLIPS	1	

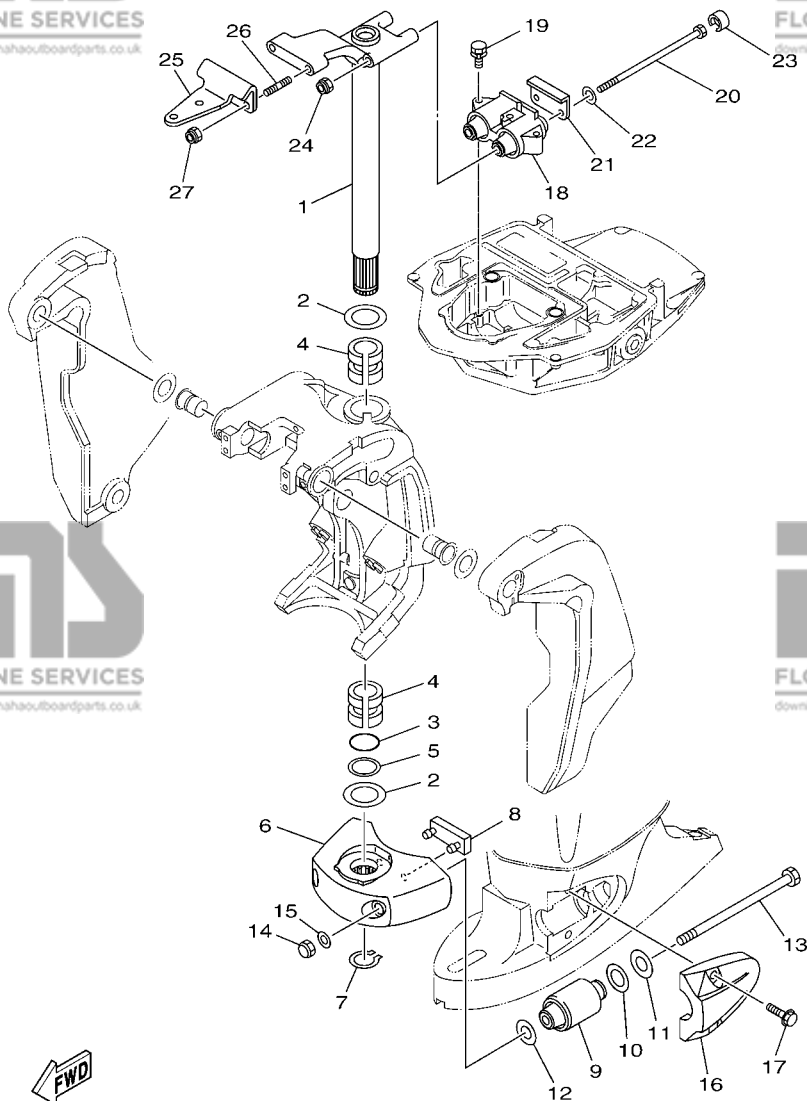

**FWD**  
6CK2300-J220

**FIG. 22 BRACKET 3**

**SUPPORT 3**

REF. NO.	PART NO. N° PIECES	DESCRIPTION DESCRIPTION	6CK2	REMARKS REMARQUES
1	68V-42510-10-8D	STEERING BRACKET ASSY DIRECTION SUPPORT (ENS.)	1	L(20.3") L(20.3")
2	90201-38M60	WASHER, PLATE RONDELLE, PLATE	2	
3	93210-37MH7	O-RING JOINT TORIQUE	1	
4	90386-38M32	BUSH DOUILLE	2	
5	90202-40M47	WASHER, PLATE RONDELLE, PLATE	1	
6	68V-44551-00-8D	HOUSING, LOWER MOUNT RUBBER BOITIER, SILENT-BLOC INFERIEUR	1	
7	93410-37M04	CIRCLIP CLIPS	1	
8	61A-44575-00	DAMPER, LOWER MOUNT RUBBER SILENT-BLOC, INFERIEUR	1	
9	61A-44555-01-94	MOUNT DAMPER, LOWER SIDE SILENT-BLOC, INFERIEUR LATERAL	2	
10	90202-32M19	WASHER, PLATE RONDELLE, PLATE	2	
11	90201-16M55	WASHER, PLATE RONDELLE, PLATE	2	
12	90201-15M58	WASHER, PLATE RONDELLE, PLATE	2	
13	90109-14007	BOLT BOULON	2	
14	95380-14600	NUT ECROU	2	
15	92995-14600	WASHER RONDELLE	2	
16	68V-44553-00-8D	COVER, LOWER MOUNT COUVERCLE, SUSPENSION INFERIEUR	2	
17	90119-10049	BOLT, WITH WASHER BOULON, AVEC RONDELLE	4	
18	67F-44514-01-94	MOUNT DAMPER, UPPER SIDE SILENT-BLOC, SUPERIEUR LATERAL	1	
19	90119-08091	BOLT, WITH WASHER BOULON, AVEC RONDELLE	3	
20	90109-12007	BOLT BOULON	2	
21	67F-44526-00	PLATE PLAQUE	1	
22	90201-12M09	WASHER, PLATE RONDELLE, PLATE	2	
23	67F-44533-00	DAMPER, UPPER MOUNT RUBBER COUVERCLE, SUSPENSION INFERIEUR	2	
24	90185-12M12	NUT, SELF-LOCKING ECROU, AUTO-BLOQUANT	2	
25	68V-48511-10	HOOK, STEERING ATTACHE, DIRECTION	1	
26	90116-10175	BOLT, STUD GOIJON	2	
27	90185-10051	NUT, SELF-LOCKING ECROU, AUTO-BLOQUANT	2	

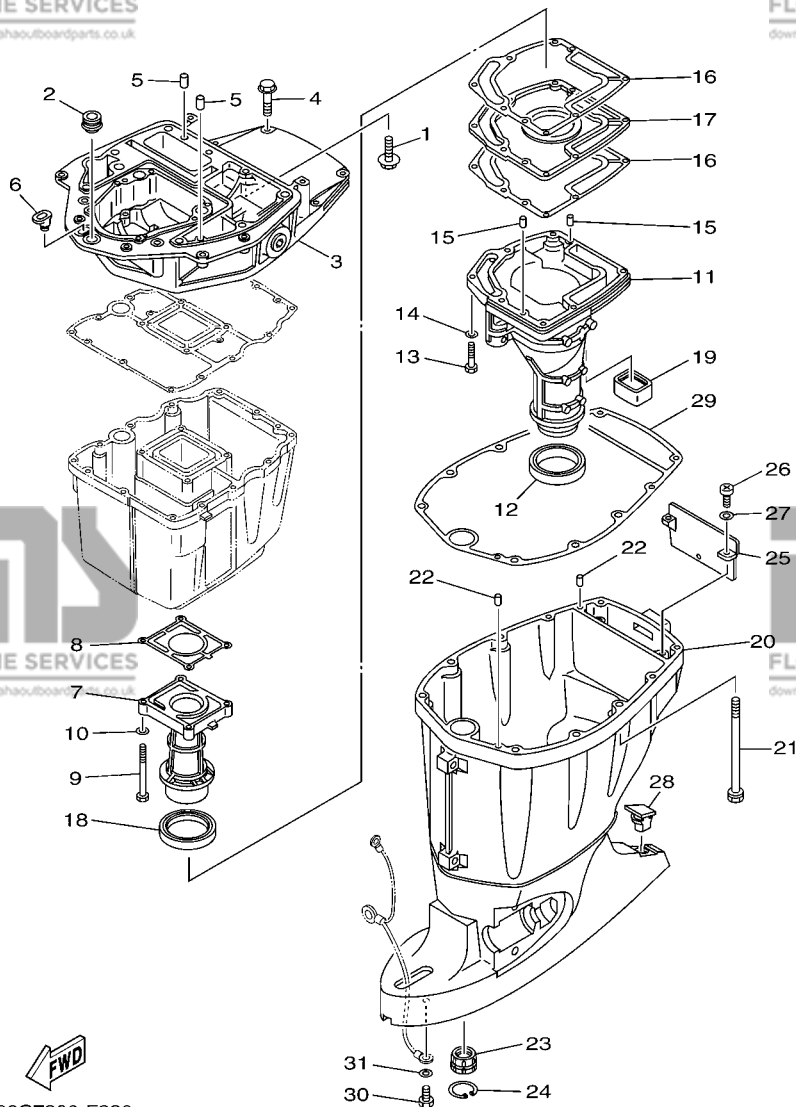

60C7300-F230

**FIG. 23 UPPER CASING**

**FOURREAU**

REF. NO.	PART NO. N° PIECES	DESCRIPTION DESCRIPTION	QTY	REMARKS REMARQUES
1	90119-08M58	BOLT, WITH WASHER BOULON, AVEC RONDELLE	2	
2	67F-42724-00	GROMMET PASSE-FIL	1	
3	67F-41137-02-CA	GUIDE, EXHAUST COLLECTEUR D'ECHAPPEMENT	1	
4	97575-08540	BOLT, WITH WASHER VIS HEXAGONAL AVEC RONDELLE	4	
5	93608-16M16	PIN, DOWEL AXE	2	
6	6G1-42727-00	GROMMET PASSE-FIL	1	
7	60C-41131-01-9S	MANIFOLD, EXT. 1 PIPE D'ECHAPPEMENT	1	
8	67F-41133-A1	GASKET, EXHAUST MANIFOLD 1 JOINT, PIPE D'ECHAPPEMENT	1	
9	97075-06070	BOLT BOULON	4	
10	92995-06600	WASHER RONDELLE	4	
11	60C-14711-10-9S	MUFFLER 1 POT D'ECHAPPEMENT 1	1	L(20.3") L(20.3")
12	68V-45123-00	GASKET, MUFFLER JOINT, POT DE DETENTE	1	
13	97075-06030	BOLT BOULON	7	
14	92995-06600	WASHER RONDELLE	7	
15	93606-19M23	PIN, DOWEL GOUILLE	2	
16	67F-41134-A0	GASKET, EXHAUST MANIFOLD JOINT, PIPE D'ECHAPPEMENT	2	
17	67F-45181-00-CA	PLATE PLAQUETTE	1	
18	67F-41138-00	SEAL, EXT. 1 JOINT DE GROUPE 1	1	
19	67F-45127-00	SEAL JOINT	1	
20	68V-45111-11-8D	CASING, UPPER FOURREAU	1	L(20.3") L(20.3")
21	90119-10M08	BOLT, WITH WASHER BOULON, AVEC RONDELLE	6	
22	93608-16M16	PIN, DOWEL AXE	2	
23	6E5-45318-00	BUSHING, DRIVE SHAFT DOUILLE, ARBRE MOTEUR	1	
24	93420-36M01	CIRCLIP CIRCLIP, TYPE S	1	
25	67F-45151-00	COVER, UPPER CASING CAPUCHON, FOURREAU	1	
26	97880-06016	SCREW, PAN HEAD VIS, TETE TRONCONIQUE	2	
27	92990-06600	WASHER, PLATE RONDELLE, PLATE	2	

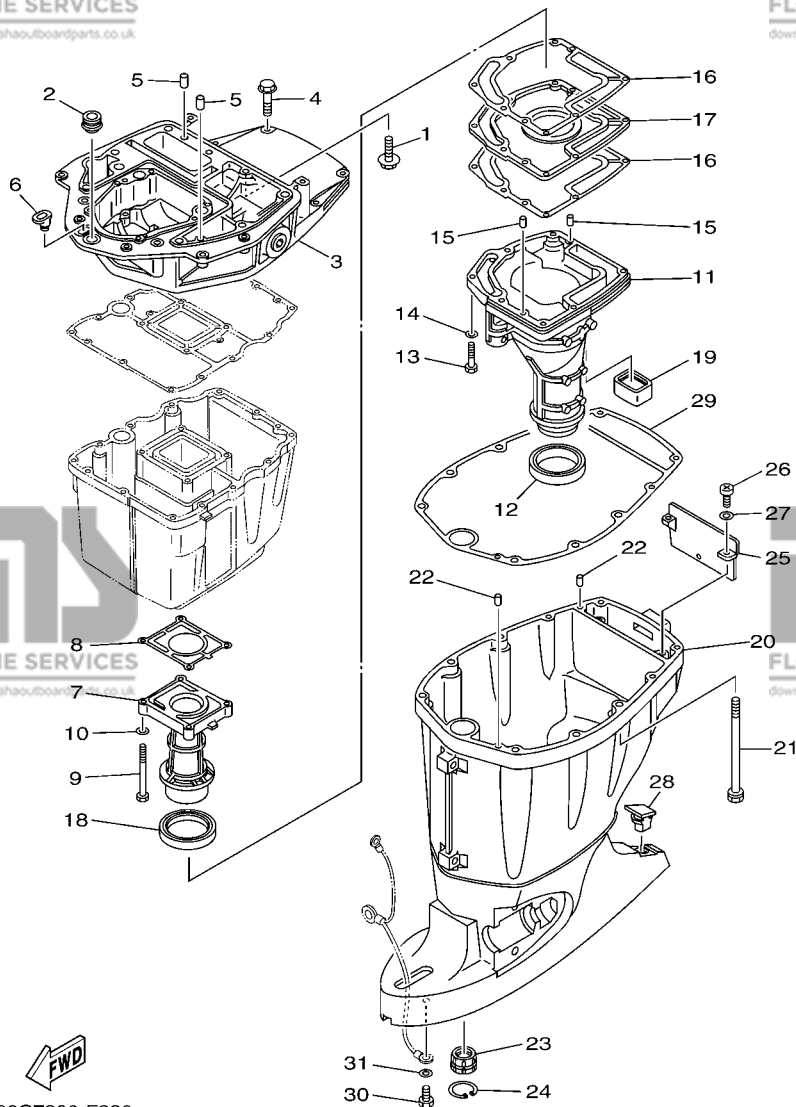

60C7300-F230

**FIG. 23 UPPER CASING**

**FOURREAU**

REF. NO.	PART NO. N° PIECES	DESCRIPTION DESCRIPTION	60K2	REMARKS REMARQUES
28	6C5-45155-00	CAP CAPUCHON	1	
29	67F-45113-00	GASKET, UPPER CASING JOINT, TUBE D'ARBRE	1	
30	97095-06010	BOLT BOULON	1	
31	92995-06600	WASHER RONDELLE	1	

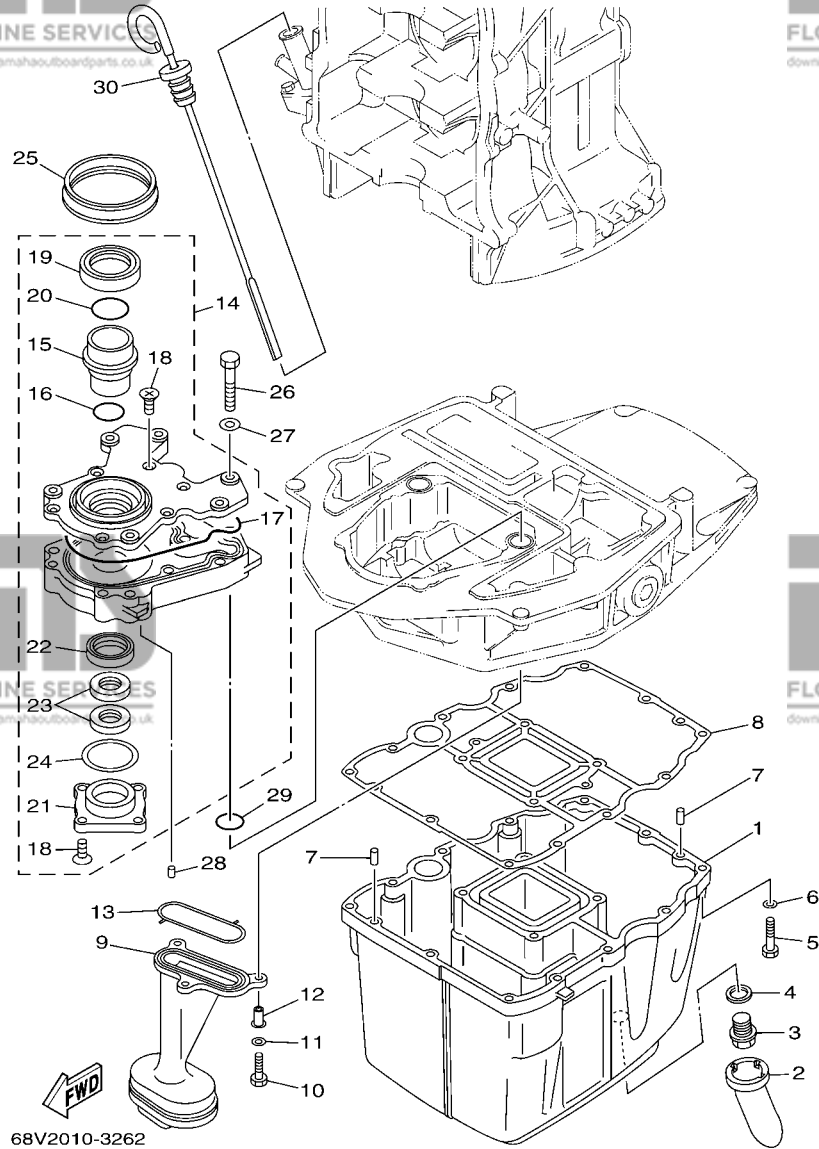
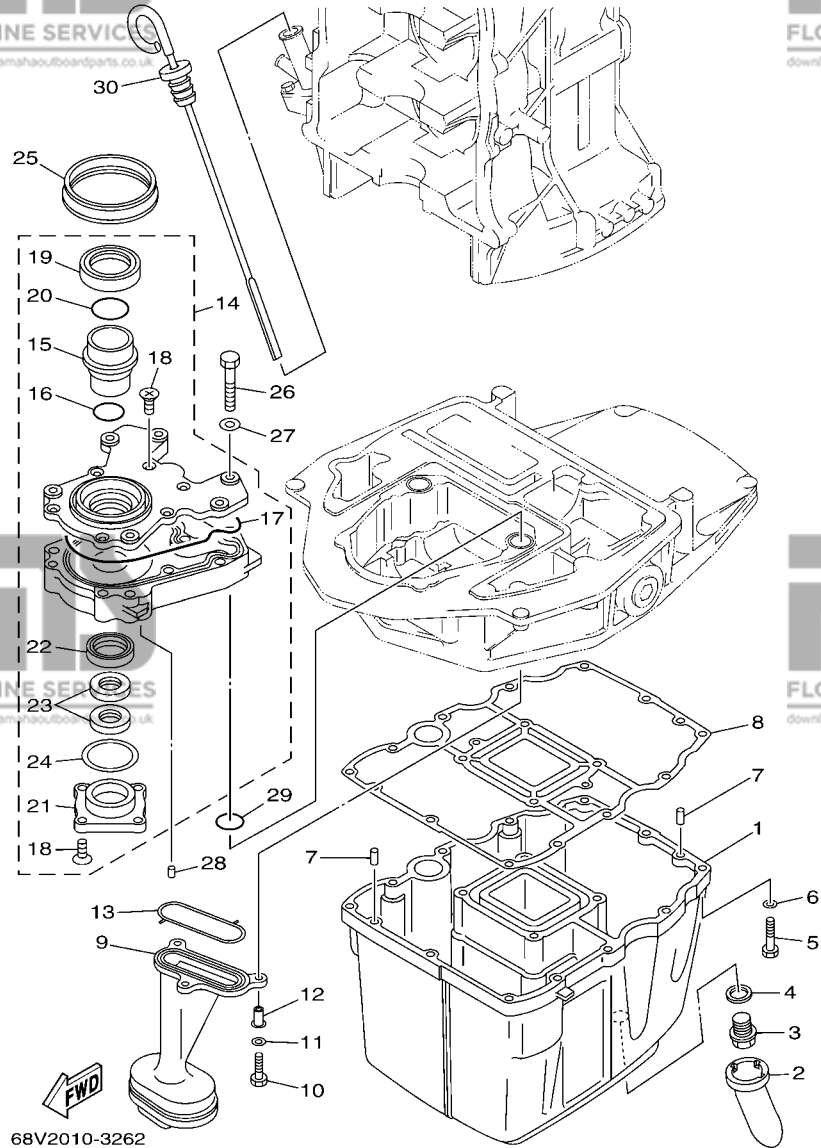

**FIG. 24 OIL PAN**

**VENTILATEUR D'HUILE**

REF. NO.	PART NO. N° PIECES	DESCRIPTION DESCRIPTION	QTY	60K2	REMARKS REMARQUES
1	68V-15311-00-CA	OIL PAN VENTILATEUR D'HUILE	1		
2	63P-15316-00	DAMPER 1 AMORTISSEUR 1	1		
3	90340-14M06	PLUG, STRAIGHT SCREW PLOT, FILETE DROIT	1		
4	90430-14M09	GASKET JOINT	1		
5	97075-06025	BOLT BOULON	12		
6	92995-06600	WASHER RONDELLE	12		
7	93606-12019	PIN, DOWEL GOUILLE	2		
8	68V-15312-00	GASKET, OIL PAN JOINT DE VENTILATEUR D'HUILE	1		
9	67F-13411-00	STRAINER, OIL FILTRE, HUILE	1		
10	97027-06025	BOLT, HEXAGON BOULON	3		
11	92907-06600	WASHER, PLATE RONDELLE	3		
12	90387-06M64	COLLAR COLLERETTE	3		
13	67F-13415-00	SEAL, OIL STRAINER JOINT, FILTRE A HUILE	1		
14	67F-13300-10	OIL PUMP ASSY POMPE A HUILE COMPLETE	1		
15	67F-13314-02	.SHAFT, PUMP .AXE DE POMPE	1		
16	67F-13473-01	.O-RING .JOINT TORIQUE	1		
17	67F-13329-00	.GASKET, PUMP COVER .JOINT, COUVERCLE DE POMPE	1		
18	67F-13495-00	.SCREW .VIS	10		
19	67F-13119-01	.OIL SEAL .JOINT SPY	1		
20	67F-13769-00	.O-RING .JOINT TORIQUE	1		
21	67F-13914-00	.HOUSING, PUMP .CORPS, POMPE	1		
22	67F-13631-03	.OIL SEAL .JOINT SPY	1		
23	67F-13149-00	.OIL SEAL .JOINT SPY	2		
24	67F-13339-00	.GASKET, PUMP COVER .BAIN, COUVERCLE DE POME	1		
25	67F-13338-00	SEAL JOINT	1		
26	97095-06045	BOLT BOULON	6		
27	92995-06600	WASHER RONDELLE	6		





**FIG. 24 OIL PAN**

**VENTILATEUR D'HUILE**

REF. NO.	PART NO. N° PIECES	DESCRIPTION DESCRIPTION	60K2	REMARKS REMARQUES
28	93604-12M07	PIN, DOWEL CLAVETTE	2	
29	93210-19MJ1	O-RING JOINT TORIQUE	2	
30	6D8-15362-00	PLUG, OIL LEVEL PLOT, NIVEAU D'HUILE	1	
-----				
-----				
-----				
-----				
-----				
-----				
-----				
-----				
-----				
-----				

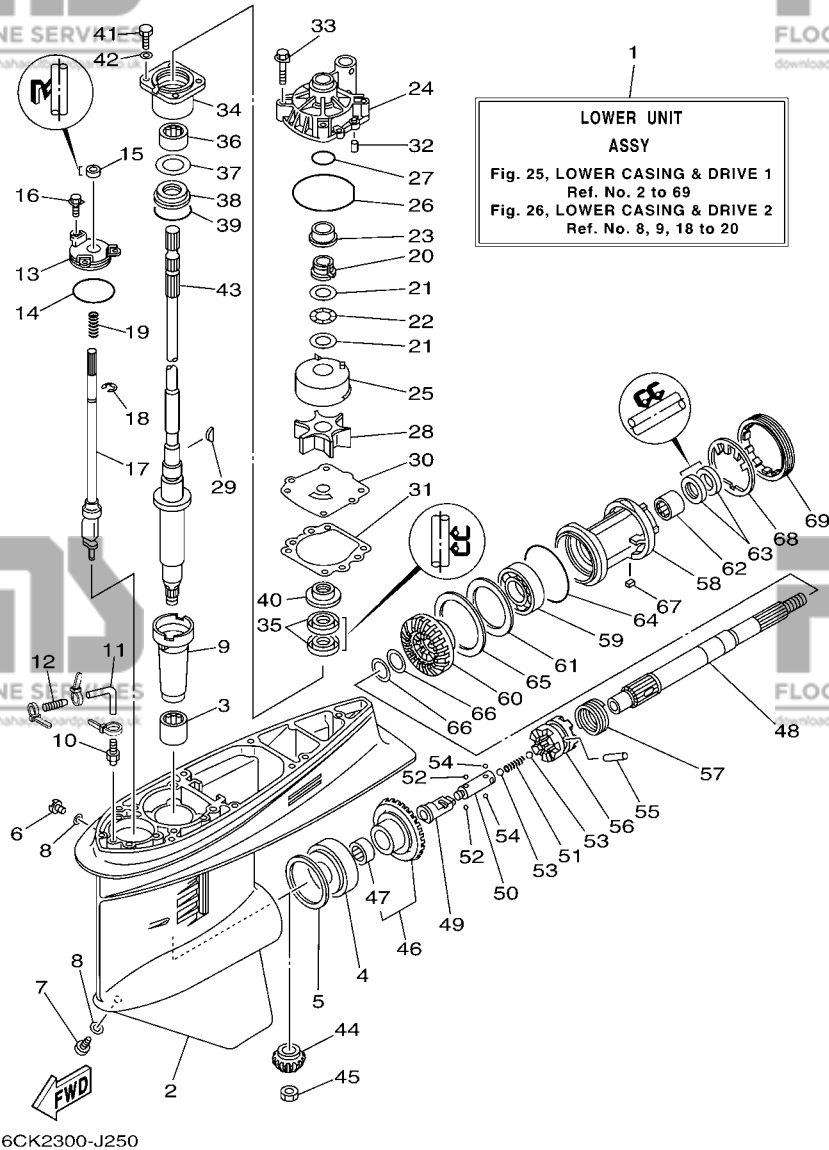

FIG. 25 LOWER CASING & DRIVE 1

BOITIER D'HELICE TRANSMISSION1

REF. NO.	PART NO. N° PIECES	DESCRIPTION DESCRIPTION	6CK2	REMARKS REMARQUES
1	60C-45300-11-8D	LOWER UNIT ASSY UNITE INFERIEURE (ENS.)	1	L(20.3") L(20.3")
2	6E5-45301-05-8D	CASING, LOWER BEQUILLE	1	
3	93315-628U9	BEARING ROULEMENT	1	
4	93332-000U7	BEARING ROULEMENT	1	
5	6E5-45567-01	SHIM (T:0.10MM) CALE (T:0.10MM)	1	UR UR
6E5-45567-10	SHIM (T:0.12MM) CALE (T:0.12MM)	1	UR UR	
6E5-45567-20	SHIM (T:0.15MM) CALE (T:0.15MM)	1	UR UR	
6E5-45567-30	SHIM (T:0.18MM) CALE (T:0.18MM)	1	UR UR	
6E5-45567-40	SHIM (T:0.30MM) CALE (T:0.30MM)	1	UR UR	
6E5-45567-50	SHIM (T:0.40MM) CALE (T:0.40MM)	1	UR UR	
6E5-45567-60	SHIM (T:0.50MM) CALE (T:0.50MM)	1	UR UR	
6	90340-08002	PLUG, STRAIGHT SCREW PLOT, FILETE DROIT	1	
7	688-45341-10	PLUG, DRAIN BOUCHON DE VIDANGE	1	
8	90430-08020	GASKET JOINT	2	
9	6E5-45536-00	SLEEVE, DRIVE SHAFT MANCHON, ARBRE MOTEUR	1	
10	6E5-45378-00	NIPPLE, HOSE RACCORD, TUYAU	1	
11	90445-07ME8	HOSE (L80) DURITE (L80)	1	L(20.3") L(20.3")
12	6E5-83558-10	END, NIPPLE RACCORD DE NIPPLE	1	
13	6E5-45321-00	PLATE PLAQUETTE	1	
14	93210-58144	O-RING JOINT TORIQUE	1	
15	93106-09014	OIL SEAL JOINT SPY	1	
16	90119-06M10	BOLT, WITH WASHER BOULON, AVEC RONDELLE	3	
17	6L6-44150-01	SHIFT CAM ASSY CAME D'INVERSION	1	
18	99001-08600	CIRCLIP CIRCLIP	1	
19	90501-11M10	SPRING, COMPRESSION RESSORT, COMPRESSION	1	
20	61A-45538-00	SPACER 1 ENTRETOISE	1	
21	90201-22M01	WASHER, PLATE RONDELLE, PLATE	2	

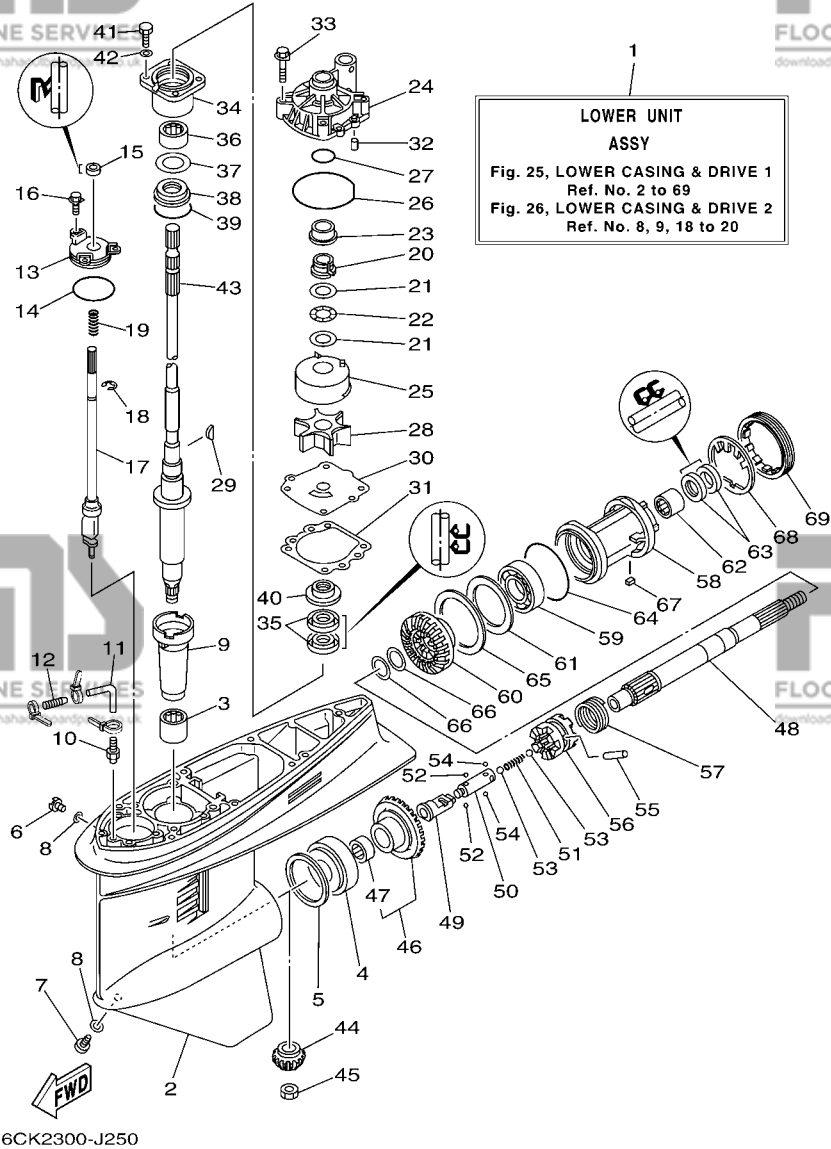

FIG. 25 LOWER CASING & DRIVE 1

BOITIER D'HELICE TRANSMISSION1

REF. NO.	PART NO. N° PIECES	DESCRIPTION DESCRIPTION	6CK2	REMARKS REMARQUES
22	90206-22M19	WASHER, WAVE RONDELLE, ONDULEE	1	
23	61A-45527-00	COLLAR, DRIVE SHAFT ENTRETOISE	1	
24	61A-44311-01	HOUSING, WATER PUMP CORPS, POMPE A EAU	1	
25	6R3-44322-42	INSERT, CARTRIDGE CUVETTE	1	FOR CHROMATE FOR CHROMATE
26	93210-86M38	O-RING JOINT TORIQUE	1	
27	93210-37160	O-RING JOINT TORIQUE	1	
28	6E5-44352-01	IMPELLER TURBINE	1	
29	90280-04M05	KEY, WOODRUFF CLAVETTE, DEMI-LUNE	1	
30	60C-44323-40	OUTER PLATE, CARTRIDGE PLAQUE EXTERIEURE	1	FOR CHROMATE FOR CHROMATE
31	6E5-44315-A0	GASKET, WATER PUMP JOINT, POMPE A EAU	1	
32	93606-12019	PIN, DOWEL GOUPILLE	2	
33	90119-08M14	BOLT, WITH WASHER BOULON, AVEC RONDELLE	4	
34	6E5-45331-00-9S	HOUSING, BEARING FLASQUE, ROULEMENT	1	
35	93101-28M16	OIL SEAL JOINT SPY	2	
36	93317-330U2	BEARING ROULEMENT	1	
37	6E5-45587-01	SHIM (T:0.10MM) CALE (T:0.10MM)	1	UR
	6E5-45587-10	SHIM (T:0.12MM) CALE (T:0.12MM)	1	UR
	6E5-45587-20	SHIM (T:0.15MM) CALE (T:0.15MM)	1	UR
	6E5-45587-30	SHIM (T:0.18MM) CALE (T:0.18MM)	1	UR
	6E5-45587-40	SHIM (T:0.30MM) CALE (T:0.30MM)	1	UR
	6E5-45587-50	SHIM (T:0.40MM) CALE (T:0.40MM)	1	UR
	6E5-45587-60	SHIM (T:0.50MM) CALE (T:0.50MM)	1	UR
38	93341-930V2	BEARING CERVEAUX DE DIRECTION	1	
39	93210-55M14	O-RING JOINT TORIQUE	1	
40	6E5-45344-00	COVER, OIL SEAL FLASQUE, JOINT D'HUILE	1	
41	97095-08025	BOLT BOULON	4	
42	92995-08600	WASHER RONDELLE	4	

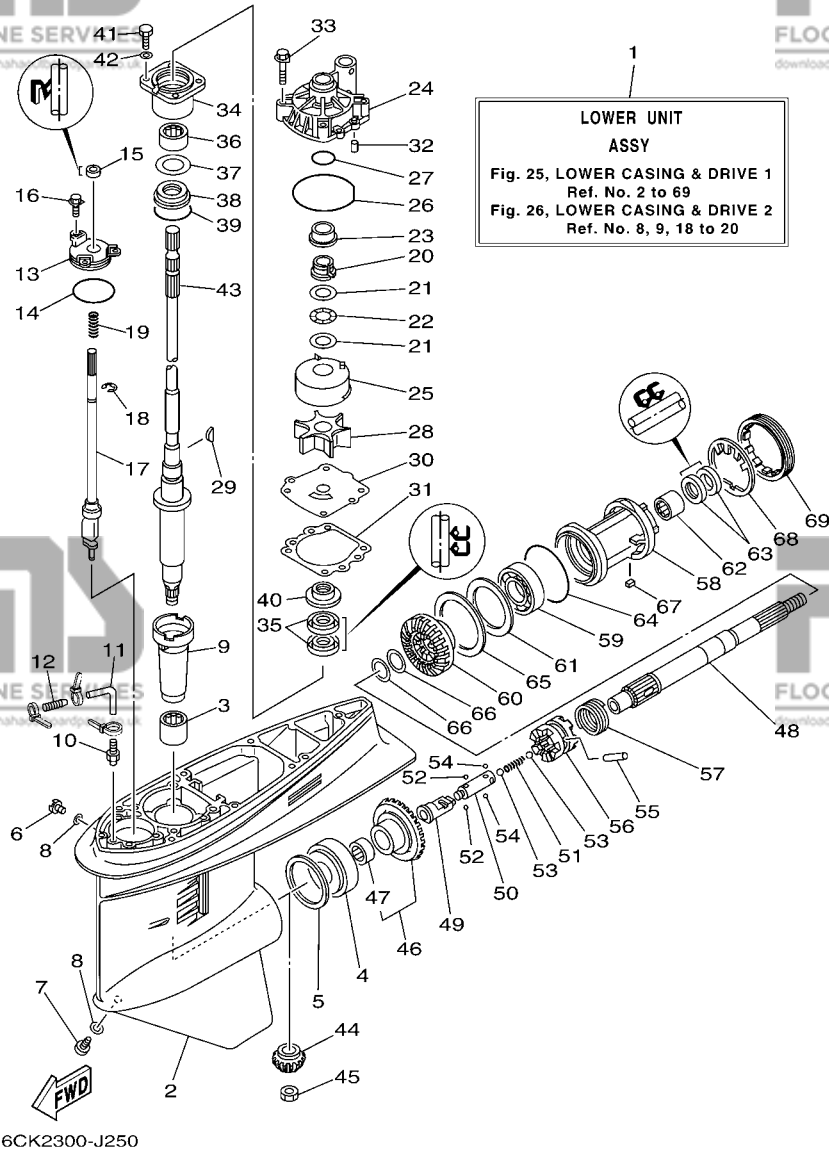

FIG. 25 LOWER CASING & DRIVE 1

BOITIER D'HELICE TRANSMISSION1

REF. NO.	PART NO. N° PIECES	DESCRIPTION DESCRIPTION	6CK2	REMARKS REMARQUES
43	68V-45501-10	DRIVE SHAFT COMP. ARBRE MOTEUR COMP.	1	L(20.3") L(20.3")
44	68V-45551-00	PINION (13T) PIGNON D'ATTAQUE (13D)	1	
45	90170-16M01	NUT ECROU	1	
46	68V-45560-00	GEAR 1 (28T) PIGNON 1 (28T)	1	
47	93315-425U7	.BEARING .ROULEMENT	1	
48	6E5-45611-01	SHAFT, PROPELLER ARBRE, HELICE	1	
49	6K1-45641-01	SHIFTER EMBRAYAGE	1	
50	6E5-45634-01	SLIDE, SHIFT CONTRE-POUSSOIR	1	
51	90501-16M37	SPRING, COMPRESSION RESSORT, COMPRESSION	1	
52	93507-32009	BALL BILLE	2	
53	93511-32017	BALL BILLES	2	
54	93503-16003	BALL BILLES	2	
55	90250-08M07	PIN, STRAIGHT GOUPILLE, DROITE	1	
56	68V-45631-01	CLUTCH, DOG CRABOT	1	
57	6E5-45633-01	RING, CROSS PIN JONC, GOUPILLE CRABOT	1	
58	6E5-45332-00-CA	HOUSING, BEARING FLASQUE, ROULEMENT	1	
59	93306-208U0	BEARING ROULEMENT	1	
60	68V-45571-00	GEAR 2 (28T) PIGNON 2 (28T)	1	
61	6E5-45576-00	WASHER, THRUST RONDELLE DE CALAGE	1	
62	93315-430U8	BEARING ROULEMENT	1	
63	93101-30M17	OIL SEAL JOINT SPY	2	
64	93210-86M39	O-RING JOINT TORIQUE	1	
65	6L6-45577-00	SHIM (T:0.10MM) CALE (T:0.10MM)	1	UR
	6L6-45577-10	SHIM (T:0.12MM) CALE (T:0.12MM)	1	UR
	6L6-45577-20	SHIM (T:0.15MM) CALE (T:0.15MM)	1	UR
	6L6-45577-30	SHIM (T:0.18MM) CALE (T:0.18MM)	1	UR
	6L6-45577-40	SHIM (T:0.30MM) CALE (T:0.30MM)	1	UR

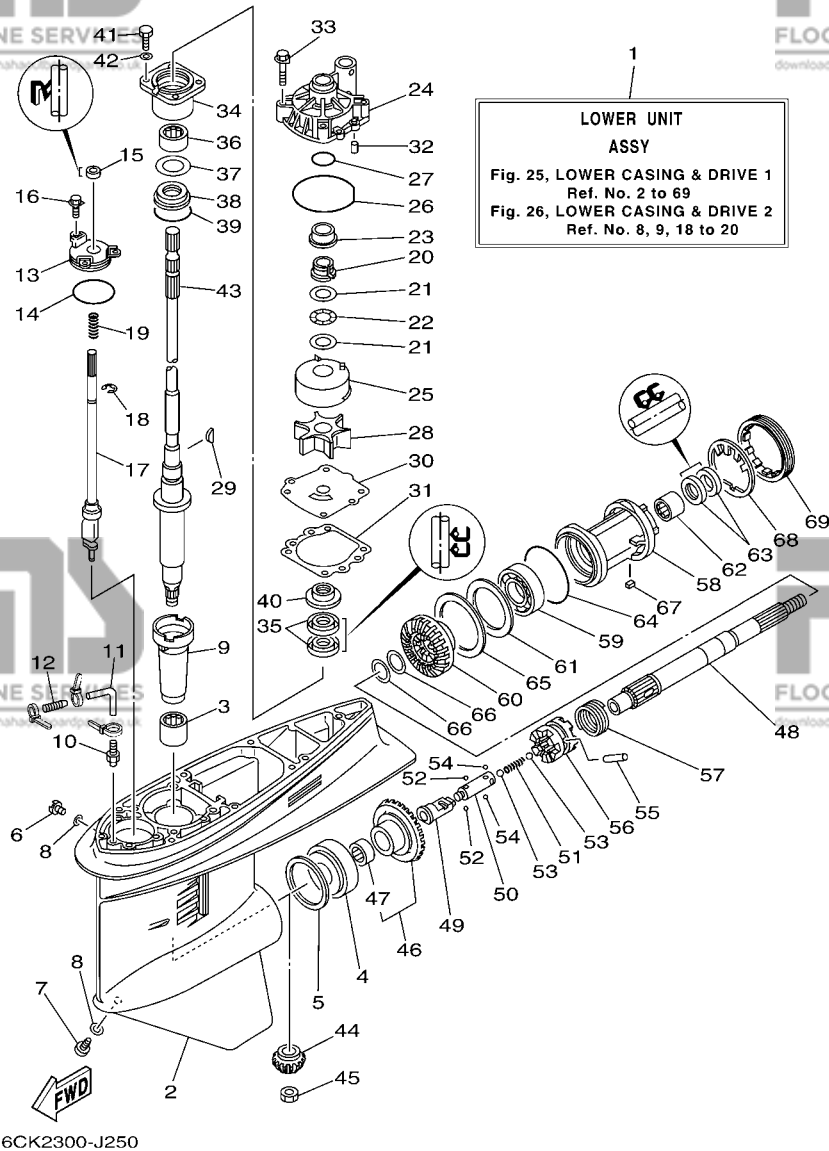
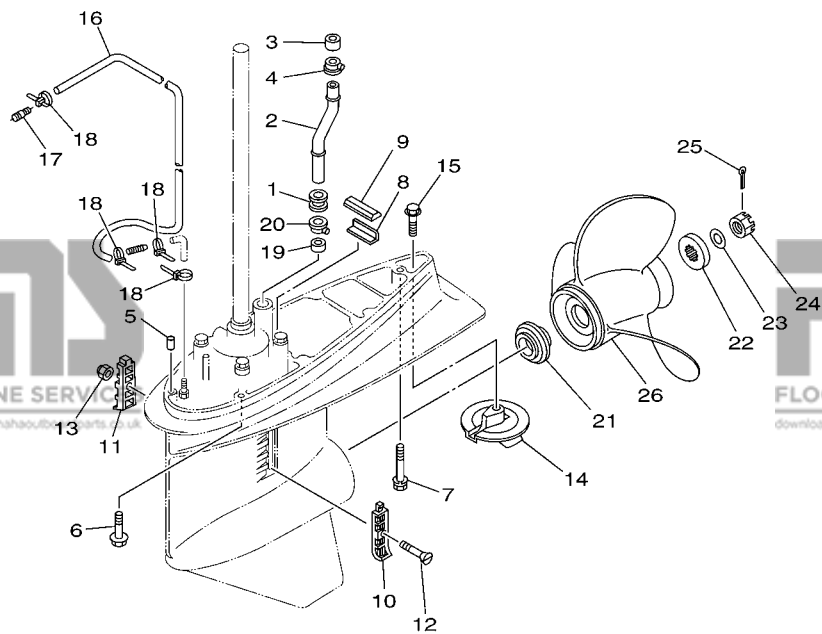

FIG. 25 LOWER CASING & DRIVE 1

BOITIER D'HELICE TRANSMISSION1

REF. NO.	PART NO. N° PIECES	DESCRIPTION DESCRIPTION	6CK2	REMARKS REMARQUES
65	6L6-45577-50	SHIM (T:0.40MM) CALE (T:0.40MM)	1	UR
66	6L6-45577-60	SHIM (T:0.50MM) CALE (T:0.50MM)	1	UR
66	90201-30M92	WASHER, PLATE RONDELLE, PLATE	2	UR
67	90282-04010	KEY, STRAIGHT CLAVETTE, DROITE	1	
68	688-45383-02	WASHER, CLAW FREIN D'ECROU	1	
69	688-45384-00	NUT ECROU	1	

**FIG. 26 LOWER CASING & DRIVE 2 BOITIER D'HELICE TRANSMISSION2**



6CK2300-J260

REF. NO.	PART NO. N° PIECES	DESCRIPTION DESCRIPTION	6CK2	REMARKS REMARQUES
1	6E5-44366-00	DAMPER, WATER SEAL JOINT, TUBE D'EAU	1	
2	6BC-44361-10	TUBE, WATER TUBE D'EAU	1	L(20.3") L(20.3")
3	6E5-44365-00	DAMPER, WATER SEAL JOINT, TUBE D'EAU	1	
4	6E5-44312-00	COVER, WATER PUMP HOUSING COUVERCLE	1	
5	93608-12M05	PIN, DOWEL AXE	2	
6	90119-10053	BOLT, WITH WASHER BOULON, AVEC RONDELLE	6	
7	90119-10M89	BOLT, WITH WASHER BOULON, AVEC RONDELLE	1	
8	663-45376-00-94	GUIDE, SEAL DAMPER BUTEE, JOINT CAOUTCHOUC	1	
9	688-45375-00	DAMPER, SEAL BOURRELET, CAOUTCHOUC	1	
10	688-45214-02	COVER, WATER INLET 1 GRILLE, ENTREE D'EAU 1	1	
11	688-45215-02	COVER, WATER INLET 2 GRILLE, ENTREE D'EAU 2	1	
12	90152-05M07	SCREW, COUNTERSUNK VIS, TETE NOYEE	1	
13	90185-05002	NUT, NYLON ECROU, AUTO-BLOQUANT	1	
14	6E5-45371-01	TAB-TRIM ANODE DERIVE	1	
15	90105-10M00	BOLT, FLANGE BOULON	1	
16	90445-076K2	HOSE (L1550) DURITE (L1550)	1	
17	6E5-83558-00	END, NIPPLE RACCORD DE NIPPLE	1	
18	90465-11M10	CLAMP BRIDE	4	
19	6E5-44365-00	DAMPER, WATER SEAL JOINT, TUBE D'EAU	1	
20	6E5-44312-00	COVER, WATER PUMP HOUSING COUVERCLE	1	
21	63P-45987-00	SPACER ENTRETOISE	1	
22	688-45997-01	SPACER ENTRETOISE	1	
23	92990-18200	WASHER RONDELLE, PLATE	1	
24	90171-18M04	NUT, CASTLE ECROU, CRENELE	1	
25	91490-40030	PIN, COTTER GOUPILLE	1	
26	6E5-45941-00-EL	PROPELLER (3X13"X19"-K) HELICE (3X13"X19"-K)	1	UR
	6E5-45943-00-EL	PROPELLER (3X12-5/8"X21"-K) HELICE (3X12-5/8"X21"-K)	1	UR

**FIG. 26 LOWER CASING & DRIVE 2**

**BOITIER D'HELICE TRANSMISSION2**

REF. NO.	PART NO. N° PIECES	DESCRIPTION DESCRIPTION	6CK2	REMARKS REMARQUES
26	6E5-45945-01-EL	PROPELLER (3X13-1/4"X17"-K) HELICE (3X13-1/4"X17"-K)	1	UR UR
	6E5-45947-00-EL	PROPELLER (3X13-1/2"X15"-K) HELICE (3X13-1/2"X15"-K)	1	UR UR
	6E5-45949-00-EL	PROPELLER (3X13-5/8"X13"-K) HELICE (3X13-5/8"X13"-K)	1	UR UR
	6E5-45952-00-EL	PROPELLER (3X13"X23"-K) HELICE (3X13"X23"-K)	1	UR UR
	6E5-45954-00-EL	PROPELLER (3X14"X11"-K) HELICE (3X14"X11"-K)	1	UR UR
	6E5-45956-00-EL	PROPELLER (3X13"X25"-K) HELICE (3X13"X25"-K)	1	UR UR
	688-45930-02-98	PROPELLER (3X13"X17"-K) HELICE (3X13"X17"-K)	1	UR UR
	688-45932-60-98	PROPELLER (3X13-1/2"X14"-K) HELICE (3X13-1/2"X14"-K)	1	UR UR
	688-45970-03-98	PROPELLER (3X13"X19"-K) HELICE (3X13"X19"-K)	1	UR UR
	688-45972-02-98	PROPELLER (3X13"X21"-K) HELICE (3X13"X21"-K)	1	UR UR
	688-45974-02-98	PROPELLER (3X13"X23"-K) HELICE (3X13"X23"-K)	1	UR UR
	688-45976-01-98	PROPELLER (3X13"X25"-K) HELICE (3X13"X25"-K)	1	UR UR
	688-45978-60-98	PROPELLER (3X13-1/2"X16"-K) HELICE (3X13-1/2"X16"-K)	1	UR UR

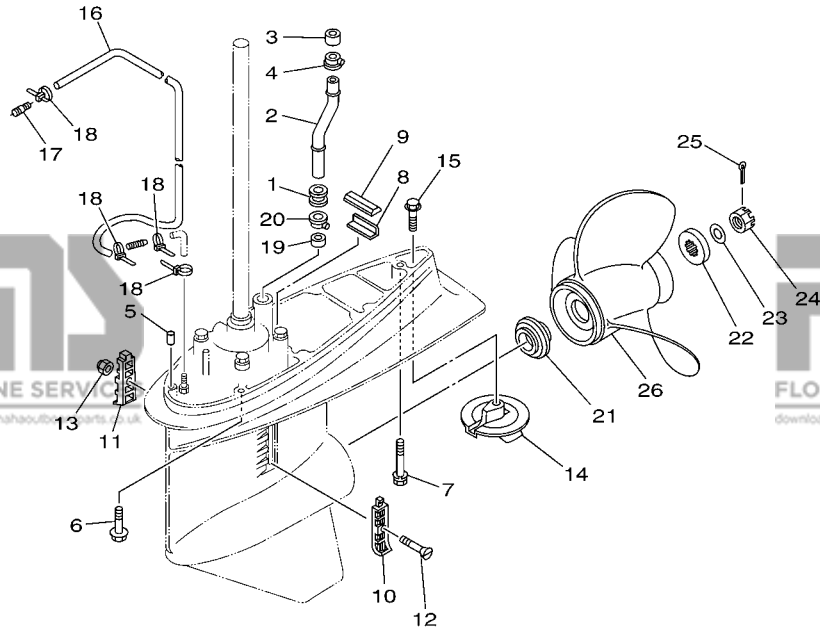

**FWD**  
6CK2300-J260

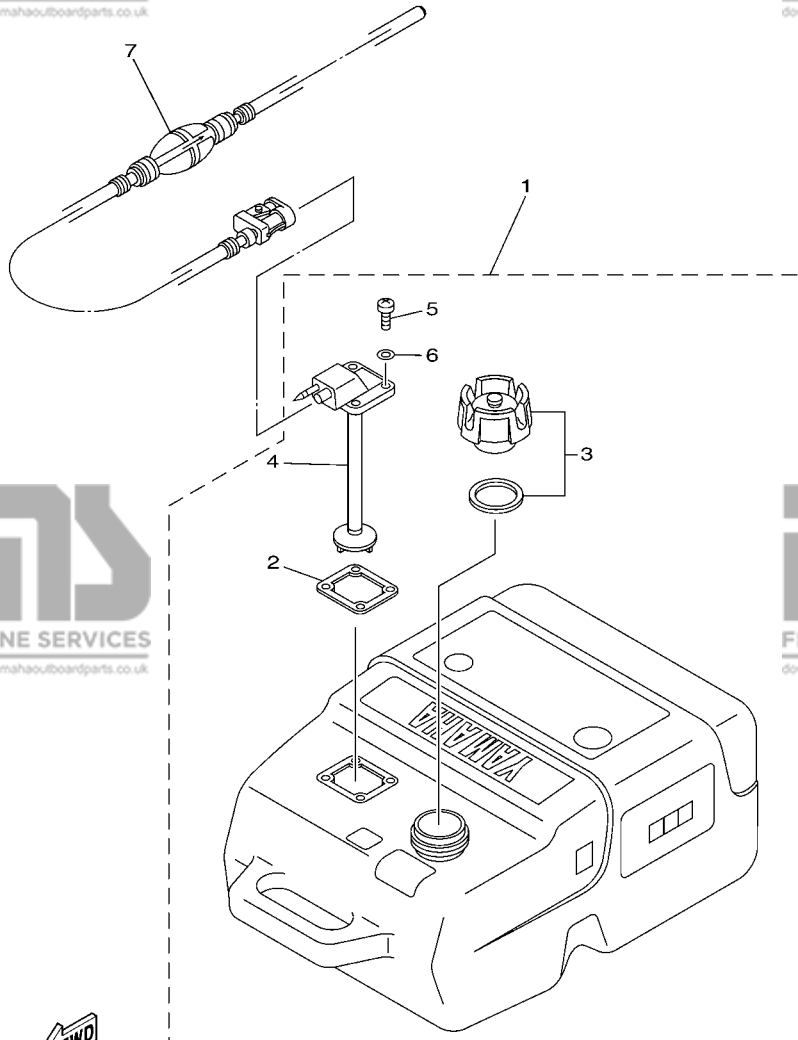

6D71300-D320

**FIG. 27 FUEL TANK**

**RESERVOIR A CARBURANT**

REF. NO.	PART NO. N° PIECES	DESCRIPTION DESCRIPTION	6CK2	REMARKS REMARQUES
1	6YK-24201-03	FUEL TANK ASSY (25L) RESERVOIR A ESSENCE (ENS.) 25L	1	AP AP
2	6YL-24268-01	.GASKET, FUEL METER .JOINT, JAUGE A CARBURANT	1	
3	6YK-24610-01	.CAP ASSY .BOUCHON	1	
4	6YK-24260-01	.FUEL METER ASSY .INDICATEUR DE CARBURANT	1	
5	90157-05M16	.SCREW, PAN HEAD .VIS, TETE TRONCONIQUE	4	
6	6YL-24329-00	.SEAL .JOINT	4	
7	6YK-24306-44	FUEL PIPE COMP. 1 DURITE A ESSENCE 1	1	AP AP



**FIG. 28 STEERING GUIDE**

**FIXATION DE DIRECTION**

REF. NO.	PART NO. N° PIECES	DESCRIPTION DESCRIPTION	QTY	REMARKS REMARQUES
1	6E5-61350-02	STEERING GUIDE ATTACHMENT KIT FIXATIONS DE DIRECTION	1	AP
2	6E5-61351-01	.ROD, STEERING LINK .RENOI DE DIRECTION	1	AP
3	90387-10M61	.COLLAR .COLLERETTE	1	
4	90560-12M01	.SPACER .ENTRETOISE	1	
5	6E5-61355-00	.BOLT .BOULON	1	
6	90185-09M01	.NUT, SELF-LOCKING .ECROU, AUTO-BLOQUANT	2	
7	90201-10M20	.WASHER, PLATE .RONDELLE, PLATE	2	
8	6E5-43145-01	.CAP CLAMP BRACKET .CAPUCHON, PRESSE	1	
9	93210-16275	.O-RING .JOINT TORIQUE	1	

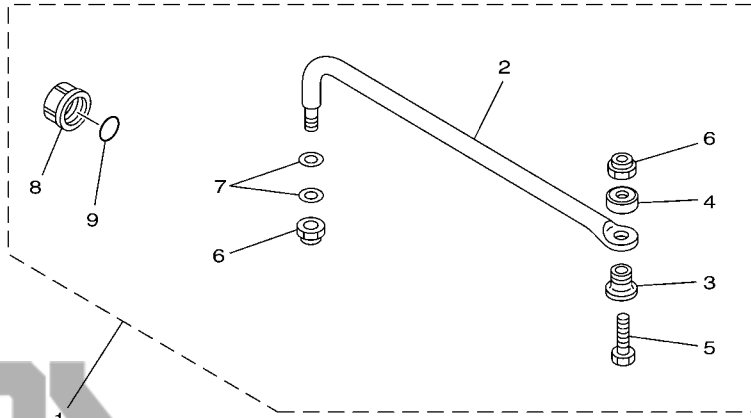

67H0100-9290

POWER HEAD  
GASKET KIT

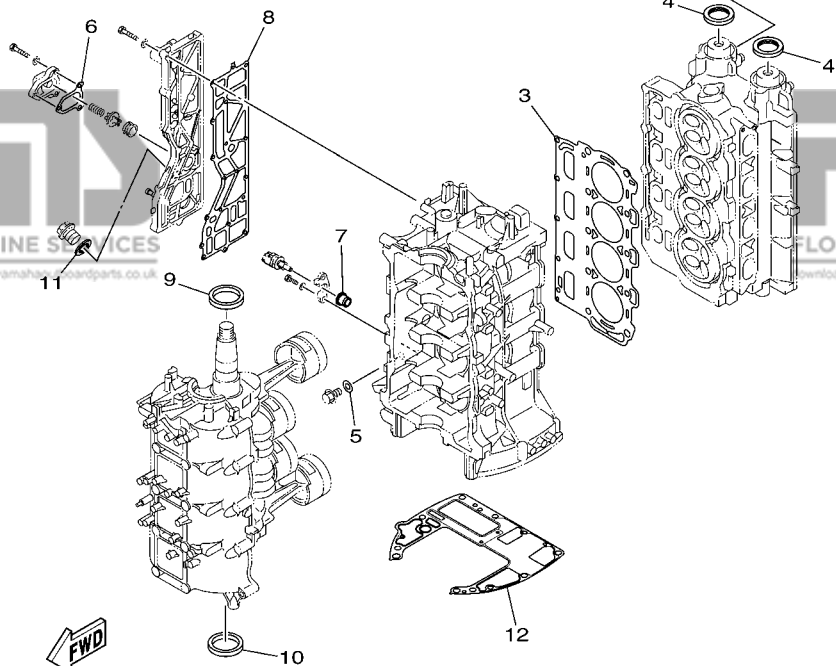
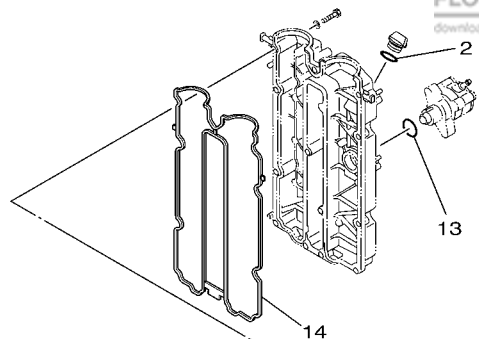

6BC1200-F360



FIG. 29 REPAIR KIT 1

KITS DE REPARATION 1

REF. NO.	PART NO. N° PIECES	DESCRIPTION DESCRIPTION	6CK2	REMARKS REMARQUES
1	6D8-W0001-02	POWER HEAD GASKET KIT POCHETTE DE JINTS TETE MOTRICE	1	
2	93210-24M79	.O-RING .JOINT TORIQUE	1	
3	67F-11181-03	.GASKET, CYLINDER HEAD 1 .JOINT, DE CULASSE 1	1	
4	93102-38008	.OIL SEAL .JOINT SPY	2	
5	90430-14115	.GASKET .JOINT	1	
6	67F-12435-A0	.GASKET .JOINT	1	
7	68V-85753-00	.GASKET, SENDER UNIT .JOINT, DE PERCEPTION	1	
8	67F-41114-A2	.GASKET, EXHAUST OUTER COVER .JOINT, COUVERCLE D'ECHAPPEMENT	1	
9	93102-48008	.OIL SEAL .JOINT SPY	1	
10	93101-48001	.OIL SEAL .JOINT SPY	1	
11	90430-18130	.GASKET .JOINT	1	
12	68V-11351-00	.GASKET, CYLINDER .JOINT, D'EMBASE	1	
13	93210-30682	.O-RING .JOINT TORIQUE	1	
14	6D8-11356-01	.SEAL, CYLINDER 2 .JOINT, SPY CYLINDRE	1	

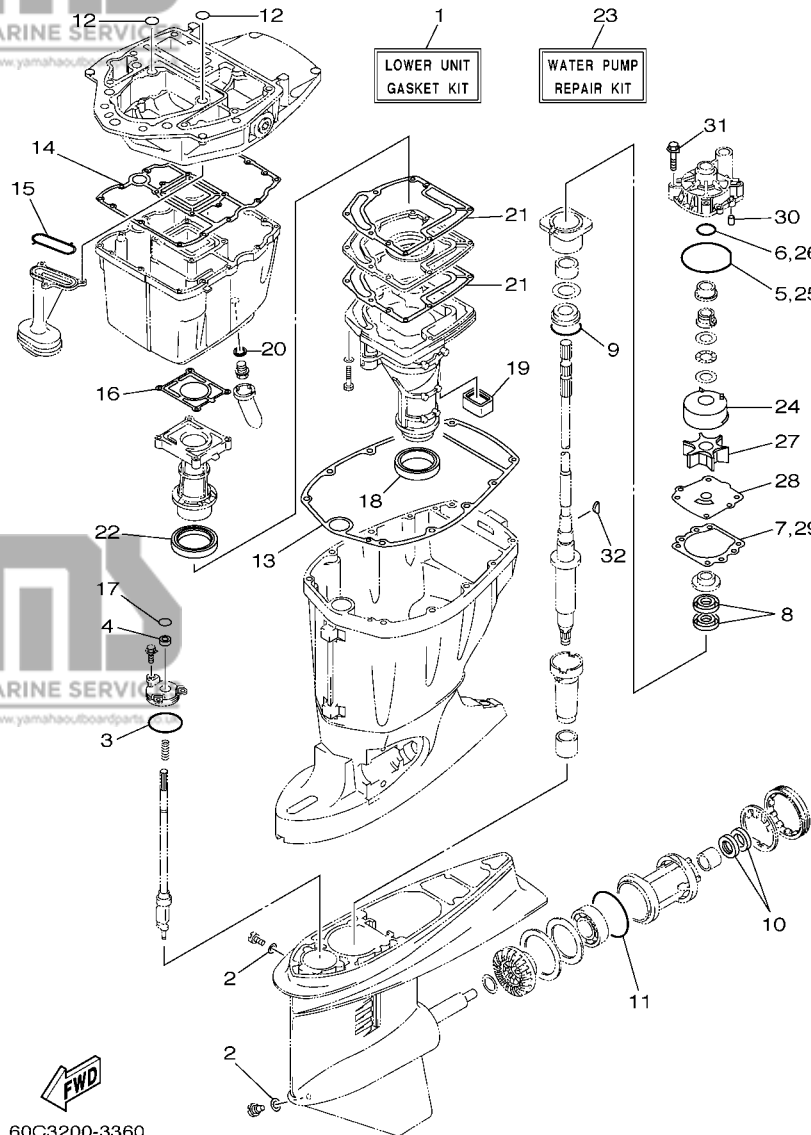

60C3200-3360

FIG. 30 REPAIR KIT 2

KITS DE REPARATION 2

REF. NO.	PART NO. N° PIECES	DESCRIPTION DESCRIPTION	60K2	REMARKS REMARQUES
1	68V-W0001-21	LOWER UNIT GASKET KIT POCHETTE DE JOINTS EMBASE	1	
2	90430-08020	.GASKET .JOINT	2	
3	93210-58144	.O-RING .JOINT TORIQUE	1	
4	93106-09014	.OIL SEAL .JOINT SPY	1	
5	93210-86M38	.O-RING .JOINT TORIQUE	1	
6	93210-37160	.O-RING .JOINT TORIQUE	1	
7	6E5-44315-A0	.GASKET, WATER PUMP .JOINT, POMPE A EAU	1	
8	93101-28M16	.OIL SEAL .JOINT SPY	2	
9	93210-55M14	.O-RING .JOINT TORIQUE	1	
10	93101-30M17	.OIL SEAL .JOINT SPY	2	
11	93210-86M39	.O-RING .JOINT TORIQUE	1	
12	93210-19MJ1	.O-RING .JOINT TORIQUE	2	
13	67F-45113-00	.GASKET, UPPER CASING .JOINT, TUBE D'ARBRE	1	
14	68V-15312-00	.GASKET, OIL PAN .JOINT DE VENTILATEUR D'HUILE	1	
15	67F-13415-00	.SEAL, OIL STRAINER .JOINT, FILTRE A HUILE	1	
16	67F-41133-A1	.GASKET, EXHAUST MANIFOLD 1 .JOINT, PIPE D'ECHAPPEMENT	1	
17	93210-09165	.O-RING .JOINT TORIQUE	1	
18	68V-45123-00	.GASKET, MUFFLER .JOINT, POT DE DETENTE	1	
19	67F-45127-00	.SEAL .JOINT	1	
20	90430-14M09	.GASKET .JOINT	1	
21	67F-41134-A0	.GASKET, EXHAUST MANIFOLD .JOINT, PIPE D'ECHAPPEMENT	2	
22	67F-41138-00	.SEAL, EXT. 1 .JOINT DE GROUPE 1	1	
23	60C-W0078-00	WATER PUMP REPAIR KIT KIT DE REPARATION DE LA POMPE	1	
24	6R3-44322-42	.INSERT, CARTRIDGE .CUVETTE	1	
25	93210-86M38	.O-RING .JOINT TORIQUE	1	
26	93210-37160	.O-RING .JOINT TORIQUE	1	
27	6E5-44352-01	.IMPELLER .TURBINE	1	

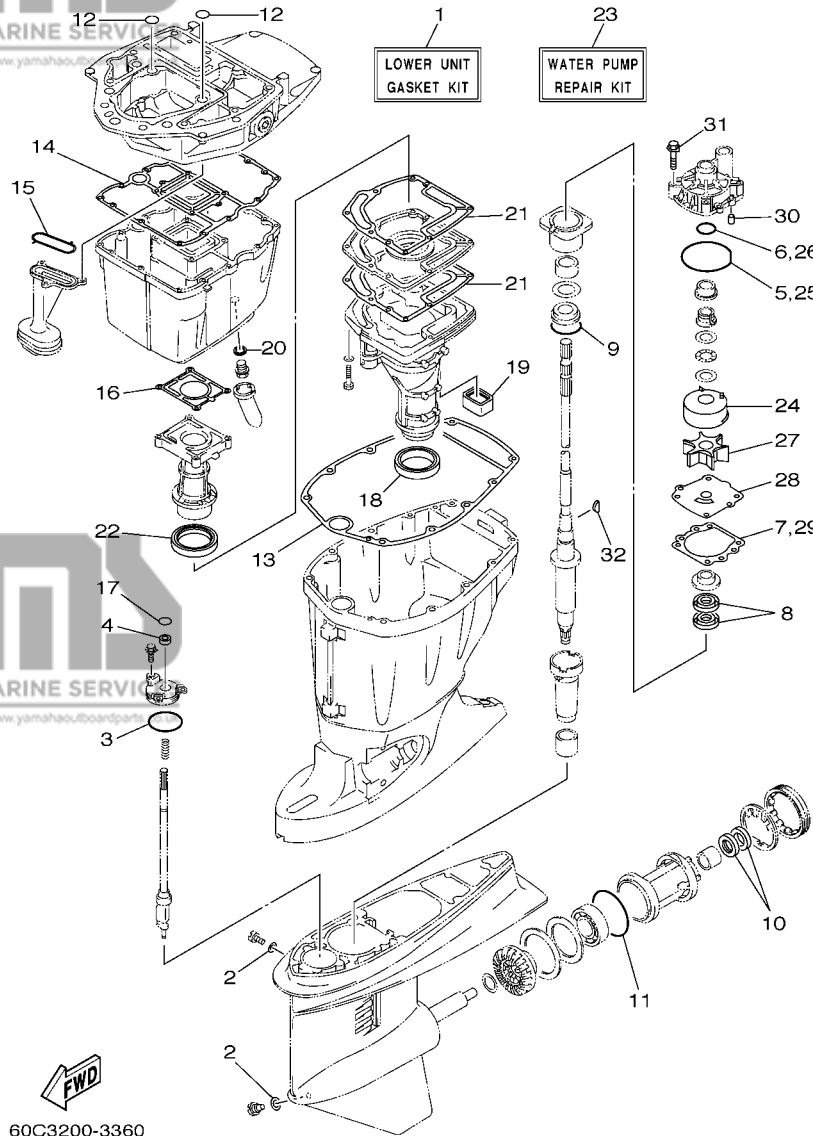

60C3200-3360

**FIG. 30 REPAIR KIT 2**

**KITS DE REPARATION 2**

REF. NO.	PART NO. N° PIECES	DESCRIPTION DESCRIPTION	60K2	REMARKS REMARQUES
28	60C-44323-40	.OUTER PLATE, CARTRIDGE .PLAQUE EXTERIEURE	1	
29	6E5-44315-A0	.GASKET, WATER PUMP .JOINT, POMPE A EAU	1	
30	93606-12019	.PIN, DOWEL .GOUILLE	2	
31	90119-08M14	.BOLT, WITH WASHER .BOULON, AVEC RONDELLE	4	
32	90280-04M05	.KEY, WOODRUFF .CLAVETTE, DEMI-LUNE	1	









FLOOD MARINE SERVICES  
downloaded from www.yamahaoutboardparts.co.uk

PART NO. N° PIECES	REF. NO.
93306-208U0	25 - 59
93315-425U7	25 - 47
93315-430U8	25 - 62
93315-628U9	25 - 3
93317-330U2	25 - 36
93332-000U7	25 - 4
93341-930V2	25 - 38
93410-22M11	21 - 14
93410-37M04	22 - 7
93420-36M01	23 - 24
93501-04M02	19 - 22
93503-16003	25 - 54
93507-32009	25 - 52
93511-32017	25 - 53
93604-12M07	24 - 28
93605-10108	5 - 14
93606-12019	2 - 3
	24 - 7
	25 - 32
	30 - 30
93606-19M23	23 - 15
93608-12M05	26 - 5
93608-16M16	23 - 5
	23 - 22
93700-06M03	20 - 10
	20 - 22
94702-00391	4 - 36
95333-08600	17 - 32
95380-05600	19 - 46
95380-06600	1 - 4
	18 - 42
95380-08600	11 - 11
95380-12600	20 - 37
95380-14600	22 - 14
95895-06025	7 - 25
97013-06020	14 - 2
97013-08045	17 - 30
97027-06025	24 - 10
97075-06025	19 - 20
	24 - 5
97075-06030	23 - 13
97075-06070	23 - 9
97095-06010	8 - 12
	14 - 10
	20 - 25
	23 - 30
97095-06012	1 - 6
	7 - 22



NUMERICAL INDEX  
INDEX NUMERIQUE

PART NO. N° PIECES	REF. NO.	PART NO. N° PIECES	REF. NO.
97095-06012	8 - 4		
	15 - 11		
	15 - 17		
	16 - 9		
97095-06014	13 - 22		
	14 - 23		
	15 - 14		
97095-06016	8 - 23		
	11 - 12		
	13 - 28		
	15 - 7		
	15 - 20		
	16 - 2		
	18 - 13		
97095-06020	2 - 9		
	7 - 10		
97095-06025	4 - 31		
	13 - 15		
	13 - 25		
	19 - 42		
97095-06030	4 - 24		
	7 - 6		
	12 - 10		
	20 - 4		
97095-06035	19 - 33		
97095-06045	24 - 26		
97095-08020	20 - 12		
97095-08025	25 - 41		
97575-08540	2 - 39		
	4 - 13		
	23 - 4		
97575-10530	21 - 8		
97595-06550	19 - 6		
97607-04110	12 - 6		
97780-60620	14 - 9		
97780-60625	14 - 6		
	14 - 30		
97880-05014	16 - 18		
97880-06016	23 - 26		
97885-06012	20 - 8		
97985-04116	19 - 49		
97985-06210	12 - 17		
98507-04008	4 - 20		
98780-04016	2 - 17		
99001-08600	25 - 18		
99530-08012	12 - 9		



FLOOD MARINE SERVICES  
downloaded from www.yamahaoutboardparts.co.uk

PART NO. N° PIECES	REF. NO.
-----------------------	-------------

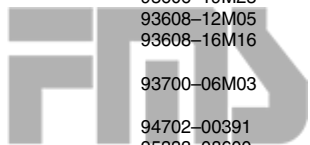

FLOOD MARINE SERVICES  
downloaded from www.yamahaoutboardparts.co.uk



FLOOD MARINE SERVICES  
downloaded from www.yamahaoutboardparts.co.uk



FLOOD MARINE SERVICES  
downloaded from www.yamahaoutboardparts.co.uk



FLOOD MARINE SERVICES  
downloaded from www.yamahaoutboardparts.co.uk



FLOOD MARINE SERVICES  
downloaded from www.yamahaoutboardparts.co.uk



FLOOD MARINE SERVICES  
downloaded from www.yamahaoutboardparts.co.uk