



# PARTS CATALOGUE CATALOGUE DE PIÈCES DÉTACHÉES

**F30A'04 (69H4)**  
**F40B'04 (67C3)**



1C69H-300F1

( 2C69H-300F1 )

2014/7/18

NEWS NO.	DATE	COMMENT
PE0-OM-070029	July,24,2007	MOD:FIG.23 POWER TRIM & TILT ASSY LIST/ILLUSTRATION REVISION
PE0-OM-080001	Jan.,31,2008	COR:FIG.23 PTT(67C-43800-00-4D) P/No. CORRECTION
PE0-OM-110005	Mar.,3,2011	MOD:FIG.6 INTAKE LIST REVISION
PE0-OM-140007	July,1,2014	MOD:FIG.23 PTT(67C-43800-00-4D) LIST/ILLUSTRATION REVISION

# FOREWORD

This Parts Catalogue is related to the parts for the model(s) on the cover page. When you are ordering replacement parts, please refer to this Parts Catalogue and quote both part numbers and part names correctly.

1. Modifications or additions which have been made after the issue of the Parts Catalogue will be announced in the Parts News. It is advisable that you make the necessary corrections to the Parts Catalogue according to the Parts News.

2. Abbreviations  
The following abbreviations are used in this Parts Catalogue.

“UR” Use specified parts number.  
 “UN” Use as many as needed.  
 “AP” Alternate Parts  
 “LM” Locally Made (Parts need to be ordered locally)  
 “F#” Frame No. (Applicable machine No.)  
 “O/S” Over Size

3. The number of components for assembly
  - Parts, which are to be supplied in an assembly, are listed with a dot (.) in front of the part name as shown below.
  - The numeral appearing to the right of each component part indicates the quantity of parts for each assembly unit.

PART NO.	DESCRIPTION	Q'TY	REMARKS
2F5-83310-60	FRONT FLASHER LIGHT ASSY	2	
115-83311-60	.BULB (6V-18W)	1	

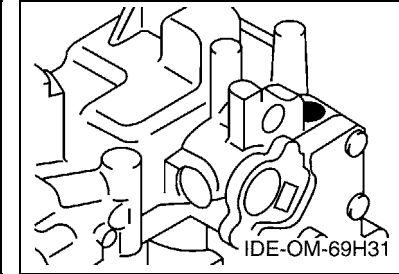
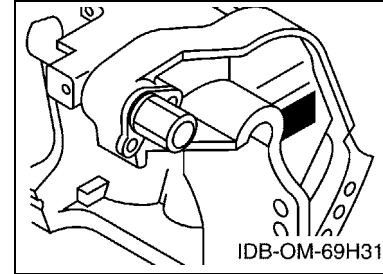
4. Applicable colours of graphics are represented in the “REMARKS” as shown below.

PART NO.	DESCRIPTION	Q'TY	REMARKS
2N4-24110-00-X5	FUEL TANK COMP.	2	MXR
3J1-24240-10	.GRAPHIC, FUEL TANK	1	FOR MXR

5. Note that the illustrations for reference in finding parts numbers are not to be used for assembling. When assembling, please use the applicable service manual.

6. The asterisk (\*) before a reference number indicates modified items after the first edition.
7. Applicable Serial No.

Engine Serial No.



8. Applicable Engine Starting Serial No.

Model	Serial No.	Model	Serial No.
F30A	69H-1001210	F40B	67C-1005782

9. Applicable Colour Code

Abbreviation	Colour Name	Colour Code
DBNM2	DARK BLUISH GRAY METALLIC 2	004D

10. Quantity Column Information

Column No.	Name Of Q'ty Column	Applicable Model
1	MHD	F30AMHD,F40BMHD
2	ED	F40BED
3	ET	F30AET,F40BET

## AVANT-PROPOS

Ce catalogue de pièces détachées concerne les pièces pour le(s) modèle(s) indiqué(s) sur la page de couverture. Lorsque vous commandez des pièces de rechange, veuillez vous référer à ce catalogue de pièces détachées et indiquer clairement les numéros et les noms des pièces détachées.

1. Les modifications ou ajouts ayant été effectués après la parution du catalogue de pièces détachées seront décrits dans les Bulletins d'information concernant les pièces détachées.  
Il est recommandé que vous apportiez les corrections nécessaires au catalogue des pièces détachées en vous référant aux Bulletins d'information.

### 2. Abréviations

Dans ce catalogue, les abréviations suivantes sont utilisées:

- "UR" Utiliser le numéro de pièces spécifié.
- "UN" Utiliser autant que nécessaire.
- "AP" Pièces de substitution
- "LM" Fabrication locale (les pièces doivent être commandées localement.)
- "F#" N° de cadre (applicable au N° de série)
- "O/S" Surdimensionné

### 3. Nombre de pièces d'un assemblage

- Les pièces fournies comme composants d'un assemblage sont précédées d'un point (.) de la manière indiquée ci-dessous.
- Le chiffre apparaissant à la droite de chaque composant indique la quantité de pièces pour chaque unité d'assemblage.

N° PIECES	DESCRIPTION	QTE	REMARQUES
2F5-83310-60	ENS. CLIGNOTANT AVANT	2	
115-83311-60	.AMPOULE (6V-18W)	1	

4. Les couleurs concernant les graphiques sont indiquées dans la colonne "REMARQUES", comme indiqué ci-dessous.

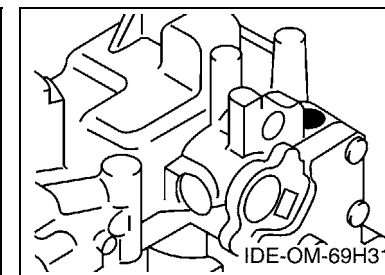
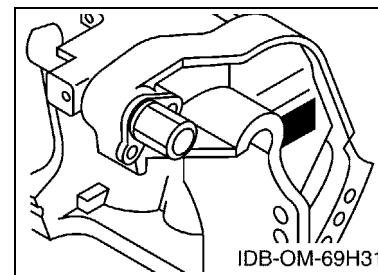
N° PIECES	DESCRIPTION	QTE	REMARQUES
2N4-24110-00-X5	RESERVOIR A ESSENCE.	2	MXR
3J1-24240-10	.GRAPHIQUE	1	POUR MXR

5. Veuillez noter que les illustrations sont indiquées à titre de référence pour trouver les numéros de pièces, non pour être utilisées lors de l'assemblage. Lors de l'assemblage, veuillez utiliser le manuel d'entretien adéquat.

6. L'astérisque (\*) placé devant un numéro de référence indique des éléments qui ont été modifiés après la première édition.

### 7. N° de série applicable

N° de Série du moteur



### 8. N° de série initial du moteur applicable

Modèle	N° de série	Modèle	N° de série
F30A	69H-1001210	F40B	67C-1005782

### 9. Code couleur applicable

Abréviation	Nom de la couleur	Code couleur
DBNM2	DARK BLUISH GRAY METALLIC 2	004D

### 10. Informations relatives à la colonne Quantité

N° de la colonne	Nom de la colonne Qté	Modèle applicable
1	MHD	F30AMHD,F40BMHD
2	ED	F40BED
3	ET	F30AET,F40BET

**SHEET1/2**

TOP COWLING .....	A4
CYLINDER & CRANKCASE 1 .....	A5
CRANKSHAFT & PISTON .....	A6
CYLINDER & CRANKCASE 2 .....	A7
VALVE .....	B2
INTAKE .....	B3
CARBURETOR .....	B5
OIL PUMP .....	C1
FUEL .....	C2
STARTER .....	C4
GENERATOR .....	C6
ELECTRICAL 1 .....	C7
ELECTRICAL 2 .....	D1
ELECTRICAL 3 .....	D3
ELECTRICAL 4 .....	D4
STARTING MOTOR .....	D5
BOTTOM COWLING .....	D6
STEERING .....	E2
CONTROL .....	E5
BRACKET 1 .....	E7
BRACKET 2 .....	F2
BRACKET 3 .....	F4
POWER TRIM & TILT ASSY .....	F6

**INDEX**

NUMERICAL INDEX .....	G1
-----------------------	----

**SHEET2/2**

POWER TRIM & TILT ASSY .....	A4*
UPPER CASING .....	A5*
OIL PAN .....	A6*
LOWER CASING & DRIVE 1 .....	A7*
LOWER CASING & DRIVE 2 .....	B3*
FUEL TANK .....	B5*
STEERING GUIDE .....	B6*
REMOTE CONTROL BOX .....	B7*
REMOTE CONTROL ASSY .....	C1*
METER .....	C4*
REPAIR KIT 1 .....	C5*
REPAIR KIT 2 .....	C6*
REPAIR KIT 3 .....	C7*

**INDEX**

NUMERICAL INDEX .....	G1*
-----------------------	-----

# TABLE DES MATIERES

Feuille1/2

CAPOT SUPERIEUR .....	A4
CYLINDRE & CARTER 1 .....	A5
VILEBREQUIN & PISTON .....	A6
CYLINDRE & CARTER 2 .....	A7
SOUPAPE .....	B2
ADMISSION .....	B3
CARBURATEUR .....	B5
POMPE A HUILE .....	C1
CARBURANT .....	C2
DEMARREUR .....	C4
GENERATRICE .....	C6
PARTIE ELECTRIQUE 1 .....	C7
PARTIE ELECTRIQUE 2 .....	D1
PARTIE ELECTRIQUE 3 .....	D3
PARTIE ELECTRIQUE 4 .....	D4
DEMARREUR ELECTRIQUE .....	D5
CAPOT INFERIEUR .....	D6
DIRECTION .....	E2
COMMANDE .....	E5
SUPPORT 1 .....	E7
SUPPORT 2 .....	F2
SUPPORT 3 .....	F4
PUISSANCE PARER ET INCLINER .....	F6

INDEX

INDEX NUMERIQUE .....	G1
-----------------------	----

Feuille2/2

PUISSANCE PARER ET INCLINER .....	A4*
FOURREAU .....	A5*
VENTILATEUR D'HUILE .....	A6*
BOITIER D'HELICE TRANSMISSION1 .....	A7*
BOITIER D'HELICE TRANSMISSION2 .....	B3*
RESERVOIR A CARBURANT .....	B5*
FIXATION DE DIRECTION .....	B6*
BOITIER DE COMMANDE A DISTANCE .....	B7*
BOITIER DE COMMANDE A DISTANCE .....	C1*
COMPTEUR .....	C4*
KITS DE REPARATION 1 .....	C5*
KITS DE REPARATION 2 .....	C6*
KITS DE REPARATION 3 .....	C7*

INDEX

INDEX NUMERIQUE .....	G1*
-----------------------	-----

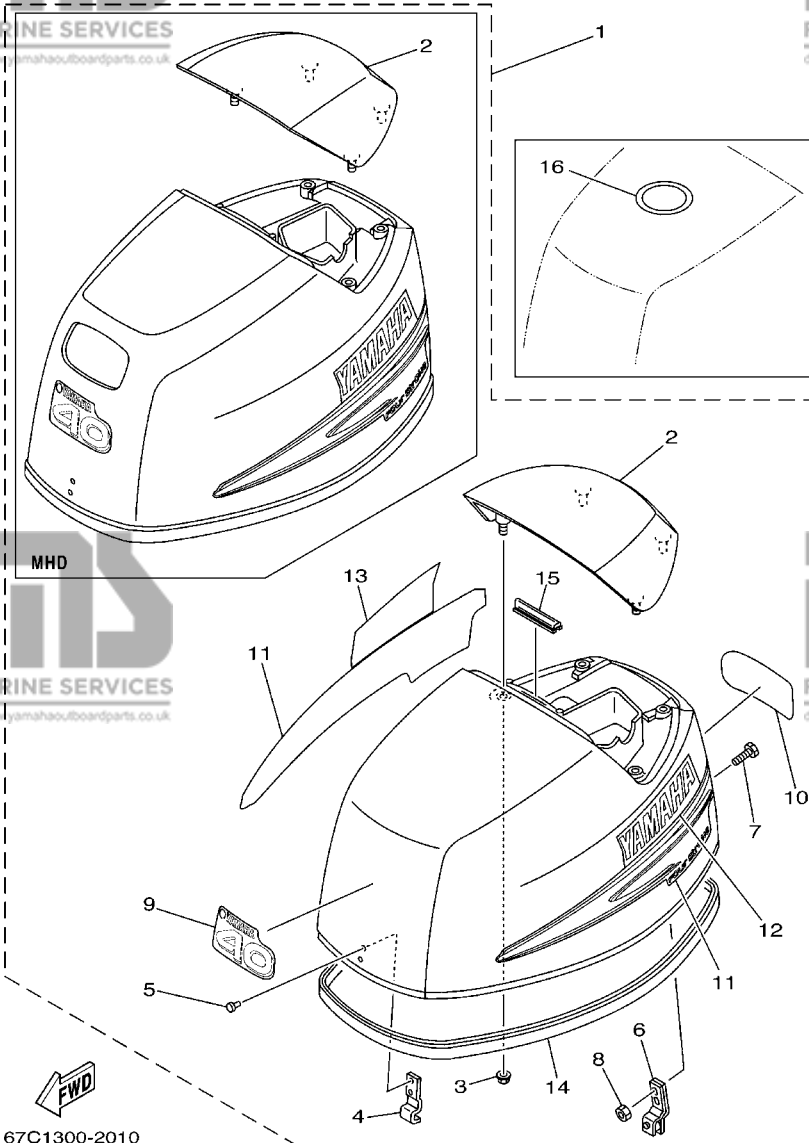
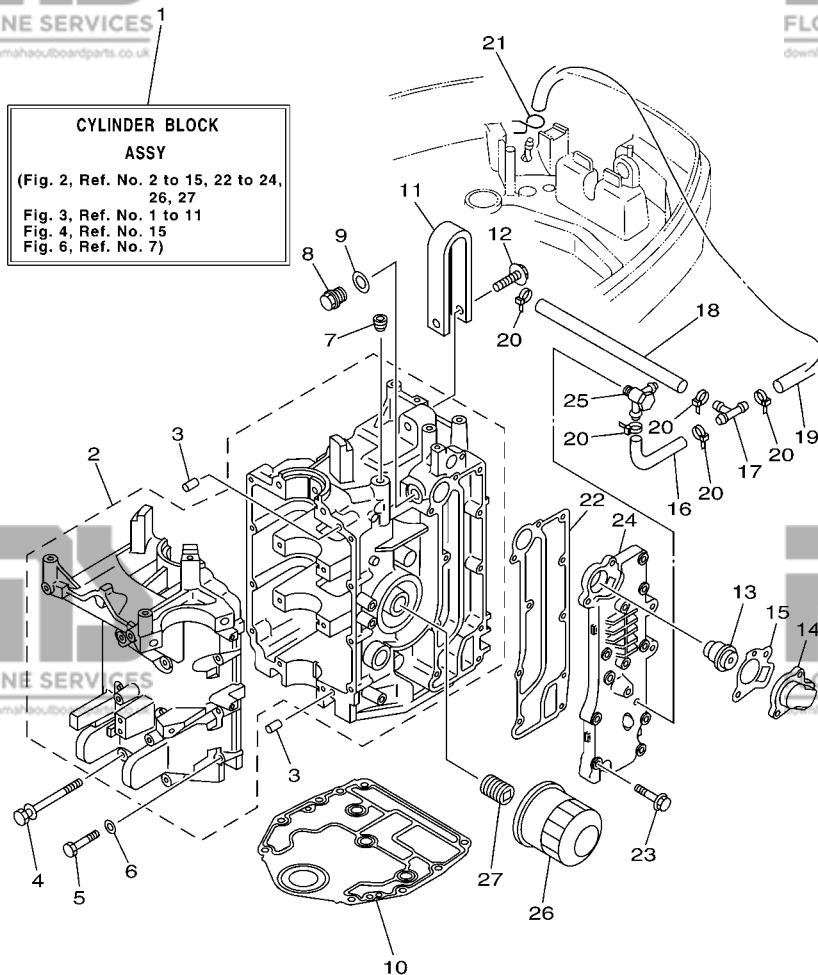


FIG. 1 TOP COWLING

CAPOT SUPERIEUR

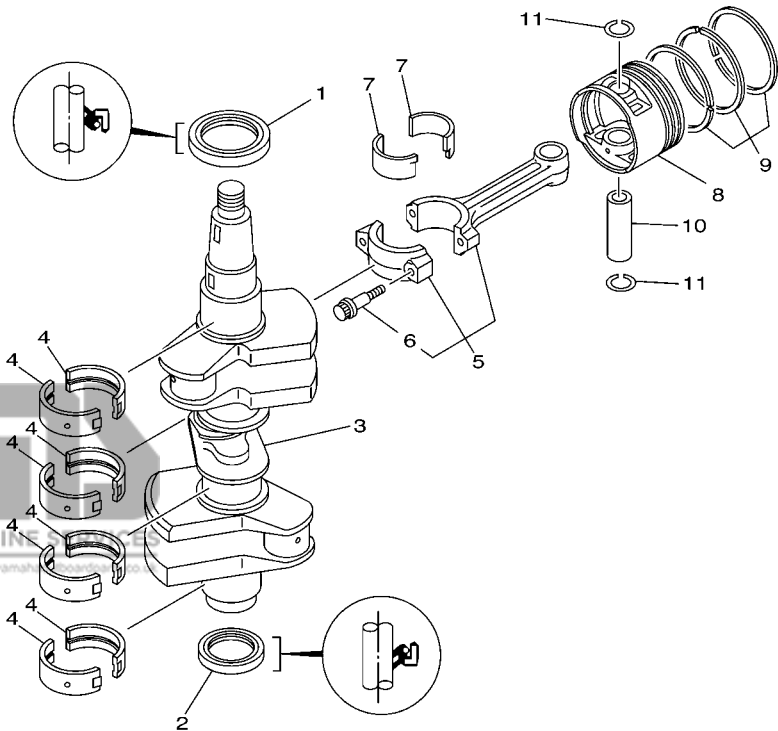
REF. NO.	PART NO. N° PIECES	DESCRIPTION DESCRIPTION	MHD	ED	ET	REMARKS REMARQUES
1	67C-42610-20-4D	TOP COWLING ASSY CAPOT (ENS.)		1	1	F40B F40B
	67C-42610-30-4D	TOP COWLING ASSY CAPOT (ENS.)		1		F40B F40B
	69H-42610-20-4D	TOP COWLING ASSY CAPOT (ENS.)			1	F30A F30A
	69H-42610-30-4D	TOP COWLING ASSY CAPOT (ENS.)		1		F30A F30A
2	67C-42613-00-4D	.MOLDING, AIR DUCT .MANCHON A AIR		1	1	
	67C-42613-10-4D	.MOLDING, AIR DUCT .MANCHON A AIR		1		
3	90179-06M24	.NUT .ECROU		4	4	
4	62Y-42651-00	.HOOK .CROCHET		1	1	
5	90266-06M02	.RIVET .RIVET		2	2	
6	67C-42652-00	.HOOK .CROCHET		1	1	
7	90109-06MA4	.BOLT .BOULON		2	2	
8	95380-06700	.NUT .ECROU		2	2	
9	67C-42677-00	.GRAPHIC, FRONT .ADHESIF, AVANT		1	1	F40B F40B
	69H-42677-10	.GRAPHIC, FRONT .ADHESIF, AVANT		1	1	F30A F30A
10	67C-42678-00	.GRAPHIC, REAR .ADHESIF, ARRIERE		1	1	F40B F40B
	69H-42678-10	.GRAPHIC, REAR .ADHESIF, ARRIERE		1	1	F30A F30A
11	67C-W0070-10	.GRAPHIC SET JEU DIEMBLEMES		1	1	
12	67C-42681-10	.MARK, COWLING .ADHESIF, CAPOT		1	1	
13	67C-42682-10	.MARK, COWLING .ADHESIF, CAPOT		1	1	
14	67C-42615-00	.SEAL .JOINT		1	1	
15	61N-42628-00	.SEAL .JOINT		1	1	
16	67F-13434-02	LABEL, CAUTION ETIQUETTE, ATTENTION		1	1	



67C3110-C020

**FIG. 2 CYLINDER & CRANKCASE 1      CYLINDRE & CARTER 1**

REF. NO.	PART NO. N° PIECES	DESCRIPTION DESCRIPTION	MHD	ED	ET	REMARKS REMARQUES
1	67C-W009B-02-1S	CYLINDER BLOCK ASSY CYLINDRE GROUPE (ENS.)	1	1	1	
2	67C-15100-01-94	CRANKCASE ASSY CARTER DE MOTEUR COMPLET	1	1	1	
3	99530-08012	PIN, DOWEL GOUJON, D'ASSEMBLAGE	2	2	2	
4	90119-08M01	BOLT, WITH WASHER BOULON, AVEC RONDELLE	8	8	8	
5	97013-06035	BOLT BOULON	8	8	8	
6	92903-06600	WASHER, PLATE RONDELLE, PLATE	8	8	8	
7	90344-51M01	PLUG, TAPER SCREW PLOT, FILETE CONIQUE	1	1	1	
8	90340-14M06	PLUG, STRAIGHT SCREW PLOT, FILETE DROIT	1	1	1	
9	90430-14115	GASKET JOINT	1	1	1	
10	67C-11351-01	GASKET, CYLINDER JOINT, D'EMBASE	1	1	1	
11	65W-11119-00	HANGER, ENGINE ANNEAU, LEVAGE	1	1	1	
12	90105-08M87	BOLT, FLANGE BOULON	1	1	1	
13	6G8-12411-02	THERMOSTAT THERMOSTAT	1	1	1	
14	6H3-12413-00-1S	COVER, THERMOSTAT COUVERCLE, THERMOSTAT	1	1	1	
15	62Y-12414-00	GASKET, COVER JOINT, COUVERCLE	1	1	1	
16	90445-09068	HOSE (L110) DURITE (L110)	1	1	1	
17	688-24378-00	PIPE, JOINT 4 DURITE RACCORDEMENT 4	1	1	1	
18	90445-09095	HOSE (L215) DURITE (L215)	1	1	1	
19	90445-09105	HOSE (L300) DURITE (L300)	1	1	1	
20	90465-11M10	CLAMP BRIDE	5	5	5	
21	90467-08004	CLIP JONC	1	1	1	
22	67C-41114-10	GASKET, EXHAUST OUTER COVER JOINT, COUVERCLE D'ECHAPPEMENT	1	1	1	
23	90119-06MA5	BOLT, WITH WASHER BOULON, AVEC RONDELLE	10	10	10	
24	67C-41113-01-1S	OUTER COVER, EXHAUST COUVERCLE, ECHAPPEMENT	1	1	1	
25	62Y-11372-01	NIPPLE, HOSE RACCORD, TUYAU	1	1	1	FLUSHING KIT FLUSHING KIT
26	5GH-13440-00	ELEMENT ASSY, OIL CLEANER ELEMENT, FILTRE A HUILE	1	1	1	
27	90401-20M00	BOLT, UNION BOULON, RACCORD	1	1	1	



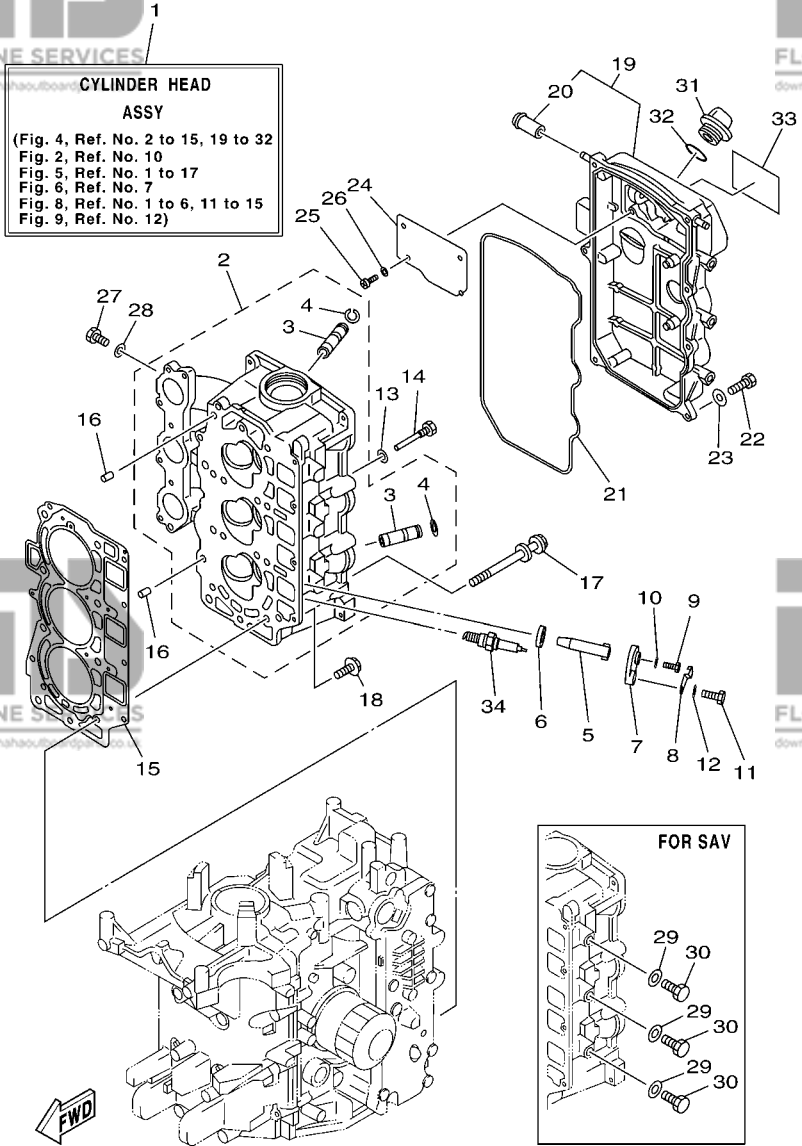
**FWD**  
67C0010-0031

**FIG. 3 CRANKSHAFT & PISTON**

**VILEBREQUIN & PISTON**

REF. NO.	PART NO. N° PIECES	DESCRIPTION DESCRIPTION	MHD	ED	ET	REMARKS REMARQUES
1	93102-43M42	OIL SEAL JOINT SPY	1	1	1	
2	93102-35M47	OIL SEAL JOINT SPY	1	1	1	
3	67C-11411-00	CRANKSHAFT VILEBREQUIN COMPLET	1	1	1	
4	62Y-11416-00	PLANE BEARING, CRANKSHAFT 1 COUSSINET DE VILEBREQUIN 1	8	8	8	UR BROWN UR BROWN
	62Y-11416-10	PLANE BEARING, CRANKSHAFT 1 COUSSINET DE VILEBREQUIN 1	8	8	8	UR BLACK UR BLACK
	62Y-11416-20	PLANE BEARING, CRANKSHAFT 1 COUSSINET DE VILEBREQUIN 1	8	8	8	UR BLUE UR BLUE
5	62Y-11650-10	CONNECTING ROD ASSY BIELLE COMPLETE	3	3	3	
6	62Y-11654-00	.BOLT, CONNECTING ROD .BOULON, BIELLE	2	2	2	
7	62Y-11656-00	PLANE BEARING, CONNECTING ROD ROULEMENT DE BIELLE	6	6	6	UR BROWN UR BROWN
	62Y-11656-10	PLANE BEARING, CONNECTING ROD ROULEMENT DE BIELLE	6	6	6	UR BLACK UR BLACK
	62Y-11656-20	PLANE BEARING, CONNECTING ROD ROULEMENT DE BIELLE	6	6	6	UR BLUE UR BLUE
8	65W-11631-00-96	PISTON (STD) PISTON (STD)	3	3	3	
	65W-11635-00	PISTON (0.25MM O/S) PISTON (0.25MM O/S)	3	3	3	AP AP
	65W-11636-00	PISTON (0.50MM O/S) PISTON (0.50MM O/S)	3	3	3	AP AP
9	67C-11603-00	PISTON RING SET (STD) JEU DE SEGMENTS (STD)	3	3	3	
	67C-11604-00	PISTON RING SET (0.25MM O/S) JUE DE SEGMENTS (0.25MM O/S)	3	3	3	AP AP
	67C-11605-00	PISTON RING SET (0.50MM O/S) JEU DE SEGMENTS (0.50MM O/S)	3	3	3	AP AP
10	62Y-11633-00	PIN, PISTON AXE, PISTON	3	3	3	
11	93450-17129	CIRCLIP CIRCLIP	6	6	6	



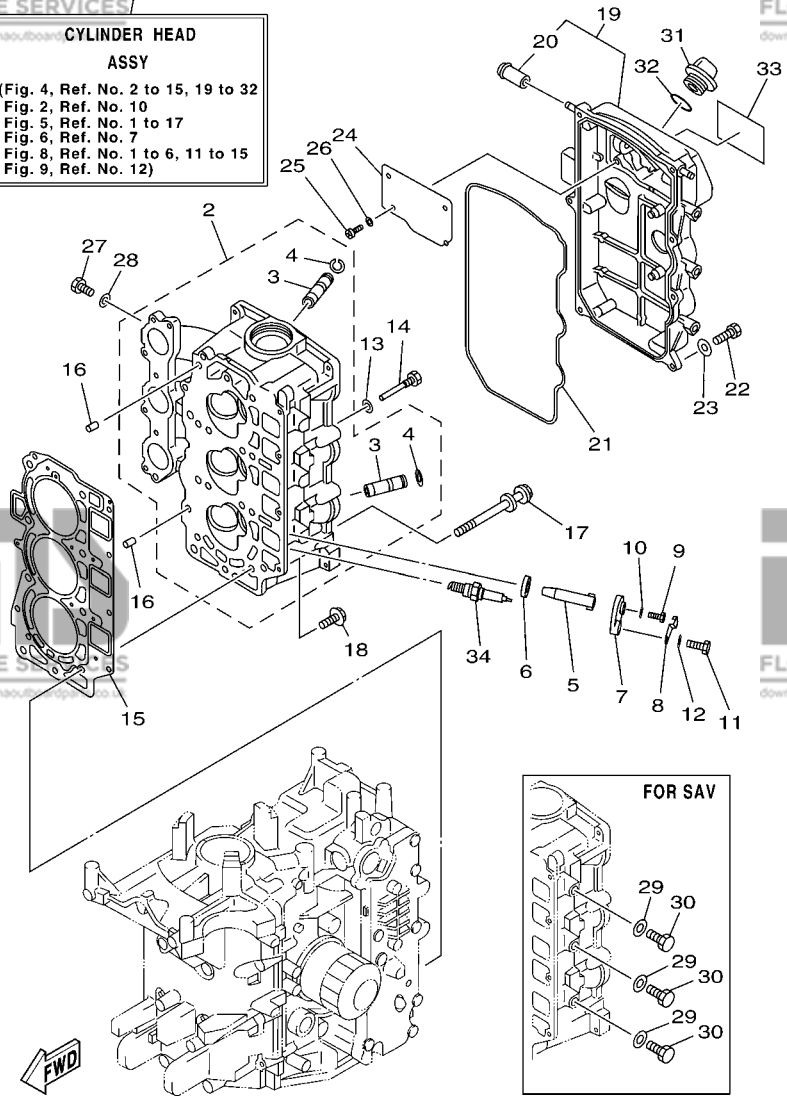


67C3300-C040

FIG. 4 CYLINDER & CRANKCASE 2 CYLINDRE & CARTER 2

REF. NO.	PART NO. N° PIECES	DESCRIPTION DESCRIPTION	MFD	ED	ET	REMARKS REMARQUES
1	67C-W009A-01-1S	CYLINDER HEAD ASSY CULASSE (ENS.)	1	1	1	FOR STD FOR STD
	67C-W009A-11-1S	CYLINDER HEAD ASSY CULASSE (ENS.)	1	1	1	FOR SAV FOR SAV
2	67C-11111-03-1S	HEAD, CYLINDER 1 CULASSE	1	1	1	FOR STD FOR STD
	67C-11111-12-1S	HEAD, CYLINDER 1 CULASSE	1	1	1	FOR SAV FOR SAV
3	62Y-11133-10	.GUIDE, VALVE 1 .GUIDE, SOUPAPE 1	6	6	6	
4	93450-09M01	.CIRCLIP .CIRCLIP	6	6	6	
5	62Y-11325-00	ANODE ANODE	3	3	3	
6	66M-11328-00	GROMMET, ANODE PASSE-FIL	3	3	3	
7	66M-11327-00-94	COVER, ANODE COUVERCLE	3	3	3	
8	66M-12535-00	PLATE PLAQUE	3	3	3	
9	97095-05012	BOLT BOULON	3	3	3	
10	92995-05600	WASHER RONDELLE	3	3	3	
11	97095-06020	BOLT BOULON	3	3	3	
12	92995-06600	WASHER RONDELLE	3	3	3	
13	90430-06014	GASKET JOINT	1	1	1	
14	90109-06M65	BOLT BOULON	1	1	1	
15	67C-11181-01	GASKET, CYLINDER HEAD 1 JOINT, DE CULASSE 1	1	1	1	
16	99530-08012	PIN, DOWEL GOUJON, D'ASSEMBLAGE	2	2	2	
17	90119-09M00	BOLT, WITH WASHER BOULON, AVEC RONDELLE	8	8	8	
18	90119-06MA3	BOLT, WITH WASHER BOULON, AVEC RONDELLE	4	4	4	
19	67C-11191-00-1S	COVER, CYLINDER HEAD 1 COUVERCLE, CULASSE 1	1	1	1	
20	62Y-14485-00	.PIPE, JOINT .DURITE	1	1	1	
21	67C-11356-00	SEAL, CYLINDER 2 JOINT, SPY CYLINDRE	1	1	1	
22	97095-06020	BOLT BOULON	7	7	7	
23	92995-06600	WASHER RONDELLE	7	7	7	
24	67C-11168-00	COVER, BREATHER COUVERCLE, RENIFLARD	1	1	1	
25	98507-04010	SCREW, PAN HEAD VIS, TETE TRONCONIQUE	4	4	4	

**CYLINDER HEAD  
ASSY**  
(Fig. 4, Ref. No. 2 to 15, 19 to 32  
Fig. 2, Ref. No. 10  
Fig. 5, Ref. No. 1 to 17  
Fig. 6, Ref. No. 7  
Fig. 8, Ref. No. 1 to 6, 11 to 15  
Fig. 9, Ref. No. 12)



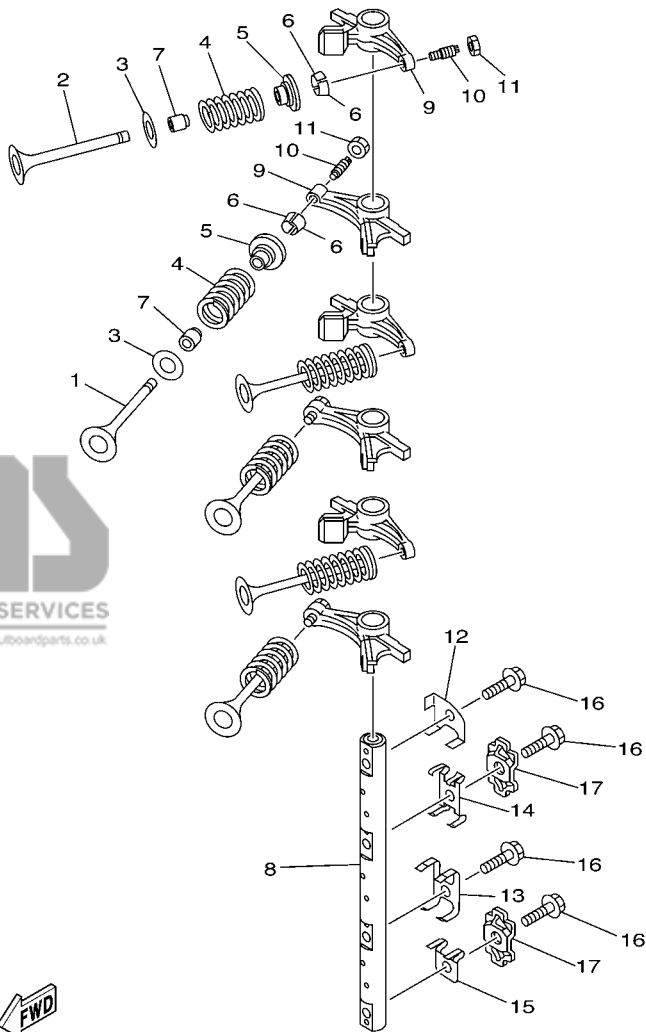
67C3300-C040

**FIG. 4 CYLINDER & CRANKCASE 2**

**CYLINDRE & CARTER 2**

REF. NO.	PART NO. N° PIECES	DESCRIPTION DESCRIPTION	MFD	ED	ET	REMARKS REMARQUES
26	92907-04600	WASHER RONDELLE	4	4	4	
27	97095-06010	BOLT BOULON	3	3	3	
28	90430-06014	GASKET JOINT	3	3	3	
29	90430-08143	GASKET JOINT	3	3	3	FOR SAV
30	97095-08014	BOLT BOULON	3	3	3	FOR SAV
31	6G8-15363-00	PLUG, OIL PLOT, HUILE	1	1	1	FOR SAV
32	93210-24M79	O-RING JOINT TORIQUE	1	1	1	
33	62Y-12138-60	MARK, CAUTION MAKER	1	1	1	
34	94701-00375	PLUG, SPARK (NGK DPR6EA-9) BOUGIE D'ALLUMAGE(NGK DPR6EA-9)	3	3	3	

**B1**



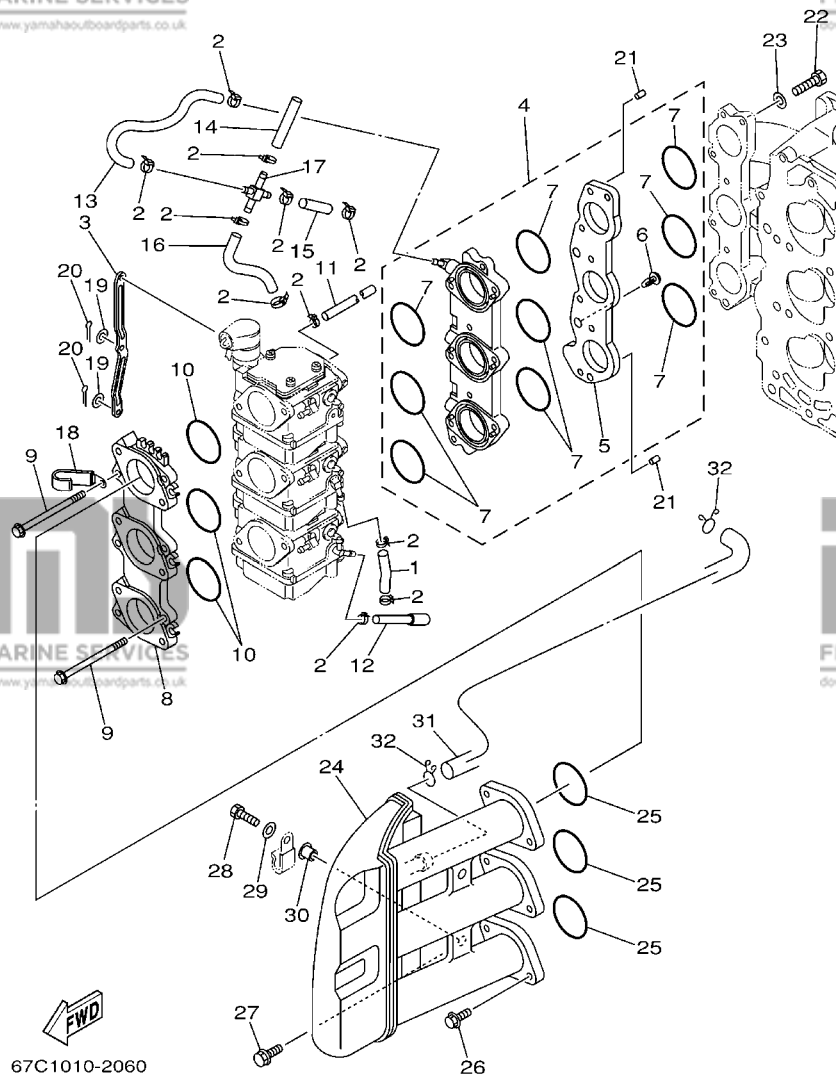
67C1010-2051

**FIG. 5 VALVE**

**SOUPAPE**

REF. NO.	PART NO. N° PIECES	DESCRIPTION DESCRIPTION	MHD	ED	ET	REMARKS REMARQUES
1	67C-12111-00	VALVE, INTAKE SOUPAPE, ADMISSION	3	3	3	
2	62Y-12121-00	VALVE, EXHAUST SOUPAPE, ECHAPPEMENT	3	3	3	
3	62Y-12116-00	SEAT, VALVE SPRING SIEGE, RESSORT DE SOUPAPE	6	6	6	
4	51Y-12114-00	SPRING, VALVE OUTER RESSORT DE SOUPAPE, EXTERNE	6	6	6	
5	30X-12117-00	RETAINER, VALVE SPRING BUTEE DE RESSORT DE SOUPAPE	6	6	6	
6	30X-12118-00	CUTTER, VALVE FRAISE, SOUPAPE	12	12	12	
7	51Y-12119-00	SEAL, VALVE STEM JOINT, QUEUE DE SOUPAPE	6	6	6	
8	67C-12146-00	SHAFT, ROCKER AXE, CULBUTEUR	1	1	1	
9	65W-12151-00	ARM, VALVE ROCKER CULBUTEUR	6	6	6	
10	62Y-12159-00	SCREW, VALVE ADJUSTING VIS, REGLAGE DE SOUPAPE	6	6	6	
11	62Y-12158-00	NUT, LOCK CONTRE-ECROU	6	6	6	
12	62Y-12238-00	PLATE, BOLT STOPPER PLAQUE, BUTEE DE BOULON		1	1	
	64J-12238-00	PLATE, BOLT STOPPER PLAQUE, BUTEE DE BOULON	1			
13	62Y-12279-00	PLATE PLAQUE		1	1	
	64J-12279-00	PLATE PLAQUE	1			
14	62Y-12216-00	SPRING RESSORT	1	1	1	
15	67C-12113-00	SPRING, VALVE INNER RESSORT DE SOUPAPE, INTERNE	1	1	1	
16	90109-08M63	BOLT BOULON	4	4	4	
17	62Y-12231-00	GUIDE, STOPPER 1 GUIDE, BUTEE 1	2	2	2	

**B2**



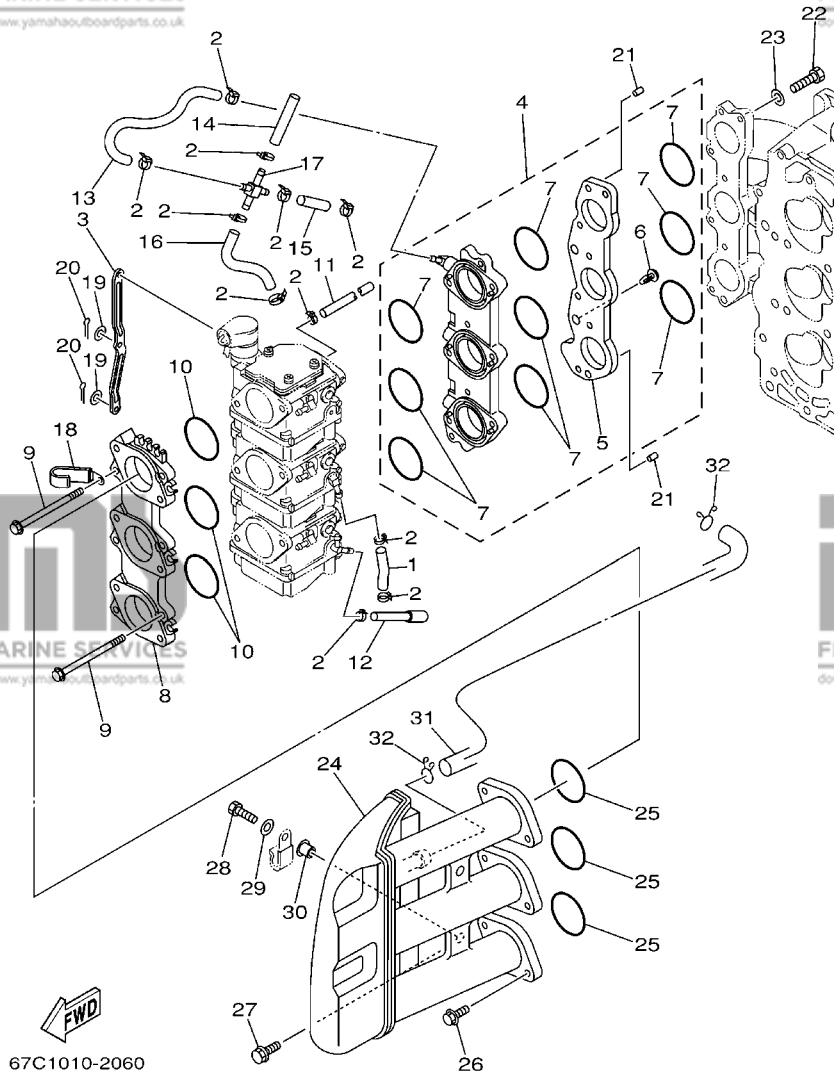
67C1010-2060

**FIG. 6 INTAKE**

**ADMISSION**

REF. NO.	PART NO. N° PIECES	DESCRIPTION DESCRIPTION	MHD	ED	ET	REMARKS REMARQUES
1	90445-09M34	HOSE DURITE	1	1	1	
2	90465-11M10	CLAMP BRIDE	11	11	11	
3	67C-14585-00	LINK, ACCEL. BIELLETTE, ACCELERATION	1	1	1	
4	67C-13589-00	CARBURETOR JOINT COMP. RACCORD, CARBURATEUR	1	1	1	
5	67C-14271-00	.INSULATOR .ISOLATEUR	1	1	1	
6	90338-04M17	.PLUG .PLOT	2	2	2	
7	67C-14561-00	.O-RING .JOINT TORIQUE	9	9	9	
8	67C-14243-01-94	PLATE PLAQUE	1	1	1	
9	97595-06590	BOLT, WITH WASHER VIS HEXAGONAL AVEC RONDELLE	6	6	6	
10	67C-14562-00	O-RING JOINT TORIQUE	3	3	3	
11	67C-13971-00	PIPE, FUEL 1 TUBE 1, CARBURANT	1	1	1	
12	67C-13972-00	PIPE, FUEL 2 TUBE 2, CARBURANT	1	1	1	
13	67C-13973-00	PIPE, FUEL 3 TUBE 3, CARBURANT	1	1	1	
14	67C-14294-00	HOSE DURITE	1	1	1	
15	67C-13975-00	PIPE, FUEL 5 TUBE 5, CARBURANT	1	1	1	
16	67C-13976-00	PIPE, FUEL 6 TUBE 6, CARBURANT	1	1	1	
17	67C-14318-00	PIPE, JOINT 4 DURITE RACCORDEMENT 4	1	1	1	
18	67C-14255-00	CLAMP BRIDE	1	1	1	
19	92990-04600	WASHER, PLATE RONDELLE, PLATE	2	2	2	
20	91490-06012	PIN, COTTER GOUPILLE	2	2	2	
21	93608-16M16	PIN, DOWEL AXE	2	2	2	
22	97095-06025	BOLT BOULON	6	6	6	
23	92995-06600	WASHER RONDELLE	6	6	6	
24	67C-14440-00	SILENCER ASSY, INTAKE SIENCIEUX D'ADMISSION	1	1	1	
25	93210-34MJ6	O-RING JOINT TORIQUE	3	3	3	
26	90119-06M82	BOLT, WITH WASHER BOULON, AVEC RONDELLE	5	5	5	
27	90119-06M86	BOLT, WITH WASHER BOULON, AVEC RONDELLE	1	1	1	

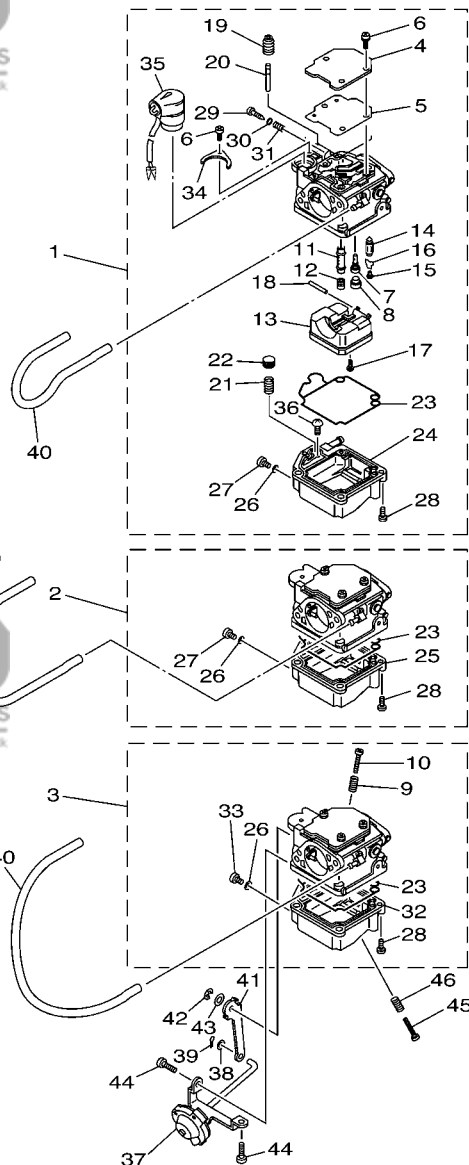
**B3**



**FIG. 6 INTAKE**

**ADMISSION**

REF. NO.	PART NO. N° PIECES	DESCRIPTION DESCRIPTION	MFD	ED	ET	REMARKS REMARQUES
28	97095-06020	BOLT BOULON	2	2	2	
29	92995-06600	WASHER RONDELLE	2	2	2	
30	90387-06M70	COLLAR COLLERETTE	2	2	2	
31	67C-15373-00	PIPE, BREATHER DURITE DE RENIFLARD	1	1	1	
32	90467-15M14	CLIP JONC	2	2	2	



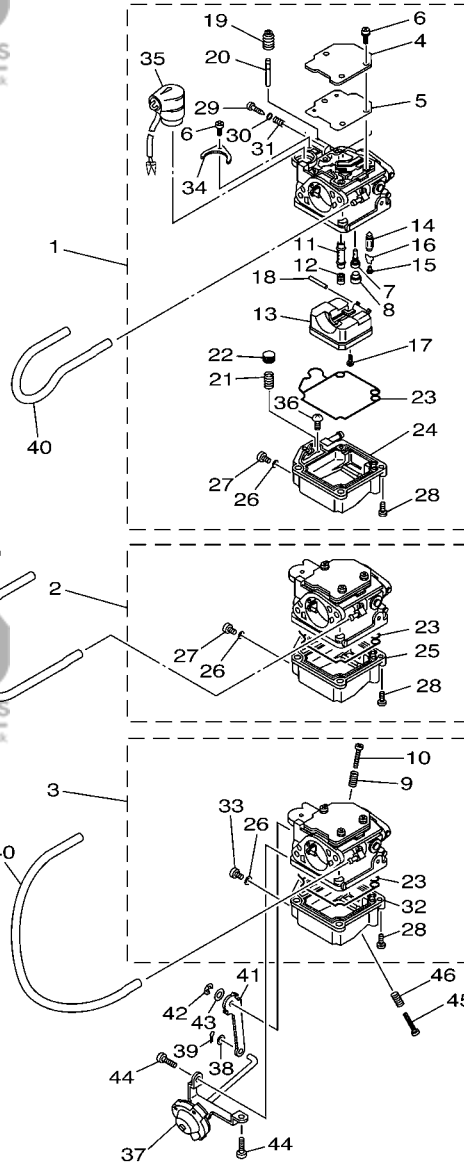
**FWD**  
67C2010-3070

**FIG. 7 CARBURETOR**

**CARBURATEUR**

REF. NO.	PART NO. N° PIECES	DESCRIPTION DESCRIPTION	MFD	ED	ET	REMARKS REMARQUES
1	67C-14901-03	CARBURETOR ASSY 1 CARBURATEUR 1 COMPLET	1	1	1	F40B-FOR STD F40B-FOR STD
	67C-14901-23	CARBURETOR ASSY 1 CARBURATEUR 1 COMPLET		1	1	F40B-FOR SAV F40B-FOR SAV
	69H-14901-02	CARBURETOR ASSY 1 CARBURATEUR 1 COMPLET			1	F30A-FOR STD F30A-FOR STD
	69H-14901-22	CARBURETOR ASSY 1 CARBURATEUR 1 COMPLET	1		1	F30A-FOR SAV F30A-FOR SAV
2	67C-14902-03	CARBURETOR ASSY 2 CARBURATEUR 2 COMPLET	1	1	1	F40B-FOR STD F40B-FOR STD
	67C-14902-23	CARBURETOR ASSY 2 CARBURATEUR 2 COMPLET		1	1	F40B-FOR SAV F40B-FOR SAV
	69H-14902-02	CARBURETOR ASSY 2 CARBURATEUR 2 COMPLET			1	F30A-FOR STD F30A-FOR STD
	69H-14902-22	CARBURETOR ASSY 2 CARBURATEUR 2 COMPLET	1		1	F30A-FOR SAV F30A-FOR SAV
3	67C-14903-03	CARBURETOR ASSY 3 CARBURATEUR 3 COMPLET	1	1	1	F40B-FOR STD F40B-FOR STD
	67C-14903-23	CARBURETOR ASSY 3 CARBURATEUR 3 COMPLET		1	1	F40B-FOR SAV F40B-FOR SAV
	69H-14903-02	CARBURETOR ASSY 3 CARBURATEUR 3 COMPLET			1	F30A-FOR STD F30A-FOR STD
	69H-14903-22	CARBURETOR ASSY 3 CARBURATEUR 3 COMPLET	1		1	F30A-FOR SAV F30A-FOR SAV
4	65W-14572-00	.PLATE .PLAQUE	3	3	3	
5	65W-14126-10	.GASKET .JOINT	3	3	3	
6	97803-04010	.SCREW, PAN HEAD .VIS, CRUCIFORME	13	13	13	
7	67C-14948-02	.JET (#38) .GICLEUR (#38)	3	3	3	F40B-FOR STD F40B-FOR STD
	67C-14948-00	.JET (#40) .GICLEUR (#40)	3	3	3	
8	679-14966-00	.RUBBER CAP .CAOUTCHOUC CASQUILLO	3	3	3	
9	90501-10326	.SPRING, COMPRESSION .RESSORT DE COMPRESSION	1	1	1	#3 #3
10	63V-14523-00	.SCREW, STOP .VIS, BUTEE	1	1	1	#3 #3
11	67C-14948-01	.JET (#35) .GICLEUR (#35)	3	3	3	F40B-FOR STD F40B-FOR STD
	67C-14947-00	.JET, NEEDLE .GICLEUR DE STARTER		3	3	F40B-FOR SAV F40B-FOR SAV
	69H-14947-00	.JET, NEEDLE .GICLEUR DE STARTER	3		3	F30A F30A
12	67C-14943-25	.JET, MAIN (#95) .GICLEUR, PRINCIPAL (#95)	3	3	3	F40B F40B
	69H-14943-22	.JET, MAIN (#88) .GICLEUR, PRINCIPAL (#88)	3		3	F30A F30A
13	63V-14985-00	.FLOAT .FLOTTEUR	3	3	3	
14	6G1-14546-01	.VALVE, NEEDLE .POINTEAU	3	3	3	

**B5**



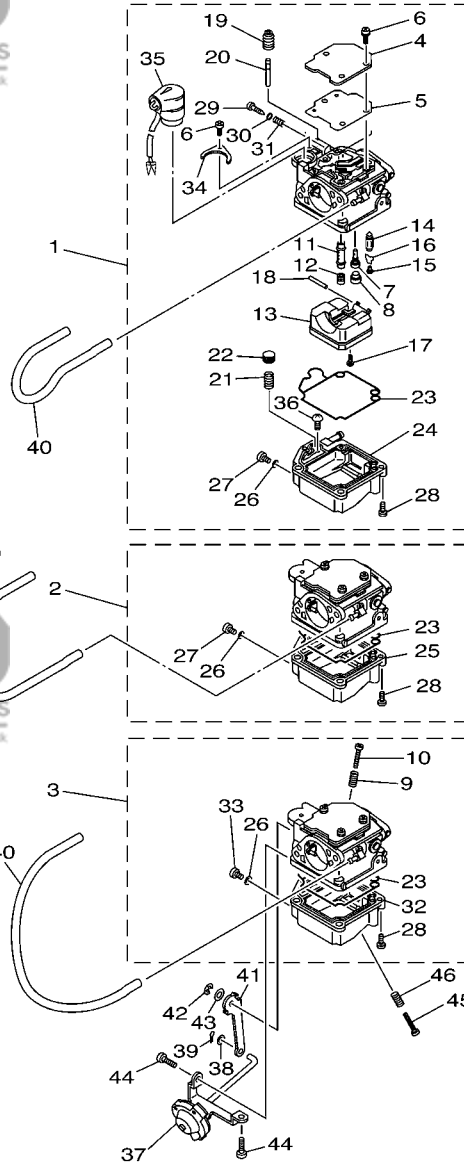
67C2010-3070

**FIG. 7 CARBURETOR**

**CARBURATEUR**

REF. NO.	PART NO. N° PIECES	DESCRIPTION DESCRIPTION	MFD	ED	ET	REMARKS REMARQUES
15	676-14186-00	.PIN, FLOAT .AXE, FLOTTEUR	3	3	3	
16	663-14159-00	.CLIP .JONC	3	3	3	
17	98580-04008	.SCREW, PAN HEAD .VIS	3	3	3	
18	6H4-14548-00	.PIN, FLOAT ARM .AXE, BRAS DE FLOTTEUR	3	3	3	
19	65W-14373-00	.COVER, PLUNGER CAP .COUVERCLE DE PLONGEUR	3	3	3	
20	67C-14379-10	.ROD, STARTER .TRINGLE, STARTER	3	3	3	F40B-FOR STD F40B-FOR STD
	67C-14379-00	.ROD, STARTER .TRINGLE, STARTER	3	3	3	
21	65W-14335-00	.SPRING, PLUNGER .RESSORT, PLONGEUR	3	3	3	
22	67C-14371-00	.PLUNGER, STARTER .PLONGEUR, STARTER	3	3	3	
23	65W-14384-00	.GASKET, FLOAT CHAMBER .JOINT, CUVE DE FLOTTEUR	3	3	3	
24	67C-14980-00	.BODY, FLOAT CHAMBER .CORPS, CUVE DE FLOTTEUR	1	1	1	F40B-#1 F40B-#1
	69H-14980-00	.BODY, FLOAT CHAMBER .CORPS, CUVE DE FLOTTEUR	1	1	1	F30A-#1 F30A-#1
25	67C-14981-00	.BODY, FLOAT CHAMBER .CORPS, CUVE DE FLOTTEUR	1	1	1	F40B-#2 F40B-#2
	69H-14981-00	.BODY, FLOAT CHAMBER .CORPS, CUVE DE FLOTTEUR	1	1	1	F30A-#2 F30A-#2
26	65W-14398-00	.GASKET .JOINT	3	3	3	
27	65W-14992-00	.SCREW, DRAIN .BOUCHON, PURGE	2	2	2	#1,2 #1,2
28	97980-04114	.SCREW, WITH WASHER .VIS, AVEC RONDELLE	12	12	12	
29	67C-14923-00	.SCREW, PILOT .VIS, RALENTI	3	3	3	
	67C-14923-20	.SCREW, PILOT .VIS, RALENTI	3	3	3	F30A-FOR SAV F30A-FOR SAV
30	67C-14397-00	.O-RING .JOINT TORIQUE	3	3	3	
31	67C-14555-00	.SPRING .RESSORT	3	3	3	
32	67C-14982-00	.BODY, FLOAT CHAMBER .CORPS, CUVE DE FLOTTEUR	1	1	1	F40B-#3 F40B-#3
	69H-14982-00	.BODY, FLOAT CHAMBER .CORPS, CUVE DE FLOTTEUR	1	1	1	F30A-#3 F30A-#3
33	67C-14992-00	.SCREW, DRAIN .BOUCHON, PURGE	1	1	1	#3 #3
34	65W-14346-00	.PLATE .PLAQUE	1	1	1	
35	67C-14380-00	.PRIME STARTER ASSY .DEMARREUR D'AMARCAGE ENS.	1	1	1	
36	67C-14567-00	.SCREW .VIS	3	3	3	

**B6**



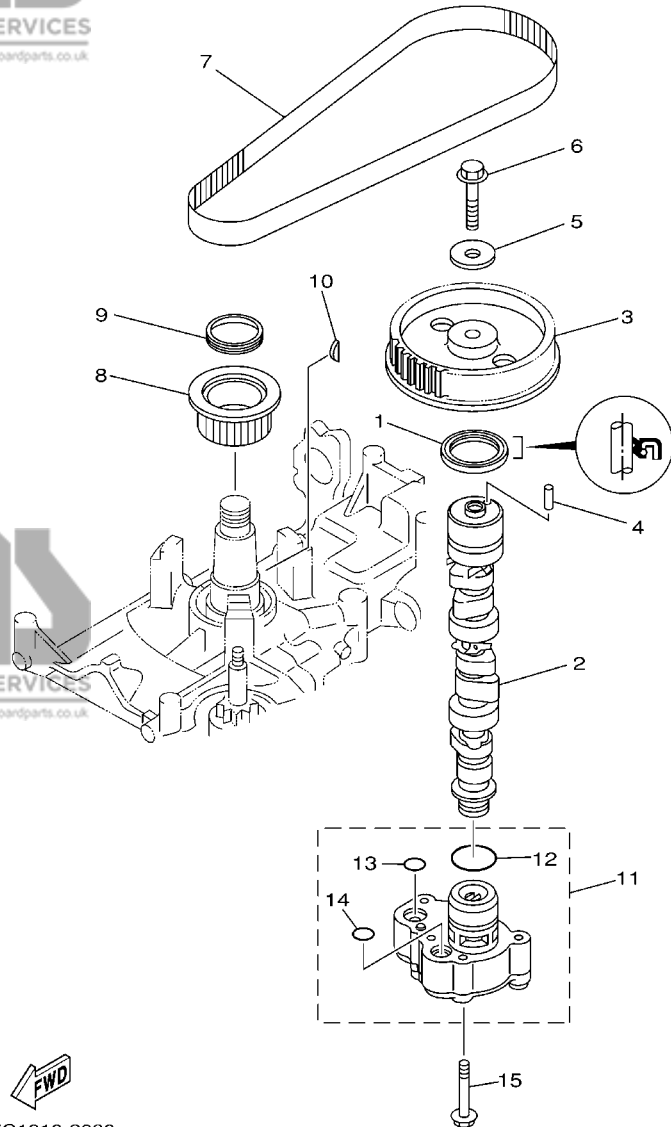
67C2010-3070

**FIG. 7 CARBURETOR**

**CARBURATEUR**

REF. NO.	PART NO. N° PIECES	DESCRIPTION DESCRIPTION	MFD	ED	ET	REMARKS REMARQUES
37	67C-14369-00	DIAPHRAGM ASSY 2 DIAPHRAGME 2	1	1	1	
38	92990-04600	WASHER, PLATE RONDELLE, PLATE	1	1	1	
39	91490-06012	PIN, COTTER GOUPILLE	1	1	1	
40	67C-13974-00	PIPE, FUEL 4 TUBE 4, CARBURANT	3	3	3	
41	67C-14974-00	LEVER, CONNECT LEVIER, CONNECTEUR	1	1	1	
42	67C-14356-00	CLIP JONC	1	1	1	
43	67C-14398-00	WASHER RONDELLE	1	1	1	
44	67C-14325-00	SCREW, PAN HEAD VIS TETE CONIQUE	2	2	2	
45	67C-14245-00	SCREW, STOP VIS, BUTEE	1	1	1	
46	67C-14242-00	SPRING RESSORT	1	1	1	





67C1010-2080

**FIG. 8 OIL PUMP**

**POMPE A HUILE**

REF. NO.	PART NO. N° PIECES	DESCRIPTION DESCRIPTION	MHD	ED	ET	REMARKS REMARQUES
1	93102-37M40	OIL SEAL JOINT SPY	1	1	1	
2	67C-12171-00	CAMSHAFT 1 ARBRE A CAMES 1	1	1	1	
	67C-12170-11	CAMSHAFT ASSY 1 ENS ARBRE A CAMES 1	1			
3	67C-11537-01	GEAR, DRIVEN PIGNON SECONDAIRE	1	1	1	
4	93605-14143	PIN, DOWEL AXE	1	1	1	
5	90201-10M06	WASHER, PLATE RONDELLE, PLATE	1	1	1	
6	95895-10040	BOLT, FLANGE BOULON	1	1	1	
7	65W-46241-00	V-BELT COURROIE TRAPEZOIDALE	1	1	1	
8	65W-11536-10	GEAR, DRIVE ENGRENAGE, MENANT	1	1	1	
9	65W-11476-00	SPRING RESSORT	1	1	1	
10	90280-04M06	KEY, WOODRUFF CLAVETTE, DEMI-LUNE	1	1	1	
11	69W-13300-00	OIL PUMP ASSY POMPE A HUILE COMPLETE	1	1	1	
12	93210-33MH2	.O-RING JOINT TORIQUE	1	1	1	
13	93210-12MG9	.O-RING JOINT TORIQUE	1	1	1	
14	93210-14515	.O-RING JOINT TORIQUE	1	1	1	
15	90119-06025	BOLT, WITH WASHER BOULON, AVEC RONDELLE	4	4	4	

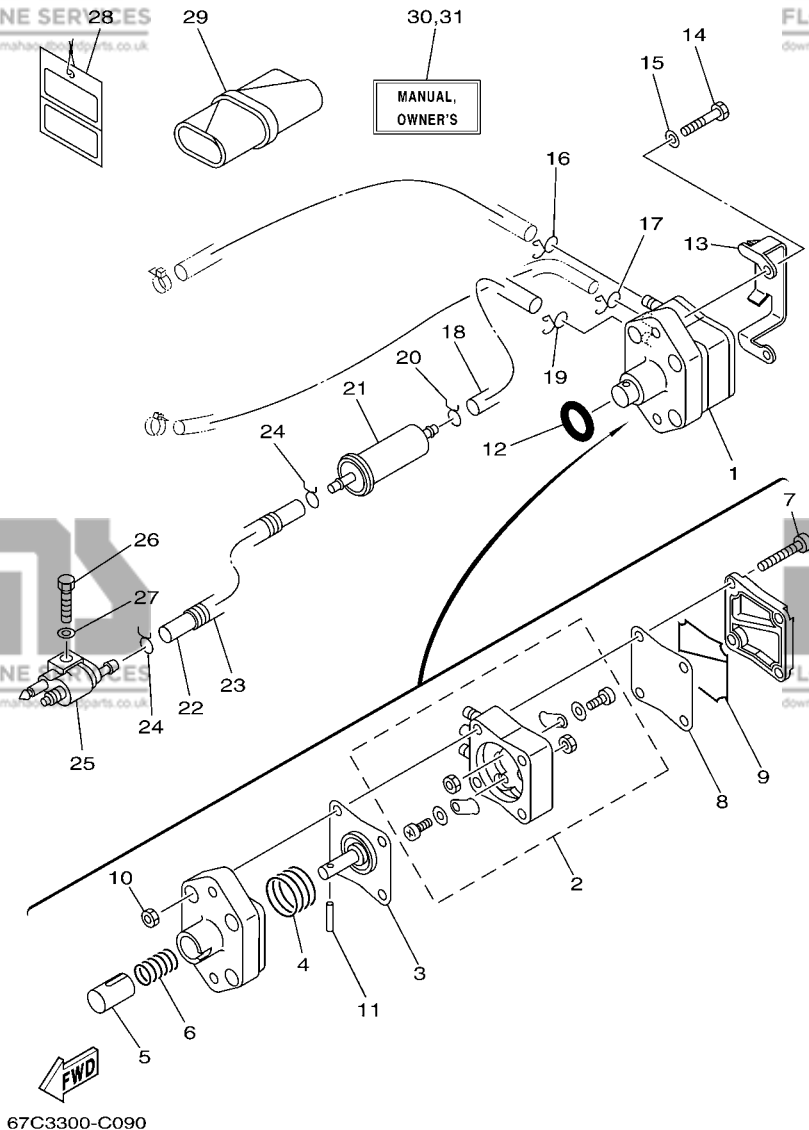
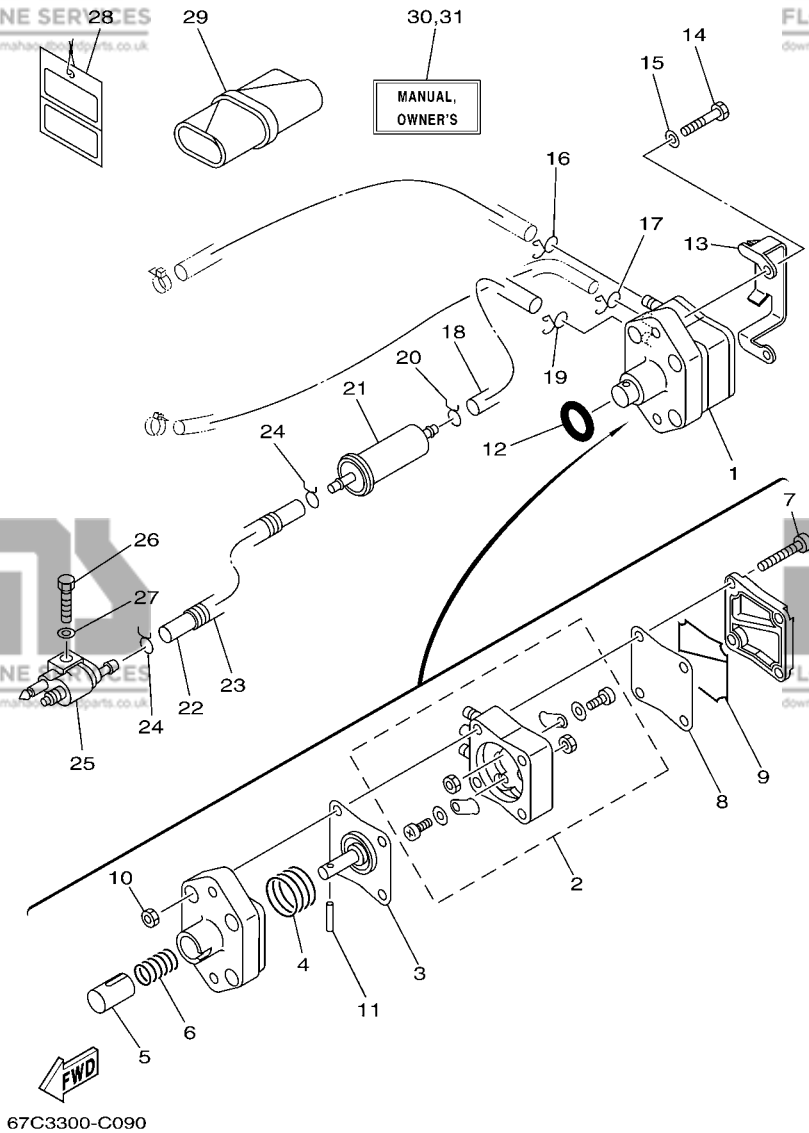


FIG. 9 FUEL

CARBURANT

REF. NO.	PART NO. N° PIECES	DESCRIPTION DESCRIPTION	MHD	ED	ET	REMARKS REMARQUES
1	62Y-24410-03	FUEL PUMP ASSY POMPE A ESSENCE	1	1	1	
2	62Y-24415-00	.PUMP BODY SUB ASSY .CORPS D' POMPE SUB COPM.	1	1	1	
3	62Y-24411-02	.DIAPHRAGM .DIAPHRAGME	1	1	1	
4	62Y-24423-00	.SPRING, DIAPHRAGM .RESSORT, DIAPHRAGME	1	1	1	
5	62Y-13131-01	.PLUNGER .PLONGEUR	1	1	1	
6	62Y-24454-00	.SPRING .RESSORT	1	1	1	
7	62Y-24444-01	.SCREW .VIS	4	4	4	
8	62Y-24471-00	.DIAPHRAGM .DIAPHRAGME	1	1	1	
9	62Y-24452-00	.PACKING .JOINT	1	1	1	
10	95380-05600	.NUT .ECROU	4	4	4	
11	62Y-24374-01	.PIN .PIN	1	1	1	
12	93210-24M79	O-RING JOINT TORIQUE	1	1	1	
13	65W-24474-00	COVER COUVERCLE	1	1	1	
14	97095-06030	BOLT BOULON	2	2	2	
15	92995-06600	WASHER RONDELLE	2	2	2	
16	90467-10M04	CLIP JONC	1	1	1	
17	90467-09M17	CLIP JONC	1	1	1	
18	90445-10MG6	HOSE (L180) DURITE (L180)	1	1	1	
19	90467-10M04	CLIP JONC	1	1	1	
20	90467-09M03	CLIP JONC	1	1	1	
21	65W-24251-00	STRAINER 1 FILTRE 1	1	1	1	
22	90445-10MH8	HOSE (L430) DURITE (L430)	1	1	1	
23	90446-14M12	HOSE DURITE	1	1	1	
24	90467-09M03	CLIP JONC	2	2	2	
25	6G1-24304-02	FUEL PIPE JOINT COMP. 1 DURITE RACCORDEMT. A ESSENCE	1	1	1	
26	97095-06025	BOLT BOULON	1	1	1	
27	92995-06600	WASHER RONDELLE	1	1	1	

C2

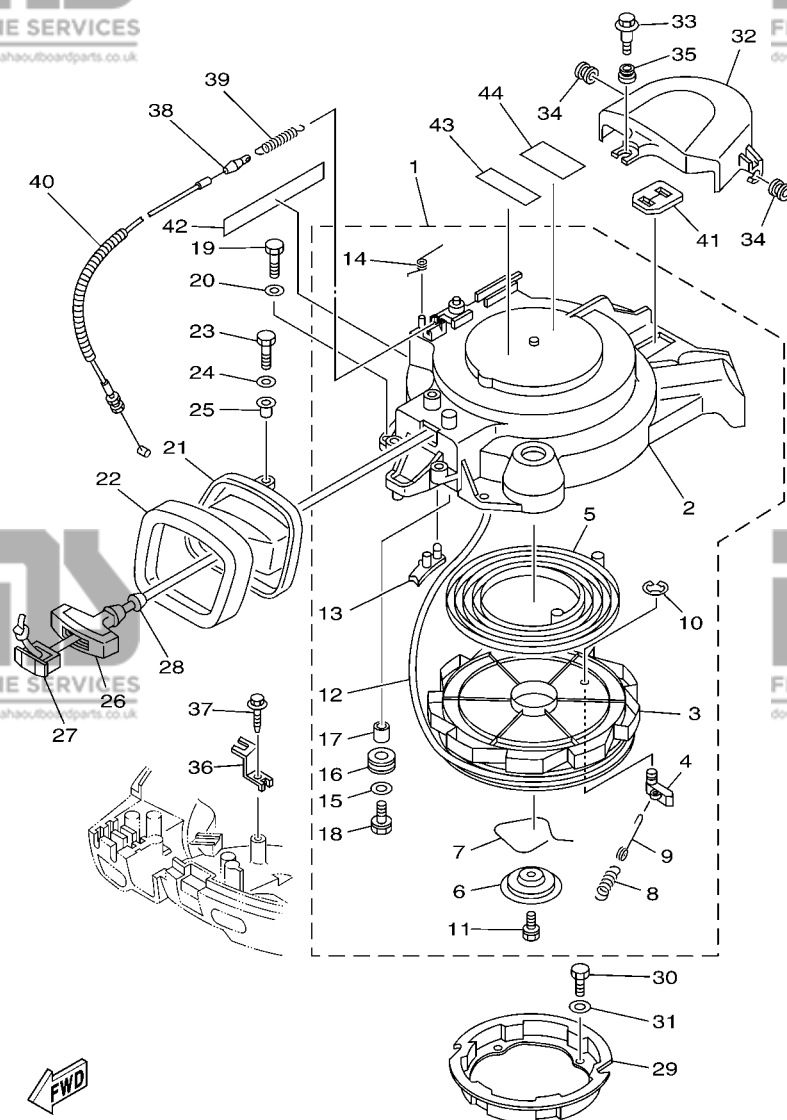


### FIG. 9 FUEL

### CARBURANT

REF. NO.	PART NO. N° PIECES	DESCRIPTION DESCRIPTION	MFD	ED	ET	REMARKS REMARQUES
28	61H-2819R-31	TAG, WARNING ETIQUETTE, AVERTISSEMENT	1	1	1	
29	62Y-28100-00	TOOL KIT TROUSSE A OUTILS	1	1	1	
30	67C-28199-74-A0	MANUAL, OWNER'S MANUEL D'UTILISATION	1	1	1	UR (E,FS) UR (E,FS)
	67C-28199-74-B0	MANUAL, OWNER'S MANUEL D'UTILISATION	1	1	1	UR (D,NL,I) UR (D,NL,I)
31	67C-28199-85-A0	MANUAL, OWNER'S MANUEL D'UTILISATION	1	1	1	UR (DK,P,GR) UR (DK,P,GR)
	67C-28199-85-B0	MANUAL, OWNER'S MANUEL D'UTILISATION	1	1	1	UR (N,S,SS) UR (N,S,SS)

**C3**



67C3300-C100

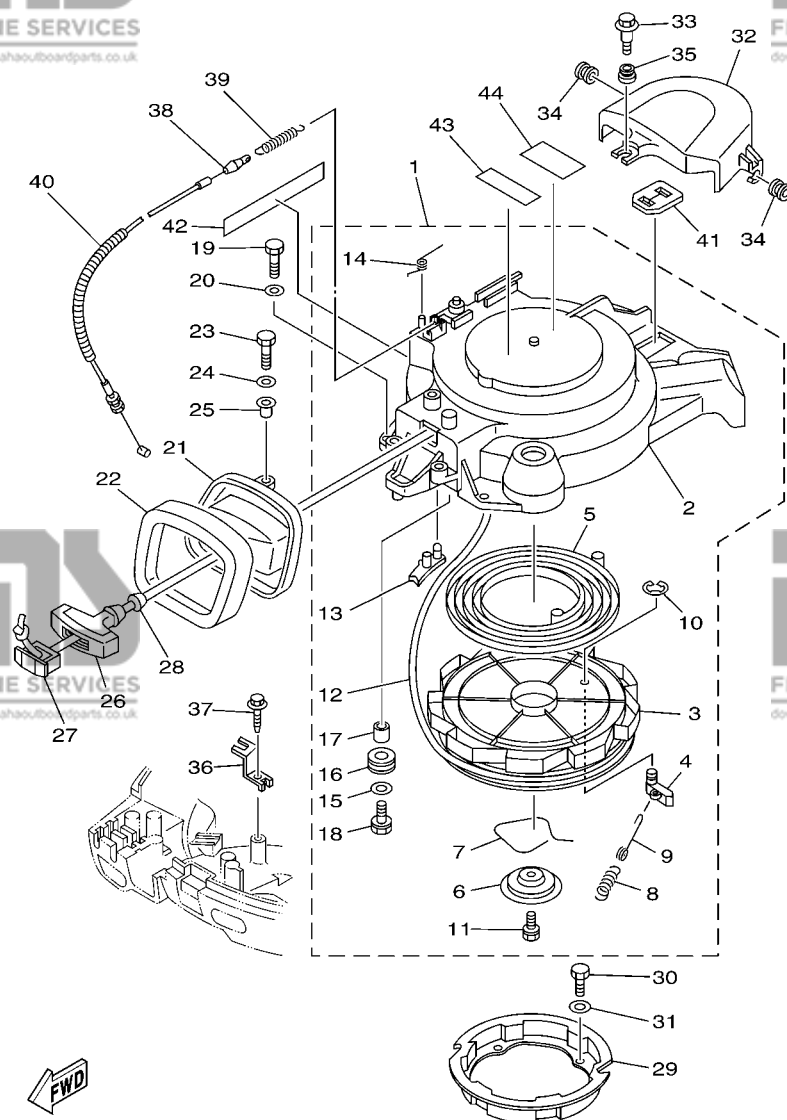
\*1: CUT FROM 50M ROLLS, PART NO. 90890-44374, CUTTING LENGTH 1.8M

\*1: A PRELEVER SUR BOBINE 50M ,REFERENCE 90890-44374, LONGUEUR DE COUPE 1.8M

**FIG. 10 STARTER**

**DEMARREUR**

REF. NO.	PART NO. N° PIECES	DESCRIPTION DESCRIPTION	MHD	ED	ET	REMARKS REMARQUES
1	67C-15710-00	STARTER ASSY DEMARREUR COMPLET	1			
2	67C-15711-00	.CASE, STARTER .CARTER DE DEMARREUR	1			
3	66T-15714-00	.DRUM, SHEAVE .TAMBOUR, POULIE	1			
4	63V-15741-00	.PAWL, DRIVE .CLIQUET, ENTRAINEMENT	1			
5	66T-15713-00	.SPRING, STARTER .RESSORT DE DEMARREUR	1			
6	66T-15716-00	.PLATE, DRIVE .PLAQUE, ENTRAINEMENT	1			
7	66T-15705-00	.SPRING, DRIVE PAWL .RESSORT DE CLIQUET	1			
8	66T-15767-00	.SPRING .RESSORT	1			
9	66T-15784-00	.SPRING, RETURN .RESSORT, RAPPEL	1			
10	63V-15744-00	.CIRCLIP .CIRCLIP	1			
11	63V-15768-00	.BOLT .BOULON	1			
12	*	.WIRE, STARTER (L:1800MM) .CABLE DE DEMARREUR (L:1800MM)	1			*1 *1
13	66T-15794-00	.STOPPER .BUTEE	1			
14	66T-15734-00	.SPRING, RETURN .RESSORT, RAPPEL	1			
15	6F5-15791-00	.WASHER, LOCK .RONDELLE-FREIN	1			
16	6F5-15752-00	.ROLLER, WIRE .GALET, CABLE	1			
17	6F5-15753-00	.BUSH .CHARBON	1			
18	97523-06425	.BOLT, WITH WASHER .VIS HEXAGONAL AVC RONDELLE	1			
19	97095-06025	BOLT BOULON	4			
20	92995-06600	WASHER RONDELLE	4			
21	67C-15758-00	GUIDE, ROPE GUIDE DE CABLE	1			
22	67C-15762-00	SEAL, RUBBER 2 JOINT CAOUTCHOUC 2	1			
23	97095-06025	BOLT BOULON	3			
24	92995-06600	WASHER RONDELLE	3			
25	90387-06M89	COLLAR COLLERETTE	3			
26	689-15755-01	HANDLE, STARTER POIGNEE, DE DEMARREUR	1			
27	6F5-15779-02	COVER COUVERCLE	1			



67C3300-C100

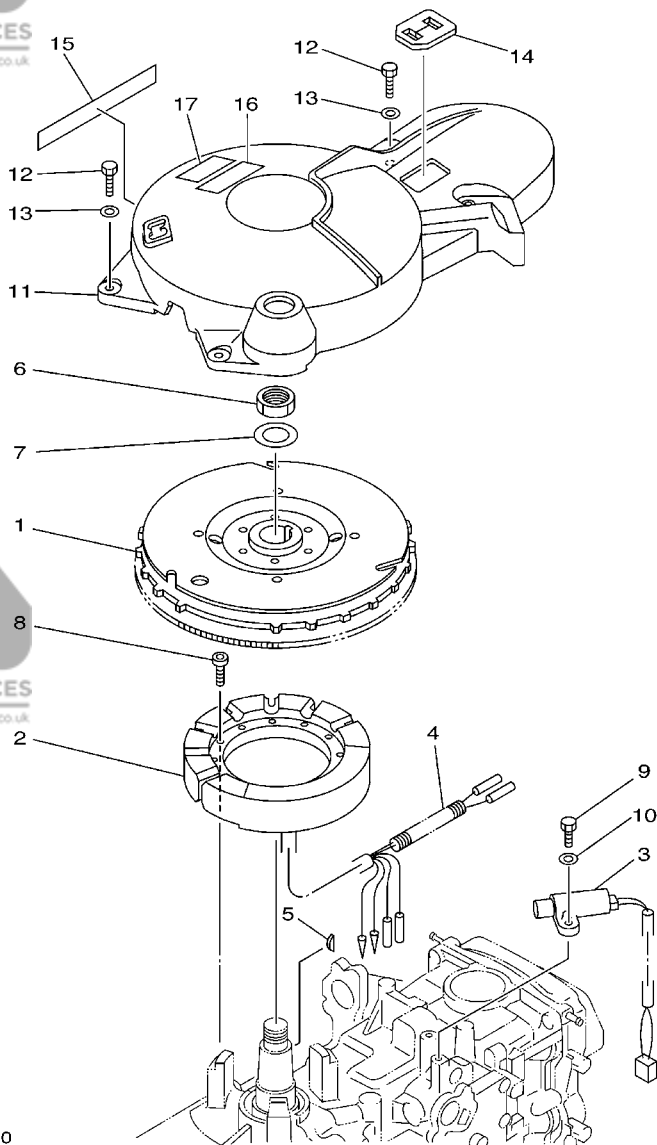
\*1: CUT FROM 50M ROLLS, PART NO. 90890-44374, CUTTING LENGTH 1.8M

\*1:A PRELEVER SUR BOBINE 50M ,REFERENCE 90890-44374, LONGUEUR DE COUPE 1.8M

**FIG. 10 STARTER**

**DEMARREUR**

REF. NO.	PART NO. N° PIECES	DESCRIPTION DESCRIPTION	MHD	ED	ET	REMARKS REMARQUES
28	6A0-15789-00	DAMPER AMORTISSEUR	1			
29	67C-15723-00	PULLEY, STARTER POULIE DE DEMARREUR	1			
30	97095-06010	BOLT BOULON	4			
31	92995-06600	WASHER RONDELLE	4			
32	67C-46297-00	COVER, DUST COUVERCLE, POUSSIERE	1			
33	90109-06MA1	BOLT BOULON	1			
34	90480-10M16	GROMMET PASSE-FIL	2			
35	90480-12072	GROMMET PASSE-FIL	1			
36	66M-15774-00	STAY 4 SUPPORT 4	1			
37	90109-06M86	BOLT BOULON	1			
38	67C-15770-00	CABLE COMP, STARTER STOP CABLE, BUTEE DE DEMAR	1			
39	66T-15731-00	SPRING, RETURN RESSORT, RAPPEL	1			
40	90446-10M86	HOSE DURITE	1			
41	65W-81639-10	PLATE, ARMATURE FITTING PLAQUE, FIXATION D'INDUIT	1			
42	62Y-13437-61	MARK, CAUTION MAKER	1			
43	6A1-83625-41	MARK 5 ETIQUETTE 5	1			
44	6A1-83625-51	MARK 5 ETIQUETTE 5	1			



67C1300-2110

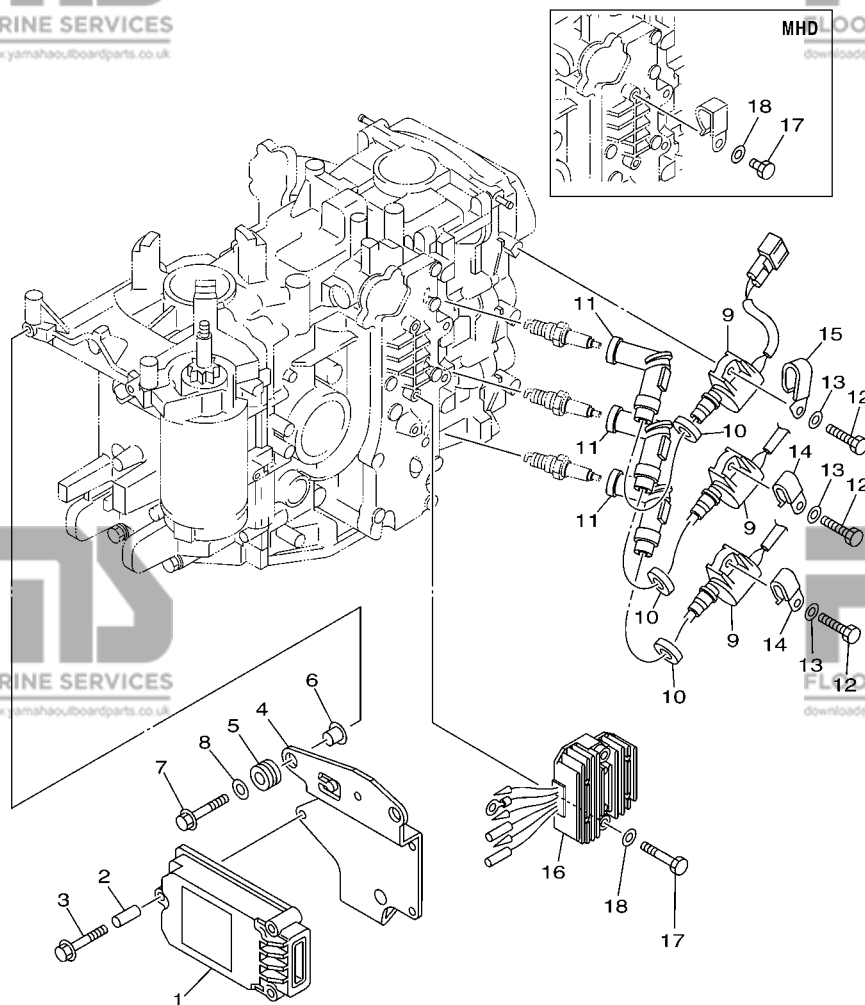
**FIG. 11 GENERATOR**

**GENERATRICE**

REF. NO.	PART NO. N° PIECES	DESCRIPTION DESCRIPTION	MHD	ED	ET	REMARKS REMARQUES
1	65W-85550-01	ROTOR ASSY ROTOR CPLT		1	1	
	65W-85550-11	ROTOR ASSY ROTOR CPLT	1			
2	65W-85510-10	STATOR ASSY STATOR CPLT		1	1	
	65W-85510-00	STATOR ASSY STATOR CPLT	1			
3	65W-85580-00	COIL, PULSER BOBINE, PULSEUR	1	1	1	
4	90446-10M82	HOSE (L90) DURITE (L90)	1	1	1	
5	65W-11545-00	KEY, WOODRUFF CLAVETTE, DEMI-LUNE	1	1	1	
6	90170-20137	NUT ECROU	1	1	1	
7	90201-21M18	WASHER, PLATE RONDELLE, PLATE	1	1	1	
8	91380-05030	BOLT BOULON		3	3	
	91380-05025	BOLT BOULON	3			
9	97095-05016	BOLT BOULON	2	2	2	
10	92995-05600	WASHER RONDELLE	2	2	2	
11	67C-81337-00	COVER, FLYWHEEL COUVERCLE, VOLANT	1	1		
12	97095-06025	BOLT BOULON	4	4		
13	92995-06600	WASHER RONDELLE	4	4		
14	65W-81639-10	PLATE, ARMATURE FITTING PLAQUE, FIXATION D'INDUIT	1	1		
15	62Y-13437-61	MARK, CAUTION MAKER	1	1		
16	6A1-83625-41	MARK 5 ETIQUETTE 5	1	1		
17	6A1-83625-51	MARK 5 ETIQUETTE 5	1	1		

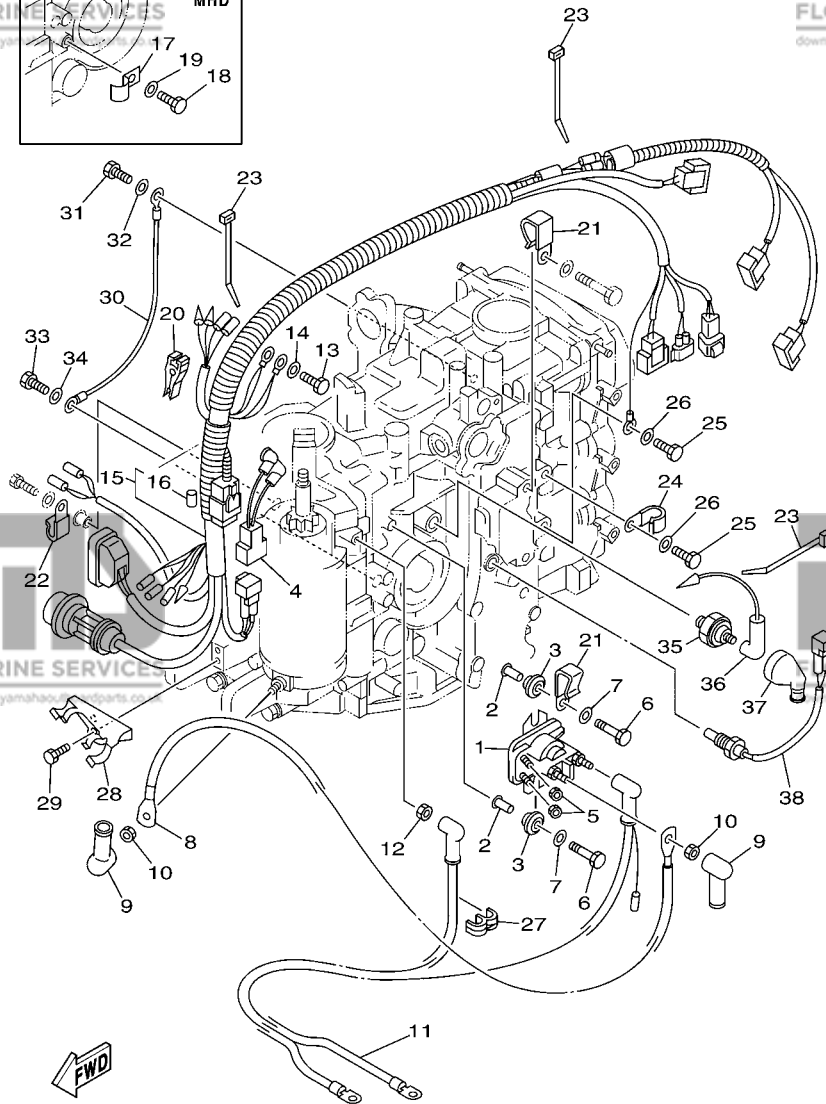
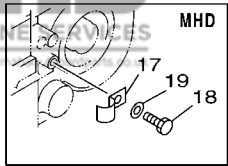
FIG. 12 ELECTRICAL 1

PARTIE ELECTRIQUE 1



67C3100-C130

REF. NO.	PART NO. N° PIECES	DESCRIPTION DESCRIPTION	MHD	ED	ET	REMARKS REMARQUES
1	67C-85540-01	C.D.I. UNIT ASSY BLOC C.D.I.	1	1	1	
2	65W-86129-00	COLLAR COLLERETTE	3	3	3	
3	65W-8252V-00	SCREW, SPECIAL VIS, SPECIALE	3	3	3	
4	67C-85542-00	BRACKET SUPPORT	1	1	1	
5	65W-85547-00	DAMPER AMORTISSEUR	3	3	3	
6	65W-86129-10	COLLAR COLLERETTE	3	3	3	
7	67C-8252V-00	BOLT, FLANGE (M6X25) BOULON, A COLLERETTE (M6X25)	3	3	3	
8	67C-85554-00	WASHER, ROTOR RONDELLE, ROTOR	3	3	3	
9	67C-85570-00	IGNITION COIL ASSY BOBINE D'ALLUMAGE (ENS.)	3	3	3	
10	90480-25161	GROMMET PASSE-FIL	3	3	3	
11	6G8-82370-30	PLUG CAP ASSY ANTIPARASITE	3	3	3	
12	97095-06020	BOLT BOULON	3	3	3	
13	92995-06600	WASHER RONDELLE	3	3	3	
14	90465-06M90	CLAMP BRIDE	2	2	2	
15	90465-06M88	CLAMP BRIDE	1	1	1	
16	65W-81960-10	RECTIFIER & REGULATOR ASSY REDRESSEUR REGULATEUR CPLT	1	1	1	
17	97095-06040	BOLT BOULON	2	2	2	
	97095-06012	BOLT BOULON	1			
18	92995-06600	WASHER RONDELLE	2	2	2	
	92995-06600	WASHER RONDELLE	1			



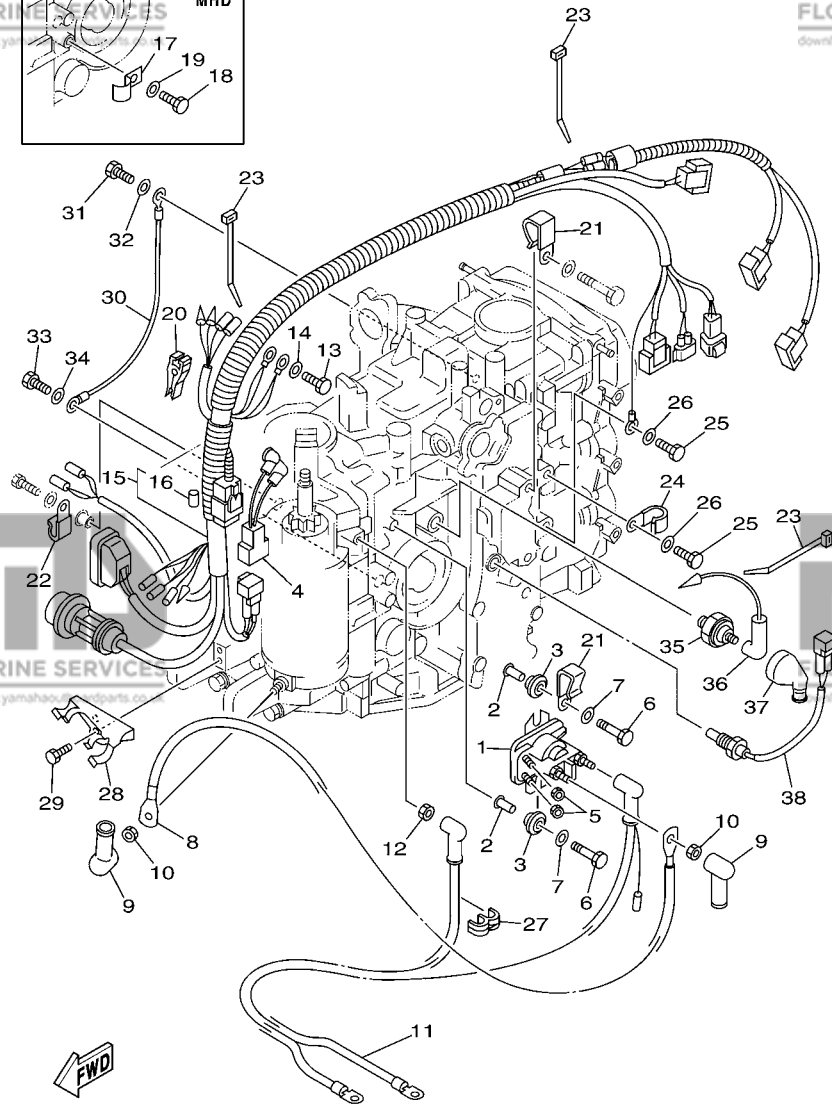
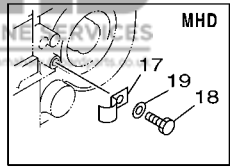
67C3100-C140

**FIG. 13 ELECTRICAL 2**

**PARTIE ELECTRIQUE 2**

REF. NO.	PART NO. N° PIECES	DESCRIPTION DESCRIPTION	MHD	ED	ET	REMARKS REMARQUES
1	65W-81941-00	STARTER RELAY ASSY LANCEUR RELAIS (ENS.)		1	1	
2	65W-8191C-00	COLLAR COLLERETTE		2	2	
3	65W-81922-00	GROMMET OUILLET CAOUTCHOUC		2	2	
4	67C-82509-00	WIRE, SUB LEAD FIL, SECONDAIRE		1	1	
5	65W-8182A-00	NUT ECROU		2	2	
6	97095-06030	BOLT BOULON		2	2	
7	92995-06600	WASHER RONDELLE		2	2	
8	65W-82117-00	WIRE, LEAD FIL		1	1	
9	6G5-82119-10	COVER, LEAD WIRE GARNITURE, FIL		2	2	
10	65W-8182B-00	NUT, SPECIAL ECROU, SPECIAL		2	2	
11	67C-82105-00	WIRE HARNESS FAISCEAU DE FILS		1	1	
12	65W-8182B-00	NUT, SPECIAL ECROU, SPECIAL		1	1	
13	97095-06012	BOLT BOULON		1	1	
14	92995-06600	WASHER RONDELLE		1	1	
15	67C-82590-20	WIRE HARNESS ASSY FAISCEAU DE FILS COMPLET			1	
	67C-82590-10	WIRE HARNESS ASSY FAISCEAU DE FILS COMPLET		1		
	67C-82590-00	WIRE HARNESS ASSY FAISCEAU DE FILS COMPLET		1		
16	67F-82151-00	.FUSE (20A) .FUSIBLE (20A)		2	2	
17	90465-08M63	CLAMP BRIDE		1		
18	97095-06012	BOLT BOULON		1		
19	92995-06600	WASHER RONDELLE		1		
20	67F-2812A-00	PULLER, FUSE TENDEUR, FUSIBLE		1	1	
21	90465-05M87	CLAMP BRIDE		2	2	
22	90465-06M90	CLAMP BRIDE		1	1	
23	90465-13M18	CLAMP BRIDE		3	3	
24	90465-08M75	CLAMP BRIDE		1	1	
25	97095-06012	BOLT BOULON		3	3	





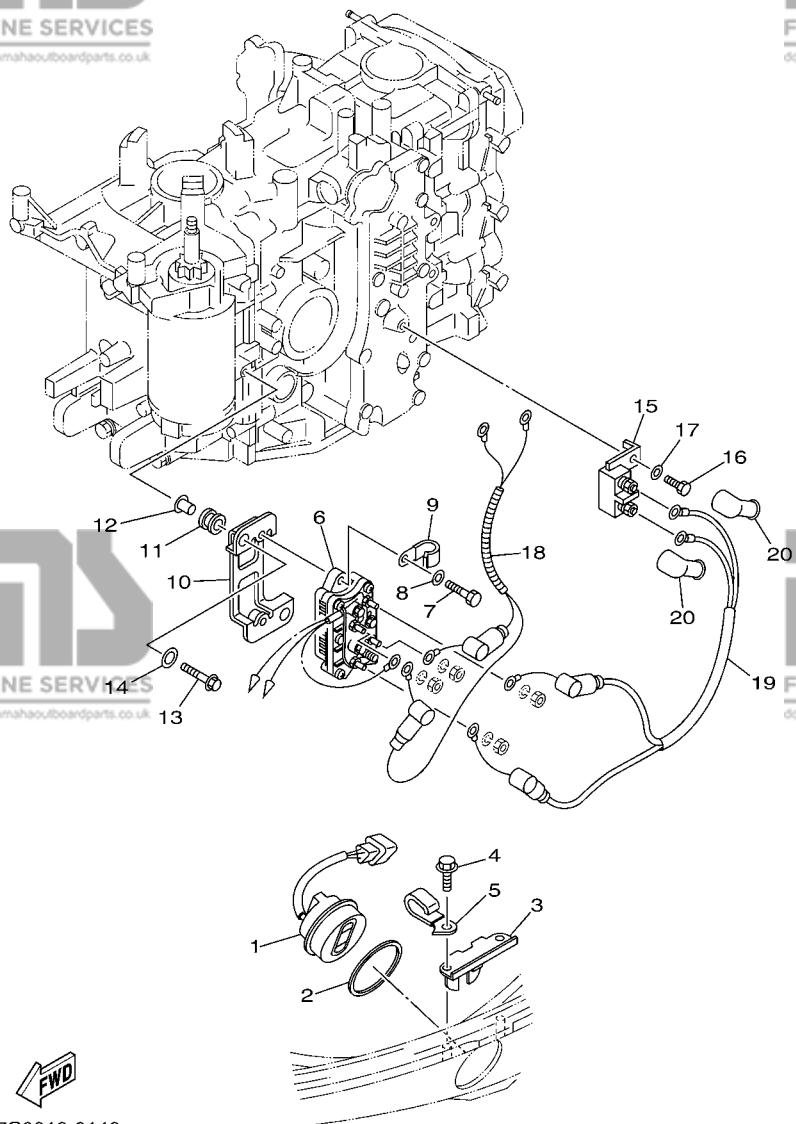
67C3100-C140

**FIG. 13 ELECTRICAL 2**

**PARTIE ELECTRIQUE 2**

REF. NO.	PART NO. N° PIECES	DESCRIPTION DESCRIPTION	MHD	ED	ET	REMARKS REMARQUES
26	92995-06600	WASHER RONDELLE	3	3	3	
27	90464-10M57	CLAMP BRIDE		1	1	
28	67C-82594-00	CLAMP BRIDE		1	1	
29	97095-05012	BOLT BOULON		2	2	
30	67C-82519-00	WIRE, EARTH LEAD FIL, MASSE	1	1	1	
31	97095-08012	BOLT BOULON	1	1	1	
32	92995-08600	WASHER RONDELLE	1	1	1	
33	97095-06012	BOLT BOULON	1	1	1	
34	92995-06600	WASHER RONDELLE	1	1	1	
35	65W-82504-00	OIL PRESSURE SWITCH ASSY CONTACTEUR DE PRESSION D'HUILE	1	1	1	
36	65W-82127-00	WIRE, LEAD 2 FIL 2	1	1	1	
37	65W-82532-00	CAP COUVERCLE	1	1	1	
38	67C-85790-00	THERMOSENSOR ASSY SENSITOMETRE	1	1	1	

**D2**



67C0010-0140

**FIG. 14 ELECTRICAL 3**

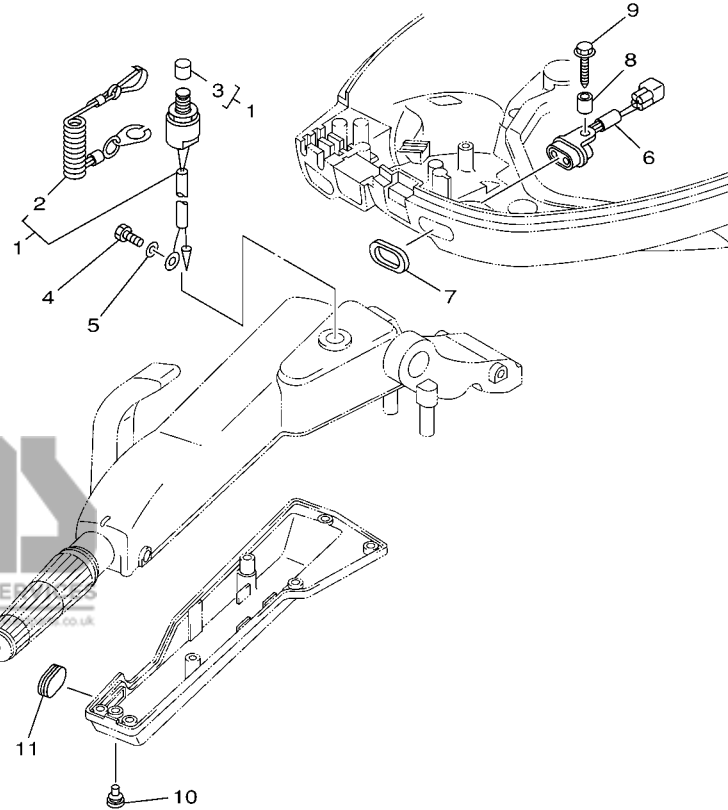
**PARTIE ELECTRIQUE 3**

REF. NO.	PART NO. N° PIECES	DESCRIPTION DESCRIPTION	MHD	ED	ET	REMARKS REMARQUES
1	63D-82563-10	TRIM & TILT SWITCH ASSY INCLINER ET PARER COMMUTATEUR			1	
2	6E5-82587-00	GASKET JOINT			1	
3	62Y-83614-00	BRACKET SUPPORT			1	
4	90109-06M86	BOLT BOULON			2	
5	90465-06M88	CLAMP BRIDE			1	
6	6H1-81950-00	RELAY ASSY RELAIS COMPLET			1	
7	97095-06020	BOLT BOULON			2	
8	92995-06600	WASHER RONDELLE			2	
9	90465-08M75	CLAMP BRIDE			1	
10	67C-81948-00	BRACKET JOINT TORIQUE			1	
11	6A0-82317-00	DAMPER, IGNITION COIL AMORTISSEUR, BOBINE D'ALLUM			2	
12	624-42542-00	PIPE TUYAU			2	
13	95895-06030	BOLT, FLANGE BOULON			2	
14	90201-12M16	WASHER, PLATE RONDELLE, PLATE			2	
15	6H5-81920-00	TERMINAL ASSY BORNE			1	
16	97095-06012	BOLT BOULON			1	
17	92995-06600	WASHER RONDELLE			1	
18	67C-81949-00	WIRE, LEAD FIL			1	
19	67C-81949-10	WIRE, LEAD FIL			1	
20	6G5-82119-00	COVER, LEAD WIRE GARNITURE, FIL			2	

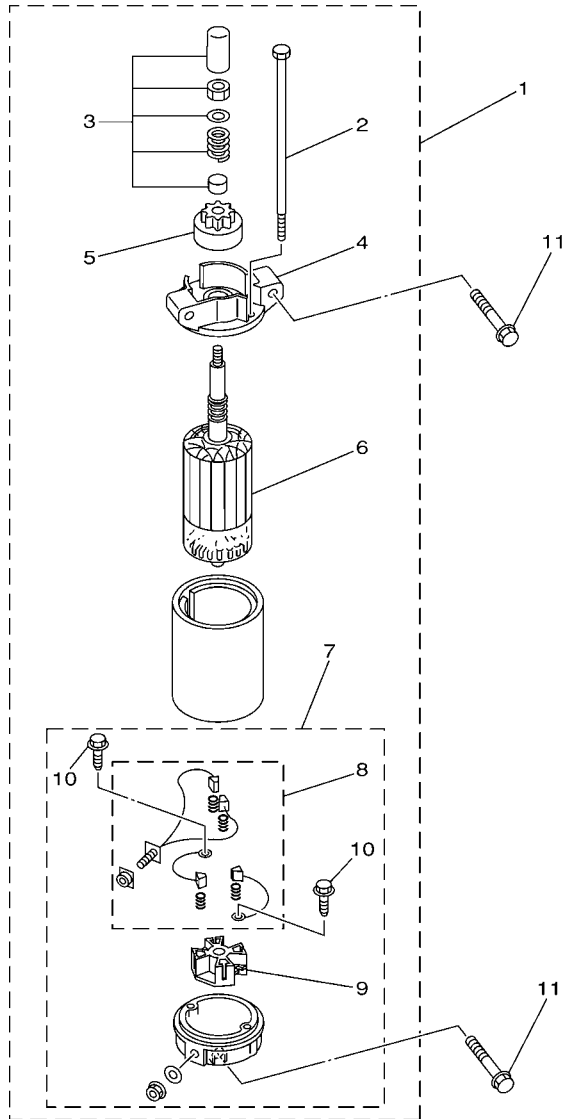
FIG. 15 ELECTRICAL 4

PARTIE ELECTRIQUE 4

REF. NO.	PART NO. N° PIECES	DESCRIPTION DESCRIPTION	MFD	ED	ET	REMARKS REMARQUES
1	6K5-82575-03	ENGINE STOP SWITCH ASSY COUPE CIRCUIT CPLT	1			
2	682-82556-00	.STOPPER .PLAQUETTE	1			
3	689-8257Y-00	.CAP .CHAPEAU	1			
4	97095-06012	BOLT BOULON	1			
5	92995-06600	WASHER RONDELLE	1			
6	62Y-84301-00	PILOT LIGHT ASSY 1 LAMPE-TEMOIN 1	1			
7	6H4-83589-00	GASKET GARNITURE	1			
8	90387-06M87	COLLAR COLLERETTE	1			
9	90109-06MA2	BOLT BOULON	1			
10	90480-06M19	GROMMET PASSE-FIL	2			
11	67C-42726-00	GROMMET PASSE-FIL	1			



67C0100-0160

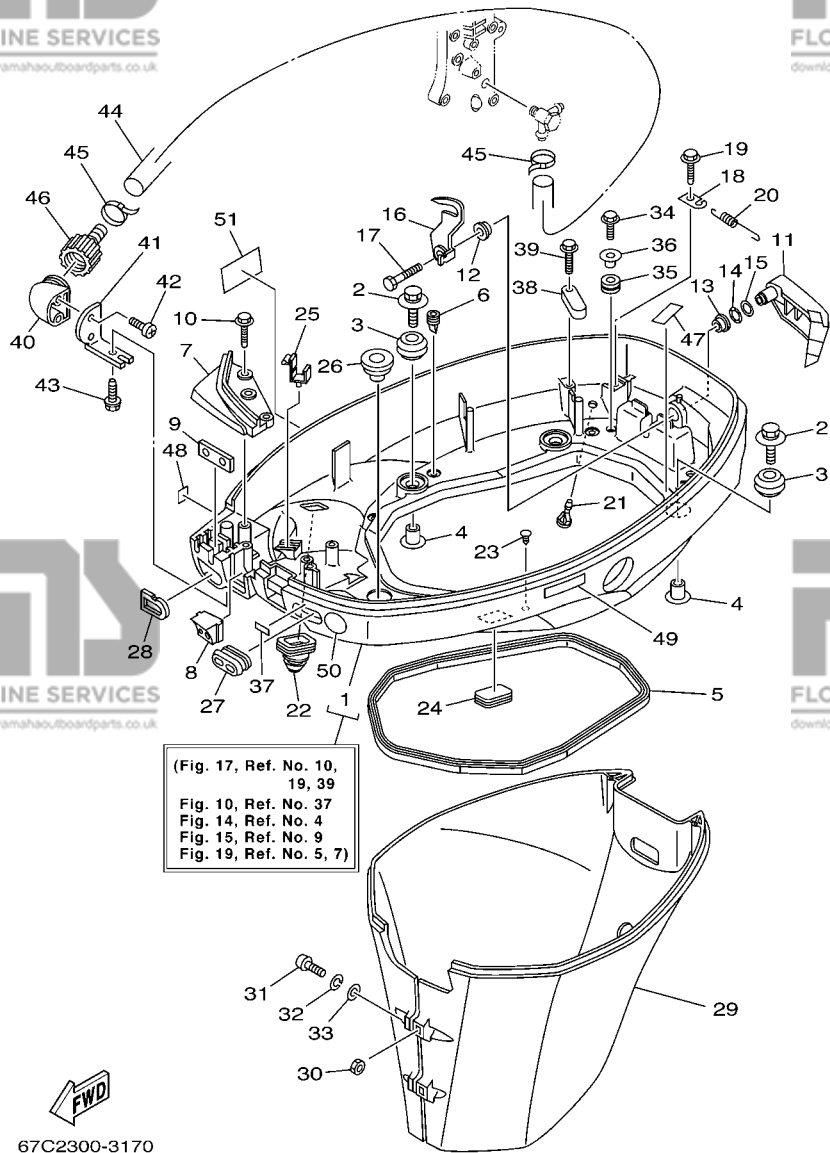


67C0010-0160

**FIG. 16 STARTING MOTOR**

**DEMARREUR ELECTRIQUE**

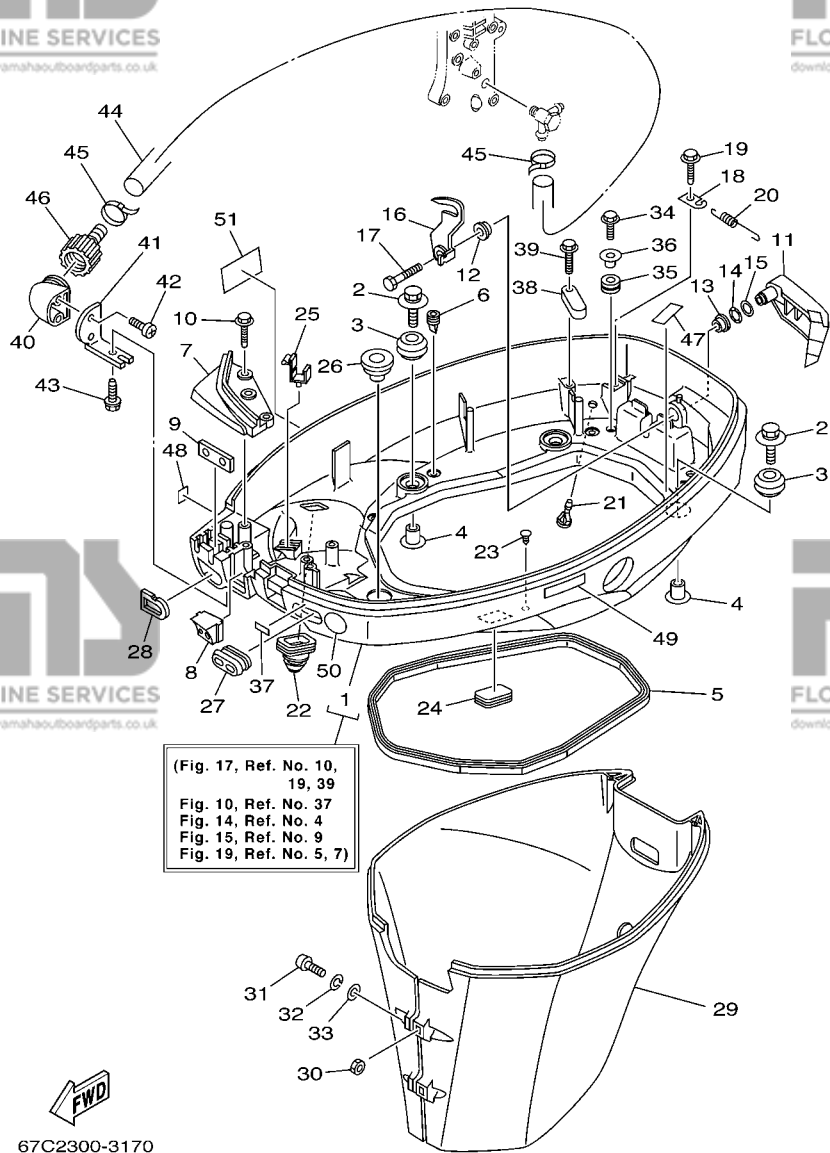
REF. NO.	PART NO. N° PIECES	DESCRIPTION DESCRIPTION	MFD	ED	ET	REMARKS REMARQUES
1	67C-81800-00	STARTING MOTOR ASSY DEMARREUR ELECTRIQUE COMPLET		1	1	
2	67C-81826-00	.BOLT .BOULON		2	2	
3	65W-81857-01	.RETAINER .ARRETOIR		1	1	
4	65W-81830-00	.FRONT BRACKET ASSY .SUPPORT AVANT		1	1	
5	65W-81807-00	.GEAR ASSY, STARTING MOTOR .PIGNON, DEMARREUR ELECTRIQUE		1	1	
6	67C-81850-00	.ARMATURE ASSY .INDUIT		1	1	
7	65W-81820-00	.REAR BRACKET ASSY .SUPPORT ARRIERE COMPLET		1	1	
8	65W-81801-00	..BRUSH SET ..CHARBON		1	1	
9	65W-81840-00	..BRUSH HOLDER ASSY ..SUPPORT DE CHARBON		1	1	
10	65W-8182S-00	..SCREW ..VIS		2	2	
11	90119-08M39	BOLT, WITH WASHER BOULON, AVEC RONDELLE		3	3	



**FIG. 17 BOTTOM COWLING**

**CAPOT INFERIEUR**

REF. NO.	PART NO. N° PIECES	DESCRIPTION DESCRIPTION	MHD	ED	ET	REMARKS REMARQUES
1	67C-42710-12-4D	BOTTOM COWLING ASSY ENS. EMBASE			1	WITH TAPPING BOLT WITH TAPPING BOLT
	67C-42710-02-4D	BOTTOM COWLING ASSY ENS. EMBASE	1	1		WITH TAPPING BOLT WITH TAPPING BOLT
2	90119-06M08	BOLT, WITH WASHER BOULON, AVEC RONDELLE	4	4	4	
3	90480-09M12	GROMMET PASSE-FIL	4	4	4	
4	90387-06060	COLLAR COLLERETTE	4	4	4	
5	62Y-42716-00	RUBBER, SEAL 1 JOINT EN CAOUTCHOUC 1	1	1	1	
6	65W-42717-00	RUBBER, SEAL 2 JOINT EN CAOUTCHOUC 2	4	4	4	
7	67C-42738-00-4D	PLATE, FITTING ETRIER	1	1	1	
8	62Y-42725-30	GROMMET PASSE-FIL			1	
	62Y-42725-00	GROMMET PASSE-FIL			1	
	67C-42725-00	GROMMET PASSE-FIL	1			
9	62Y-42727-00	GROMMET PASSE-FIL	1	1	1	
10	90109-06M81	BOLT BOULON	3	3	3	
11	67C-42815-00-4D	LEVER, CLAMP LEVIER, PRESSE	1	1	1	
12	90386-12M37	BUSH DOUILLE	1	1	1	
13	90386-12MA2	BUSH DOUILLE	1	1	1	
14	90206-12052	WASHER, WAVE RONDELLE, ONDULEE	1	1	1	
15	90201-12M07	WASHER, PLATE RONDELLE, PLATE	1	1	1	
16	67C-42816-01	LEVER, CLAMP LEVIER, PRESSE	1	1	1	
17	97095-06012	BOLT BOULON	1	1	1	
18	66T-43144-00	HOOK, SPRING CROCHET	1	1	1	
19	90109-06M86	BOLT BOULON	1	1	1	
20	90506-18M40	SPRING, TENSION RESSORT, TENSION	1	1	1	
21	6H3-44391-01	NIPPLE, HOSE RACCORD D'ESSENCE	1	1	1	
22	6H1-42726-21	GROMMET PASSE-FIL			1	FLUSHING KIT FLUSHING KIT
	65W-42724-10	GROMMET PASSE-FIL	1	1		FLUSHING KIT FLUSHING KIT
23	90338-07004	PLUG PLOT	1	1	1	



**FIG. 17 BOTTOM COWLING**

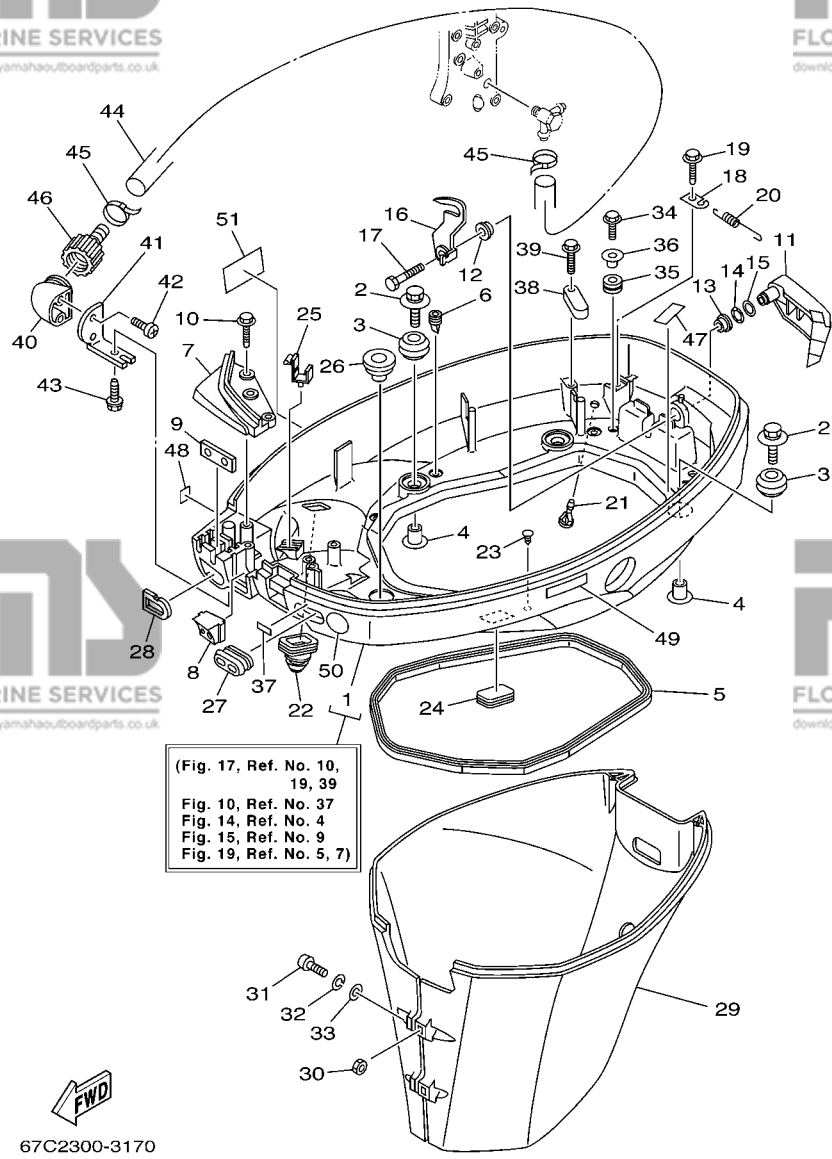
**CAPOT INFERIEUR**

REF. NO.	PART NO. N° PIECES	DESCRIPTION DESCRIPTION	MFD	ED	ET	REMARKS REMARQUES
24	6H4-42726-00	GROMMET PASSE-FIL	1	1	1	FLUSHING KIT FLUSHING KIT
25	90464-09M13	CLAMP BRIDE	1	1	1	
26	676-42727-00	GROMMET PASSE-FIL	1	1	1	
27	6H3-42727-00	GROMMET PASSE-FIL		1	1	
28	61N-24329-00	SEAL JOINT	1	1	1	
29	67C-42741-00-4D	APRON CAPOT LATERAL	1		1	S S L L
	67C-42741-10-4D	APRON CAPOT LATERAL	1	1	1	
30	95380-06600	NUT, HEXAGON ECROU	2	2	2	
31	97880-06025	SCREW, PAN HEAD VIS, TETE TRONCONIQUE	2	2	2	
32	92990-06100	WASHER, SPRING RONDELLE, GROWER	2	2	2	
33	92990-06600	WASHER, PLATE RONDELLE, PLATE	2	2	2	
34	90109-06M80	BOLT BOULON	2	2	2	
35	90480-13M24	GROMMET PASSE-FIL	2	2	2	
36	90387-06M43	COLLAR COLLERETTE	2	2	2	
37	67C-85415-00	MARK, SIGNAL LAMP ETIQUETTE	1			
38	6E5-82588-00	PLATE PLAQUE	1	1	1	
39	90109-06M81	BOLT BOULON	1	1	1	
40	68T-12572-00	ADAPTER ADAPTATEUR	1	1	1	FLUSHING KIT FLUSHING KIT
41	69W-12535-00	PLATE PLAQUE	1	1	1	FLUSHING KIT FLUSHING KIT
42	90167-06002	SCREW, TAPPING VIS, TETE FRAISEE	2	2	2	FLUSHING KIT FLUSHING KIT
43	90109-06M80	BOLT BOULON	1	1	1	FLUSHING KIT FLUSHING KIT
44	67C-24312-00	PIPE 2 DURITE 2	1	1	1	FLUSHING KIT FLUSHING KIT
45	90465-11M10	CLAMP BRIDE	2	2	2	FLUSHING KIT FLUSHING KIT
46	6R3-12580-00	JOINT ASSY ARTICULER (ENS.)	1	1	1	FLUSHING KIT FLUSHING KIT
47	62Y-82377-00	LABEL ETIQUETTE	1	1	1	
48	6A1-28176-00	LABEL, CAUTION ETIQUETTE, RECOMMANDATION	1	1	1	
49	6E3-8257H-00	PLATE, MARK PLAQUE, ADHESIF	1	1	1	

**FIG. 17 BOTTOM COWLING**

**CAPOT INFERIEUR**

REF. NO.	PART NO. N° PIECES	DESCRIPTION DESCRIPTION	MFD	ED	ET	REMARKS REMARQUES
50	6G8-2415E-00	LABEL, CAUTION EMBLEME, RECOMMANDATION	1	1	1	FOR SAV FOR SAV
51	62Y-13444-50	MARK MAKER	1	1	1	

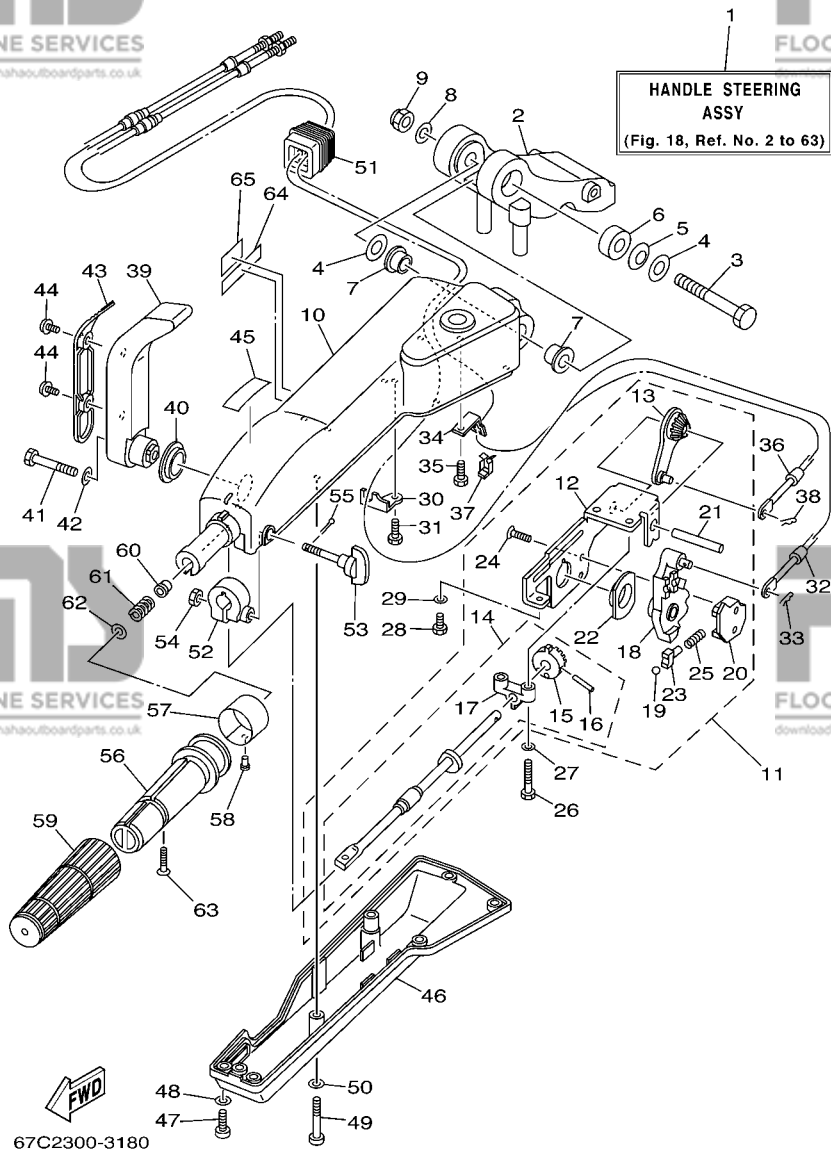


(Fig. 17, Ref. No. 10, 19, 39  
Fig. 10, Ref. No. 37  
Fig. 14, Ref. No. 4  
Fig. 15, Ref. No. 9  
Fig. 19, Ref. No. 5, 7)

**FWD**  
67C2300-3170

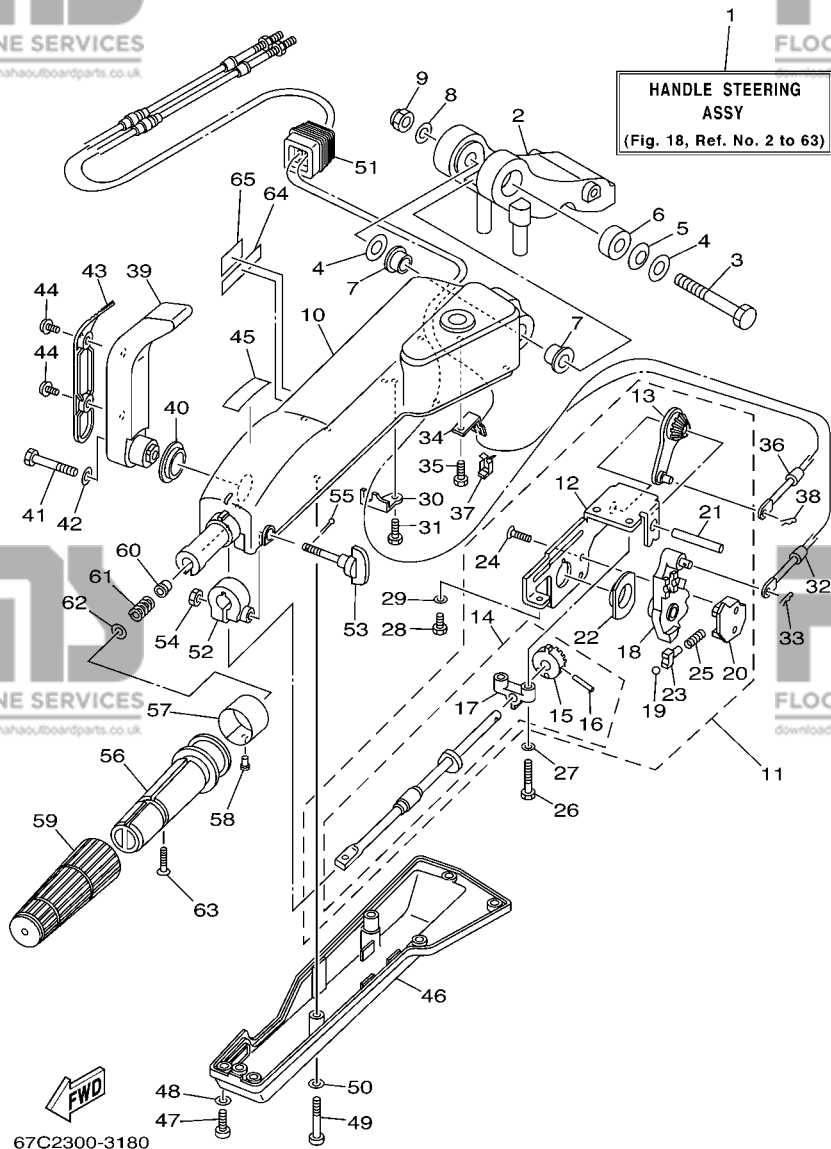
**FIG. 18 STEERING**

**DIRECTION**



REF. NO.	PART NO. N° PIECES	DESCRIPTION DESCRIPTION	MHD	ED	ET	REMARKS REMARQUES
1	69W-W0084-10-4D	HANDLE STEERING ASSY BARRE FRANCHE (ENS.)	1			
2	63D-42121-20-4D	BRACKET SUPPORT	1			
3	90101-12M09	BOLT BOULON	1			
4	92990-12200	WASHER, PLAIN RONDELLE, PLATE	2			
5	90206-12M22	WASHER, WAVE RONDELLE, ONDULEE	1			
6	90387-12M02	COLLAR COLLERETTE	1			
7	90386-12M93	BUSH DOUILLE	2			
8	92990-12600	WASHER, PLATE RONDELLE, PLATE	1			
9	90185-12M12	NUT, SELF-LOCKING ECROU, AUTO-BLOCANT	1			
10	67G-42111-00-4D	HANDLE, STEERING POIGNEE	1			
11	69W-44100-10	SHIFT LINK ASSY MAILLON DE SELECTEUR	1			
12	67C-44104-00	.PLATE COMP. .PLAQUE COMPLET	1			
13	69W-48261-00	.ARM, THROTTLE .BRAS, ACCELERATION	1			
14	69W-42115-10	.SHAFT, STEERING HANDLE .AXE, BARRE FRANCHE	1			
15	650-42152-00-94	..GEAR ..PIGNON	1			
16	91690-30025	..PIN, SPRING ..AGRAFFE	1			
17	67G-42159-00	..STAY ..SUPPORT	1			
18	67C-44113-00	.CAM PLATE, HANDLE .CAME, VERROUILLAGE	1			
19	63D-48236-00	.ROLLER, DETENT .POULIE	1			
20	67C-48119-00	.COVER .COUILLE	1			
21	67G-42153-00	.SHAFT, THROTTLE CONTROL .AXE, COMMANDE D'ACCELERATION	1			
22	67G-44132-00	.BUSHING .COUSSINET	1			
23	63D-48237-00	.ADAPTOR .ADAPTEUR	1			
24	98785-05014	.SCREW, FLAT HEAD .VIS, TETE PLATE	2			
25	63D-48238-00	.SPRING, DETENT ..RESSORT	1			
26	97095-06030	BOLT BOULON	2			
27	92995-06600	WASHER RONDELLE	2			

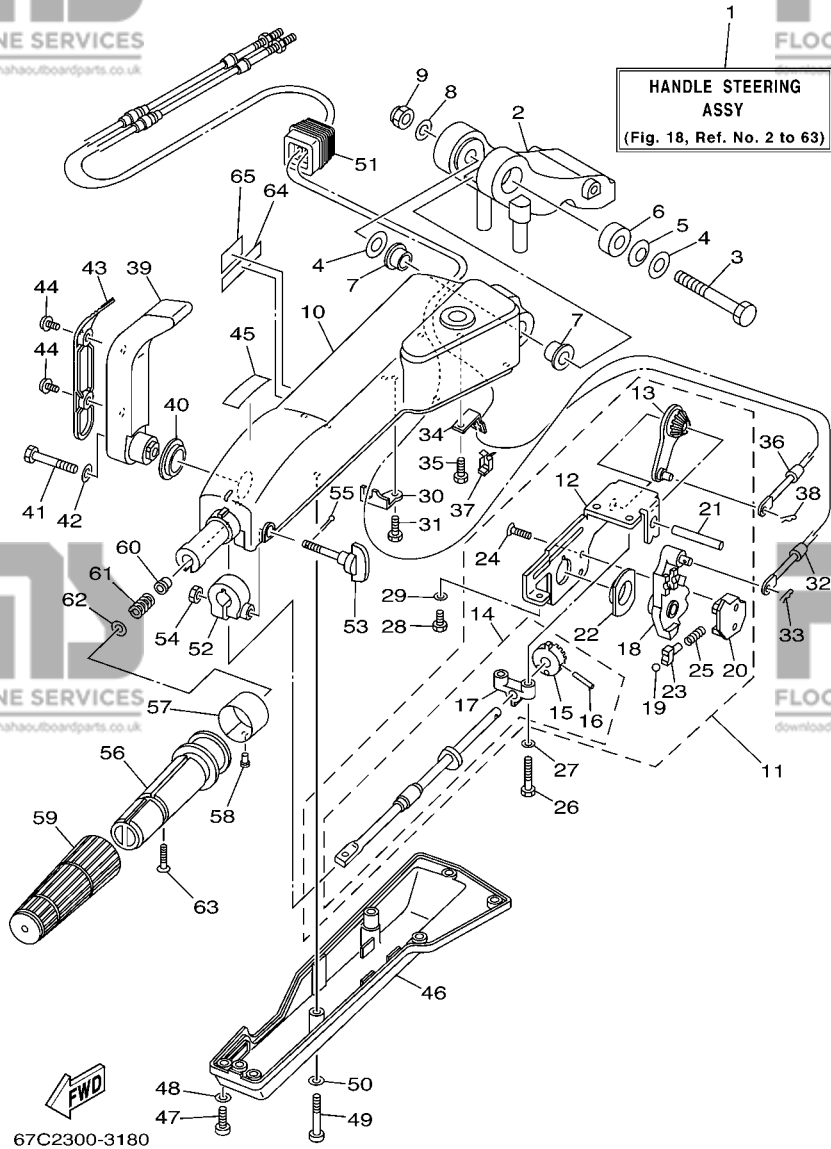




**FIG. 18 STEERING**

**DIRECTION**

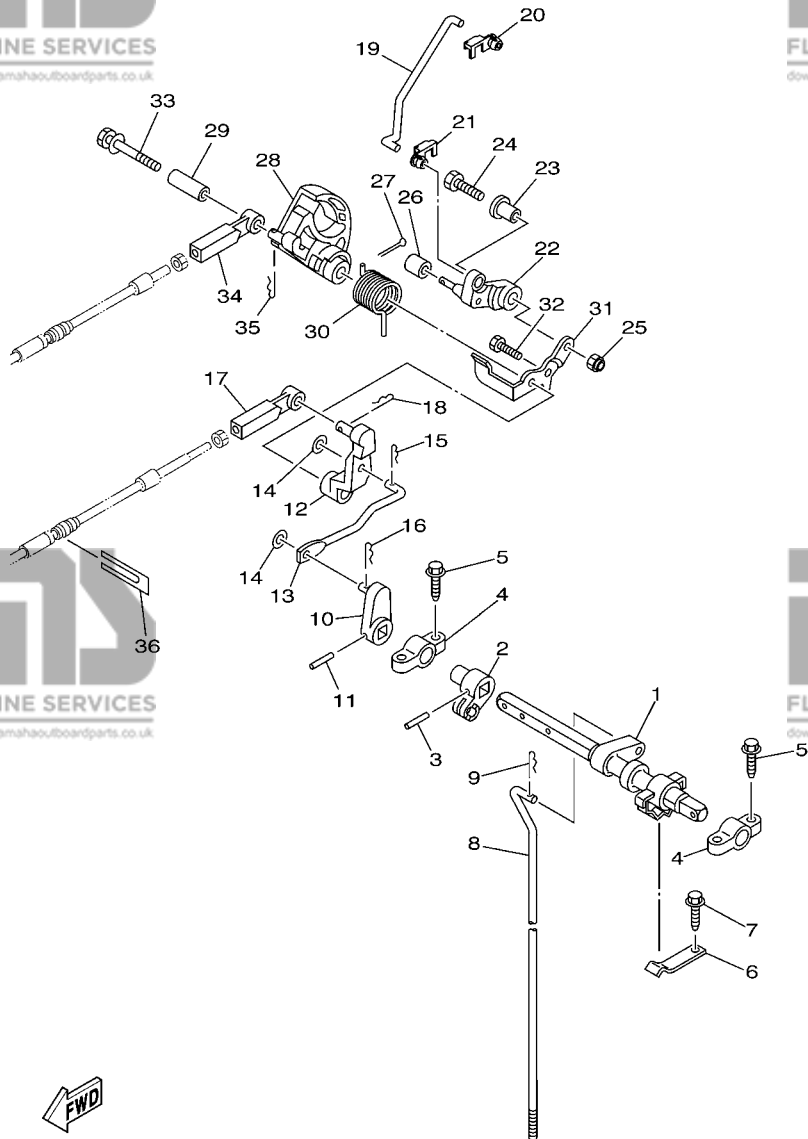
REF. NO.	PART NO. N° PIECES	DESCRIPTION DESCRIPTION	MFD	ED	ET	REMARKS REMARQUES
28	97095-06014	BOLT BOULON	1			
29	92995-06600	WASHER RONDELLE	1			
30	67G-48531-00	BRACKET, REMOTE CONTROL 1 ETRIER 1, COMMANDE A DISTANCE	1			
31	97095-06014	BOLT BOULON	1			
32	67C-48321-00	CABLE CABLE	1			
33	90468-10005	CLIP JONC	1			
34	69W-48538-00	CLAMP, CABLE 1 COLLIER	1			
35	97095-06014	BOLT BOULON	1			
36	69W-26301-00	THROTTLE CABLE ASSY CABLE D'ACCELERATEUR	1			
37	63D-48538-00	CLAMP, CABLE 1 COLLIER	1			
38	90468-10005	CLIP JONC	1			
39	67G-44159-00-4D	HANDLE, GEAR SHIFT POIGNEE, LEVIER D'EMBRAYAGE	1			
40	90386-26MA3	BUSH DOUILLE	1			
41	97095-08040	BOLT BOULON	1			
42	92995-08600	WASHER RONDELLE	1			
43	67G-44173-00	LEVER, SHIFT CONTROL POIGNEE, INVERSION	1			
44	90159-06M18	SCREW, WITH WASHER VIS, AVEC RONDELLE	2			
45	6G8-44191-00	INDICATOR, SHIFT ETIQUETTE, EMBRAYAGE	1			
46	67G-42131-00	COVER, HANDLE STEERING COUVERCLE	1			
47	97885-06016	SCREW, PAN HEAD VIS, A ENCOCHE	5			
48	92995-06600	WASHER RONDELLE	5			
49	97885-06040	SCREW, PAN HEAD VIS, A ENCOCHE	2			
50	92995-06600	WASHER RONDELLE	2			
51	63D-42725-00	GROMMET PASSE-FIL	1			
52	63D-42126-00	FRICTION, STEERING HANDLE GRIP CUVETTE, POIGNEE DE DIRECTION	1			
53	63D-48154-00	KNOB, THROTTLE BOUTON, ACCELERATEUR	1			
54	95380-06600	NUT, HEXAGON ECROU	1			



**FIG. 18 STEERING**

**DIRECTION**

REF. NO.	PART NO. N° PIECES	DESCRIPTION DESCRIPTION	MFD	ED	ET	REMARKS REMARQUES
55	91490-20010	PIN, COTTER GOUILLE	1			
56	69W-42119-00	GRIP, STEERING HANDLE POIGNEE, BARRE FRANCHE	1			
57	6J0-42137-00	INDICATOR, THROTTLE INDICATEUR, ACCELERATION	1			
58	90269-02M09	RIVET RIVET	1			
59	6G1-42177-00	RUBBER, HANDLE CAOUTCHOUC, POIGNEE	1			
60	90386-08032	BUSH DOUILLE	1			
61	90501-23215	SPRING, COMPRESSION RESSORT, COMPRESSION	1			
62	92903-10600	WASHER, PLATE RONDELLE, PLATE	1			
63	90149-05M13	SCREW VIS	1			
64	6E0-83627-41	LABEL, CAUTION 7 ETIQUETTE, RECOMMANDATION 7	1			
65	6E0-83627-51	LABEL, CAUTION 7 ETIQUETTE, RECOMMANDATION 7	1			

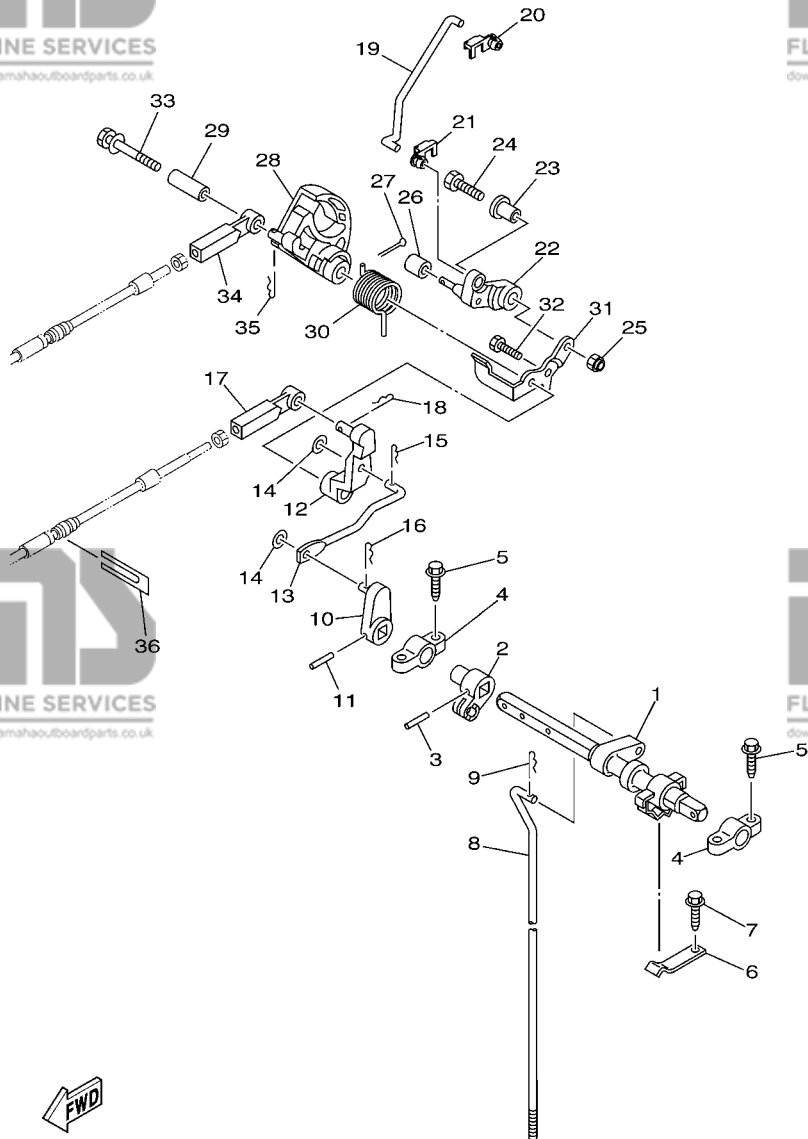


67C2300-3190

FIG. 19 CONTROL

COMMANDE

REF. NO.	PART NO. N° PIECES	DESCRIPTION DESCRIPTION	MHD	ED	ET	REMARKS REMARQUES
1	67C-44121-00	LEVER, SHIFT ROD LEVIER, TIGE D'INVERSION	1	1	1	
2	66M-44122-00	BUSHING, SHIFT ROD LEVER DOUILLE, LEVIER D'EMBRAYAGE	1	1	1	
3	90254-03M05	PIN, SPRING RIVET, TETE TRONCONIQUE	1	1	1	
4	6F5-41662-00	BRACKET SUPPORT	2	2	2	
5	90109-06M81	BOLT BOULON	4	4	4	
6	67C-44116-00	SPRING RESSORT	1	1	1	
7	90109-06M86	BOLT BOULON	1	1	1	
8	67C-44143-00	ROD, SHIFT TIGE D'EMBRAYAGE	1	1	1	S S L L
	67C-44143-10	ROD, SHIFT TIGE D'EMBRAYAGE	1	1	1	
9	90468-18008	CLIP JONC	1	1	1	
10	65W-44142-00	JOINT AXE	1	1	1	
11	90254-03M05	PIN, SPRING RIVET, TETE TRONCONIQUE	1	1	1	
12	67C-44125-00	LEVER, SHIFT ROD LEVIER, TIGE D'INVERSION	1	1	1	
13	67C-44192-00	LINK, SHIFT ROD BIELLETTTE	1	1	1	
14	90201-05M06	WASHER, PLATE RONDELLE, PLATE	2	2	2	
15	90468-10005	CLIP JONC	1	1	1	
16	90468-18008	CLIP JONC	1	1	1	
17	67C-48344-00	CABLE END, REMOTE CONTROL CHAPE CABLE	1	1	1	
18	90468-18008	CLIP JONC	1	1	1	
19	67C-41241-00	ROD, LINK BIELLETTTE	1	1	1	
20	6E9-41237-00	JOINT, LINK RACCORD	1	1	1	
21	6F5-41237-00	JOINT, LINK RACCORD	1	1	1	
22	67C-41212-00	ARM, ACCEL. BRAS	1	1	1	
23	90387-06M29	COLLAR COLLERETTE	1	1	1	
24	97095-06025	BOLT BOULON	1	1	1	
25	95780-06300	NUT, FLANGE ECROU	1	1	1	
26	62Y-42171-00	BUSHING COUSSINET	1	1	1	



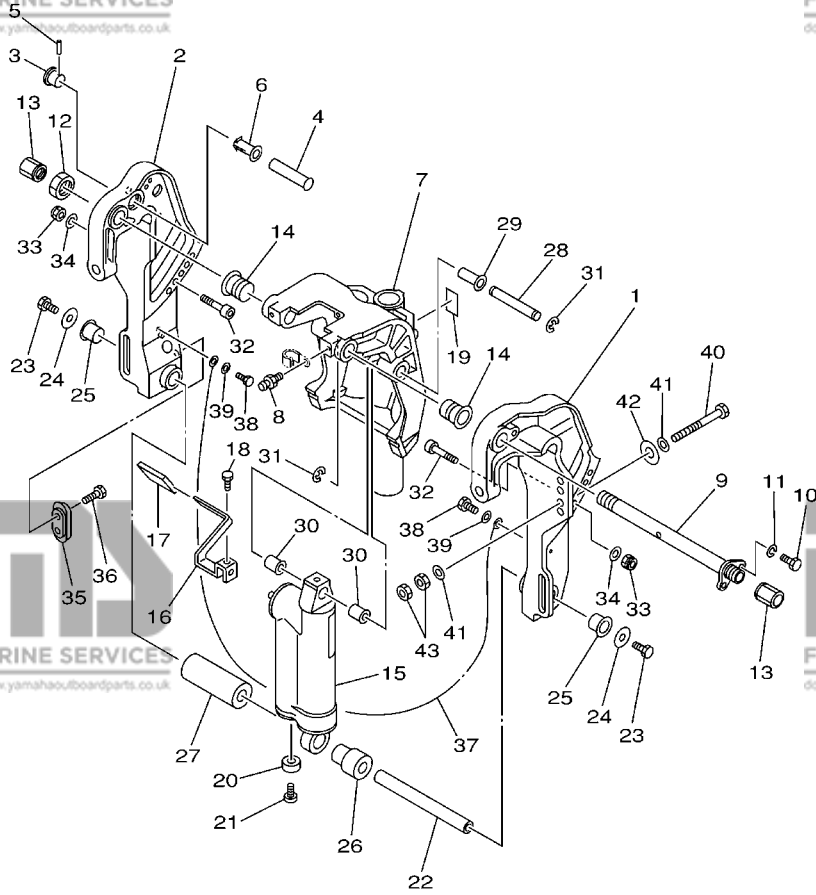
67C2300-3190

**FIG. 19 CONTROL**

**COMMANDE**

REF. NO.	PART NO. N° PIECES	DESCRIPTION DESCRIPTION	MFD	ED	ET	REMARKS REMARQUES
27	91490-12010	PIN, COTTER GOUILLE	1	1	1	
28	67C-41213-20	CAM, ACCEL. CAME, ACCELERATION	1	1	1	
29	90387-06M88	COLLAR COLLERETTE	1	1	1	
30	90508-20M44	SPRING, TORSION RESSORT, TORSION	1	1	1	
31	67C-44117-00	BRACKET SUPPORT	1	1	1	
32	97095-06014	BOLT BOULON	1	1	1	
33	90119-06M91	BOLT, WITH WASHER BOULON, AVEC RONDELLE	1	1	1	
34	67C-48344-00	CABLE END, REMOTE CONTROL CHAPE CABLE	1	1	1	
35	90468-18008	CLIP JONC	1	1	1	
36	62Y-48538-00	CLAMP, CABLE 1 COLLIER	1	1	1	

**E6**



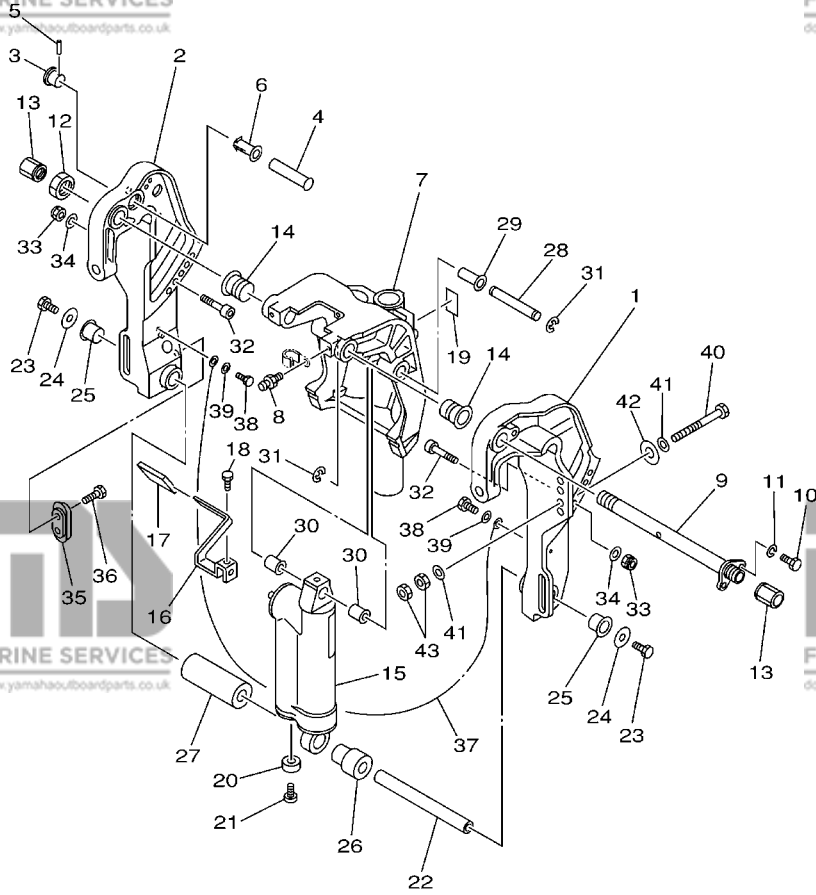
**FWD**  
67C0010-1221

**FIG. 20 BRACKET 1**

**SUPPORT 1**

REF. NO.	PART NO. N° PIECES	DESCRIPTION DESCRIPTION	MHD	ED	ET	REMARKS REMARQUES
1	67C-43111-10-4D	BRACKET, CLAMP PRESSE	1	1		
2	67C-43112-10-4D	BRACKET, CLAMP PRESSE	1	1		
3	65W-43192-00	KNOB, STOPPER BOUTON, BUTEE DE RELEVAGE	1	1		
4	65W-43191-00	SHAFT, STOPPER AXE, BUTEE	1	1		
5	91690-30018	PIN, SPRING AGRAFFE	1	1		
6	90386-14MA1	BUSH DOUILLE	1	1		
7	67C-43311-00-4D	BRACKET, SWIVEL 1 SUPPORT, PIVOT 1	1	1		S S L L
	67C-43311-10-4D	BRACKET, SWIVEL 1 SUPPORT, PIVOT 1	1	1		
8	93700-06M03	NIPPLE, GREASE PION	3	3		
9	6K9-43131-01	BOLT, CLAMP BRACKET BOULON, PRESSE	1	1		
10	97095-08020	BOLT BOULON	1	1		
11	92995-08100	WASHER RONDELLE	1	1		
12	90185-22M11	NUT, SELF-LOCKING ECROU, AUTO-BLOCANT	1	1		
13	6G5-43145-01	CAP, CLAMP BRACKET CAPUCHON, PRESSE	2	2		
14	90386-22MA4	BUSH DOUILLE	2	2		
15	67C-43170-00-4D	SHOCK ABSORBER ASSY AMORTISSEUR (ENS.)	1	1		S S L L
	67C-43170-10-4D	SHOCK ABSORBER ASSY AMORTISSEUR (ENS.)	1	1		
16	67C-43631-00	LEVER, TILT LEVIER, INCLINAISON	1	1		
17	682-43318-01	COVER CAPUCHON	1	1		
18	97095-06010	BOLT BOULON	1	1		
19	63D-43691-00	INDICATOR, TILT ETIQUETTE, RELEVAGE	1	1		
20	663-45251-00	ANODE ANODE	1	1		
21	98680-06525	SCREW, OVAL HEAD VIS, TETE FRAISEE BOMBEE	1	1		
22	90249-18M35	PIN GOUPILLE	1	1		
23	97080-08016	BOLT BOULON	2	2		
24	90201-08M00	WASHER, PLATE RONDELLE, PLATE	2	2		
25	90386-18M44	BUSH DOUILLE	2	2		

**E7**



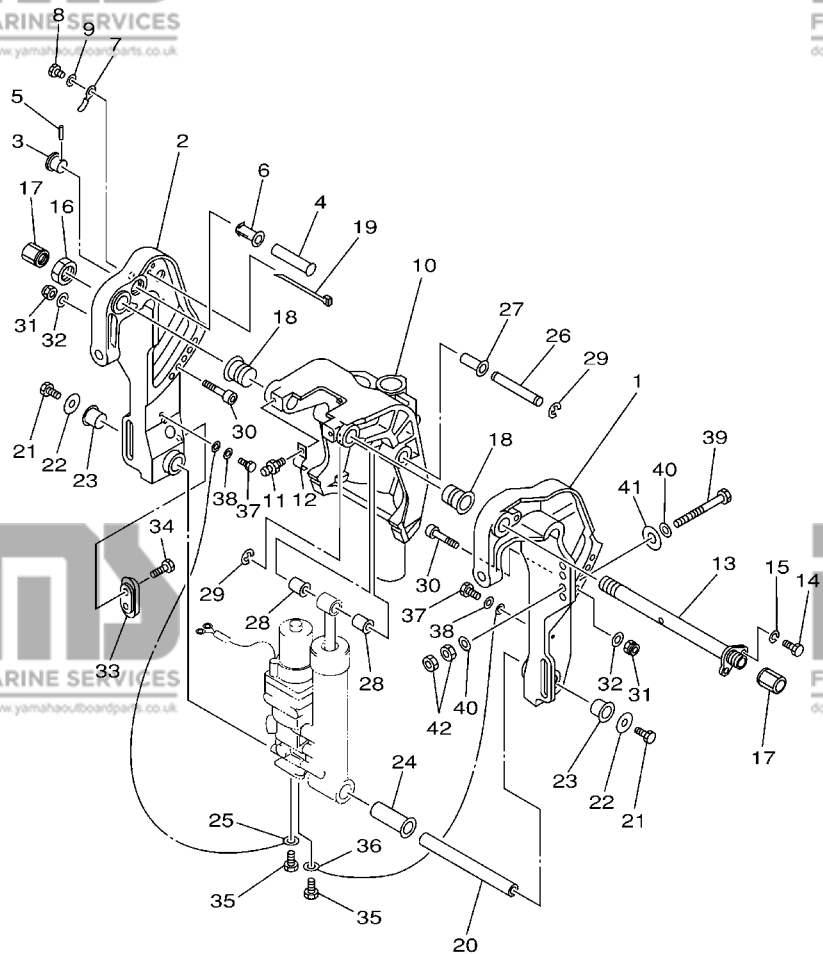
67C0010-1221

**FIG. 20 BRACKET 1**

**SUPPORT 1**

REF. NO.	PART NO. N° PIECES	DESCRIPTION DESCRIPTION	MHD	ED	ET	REMARKS REMARQUES
26	90386-18MA5	BUSH DOUILLE	1	1		
27	90387-18M03	COLLAR COLLERETTE	1	1		
28	90249-12M38	PIN GOUILLE	1	1		
29	90381-12M10	BUSH, SOLID DOUILLE, SOLIDE	1	1		
30	90381-12M11	BUSH, SOLID DOUILLE, SOLIDE	2	2		
31	93430-10M00	CIRCLIP CLIPS	2	2		
32	90110-10M02	BOLT, HEXAGON SOCKET HEAD BOULON, TETE HEXAGONALE CREUSE	2	2		
33	90185-10M13	NUT, SELF-LOCKING ECROU, AUTO-BLOCANT	2	2		
34	92995-10600	WASHER RONDELLE	2	2		
35	65W-45251-00	ANODE ANODE	1	1		
36	90101-06020	BOLT BOULON	2	2		
37	67C-82127-20	WIRE, LEAD 2 FIL 2	1	1		
38	97095-06014	BOLT BOULON	2	2		
39	92995-06600	WASHER RONDELLE	2	2		
40	90101-12M65	BOLT BOULON	4	4		
41	92995-12200	WASHER RONDELLE	8	8		
42	90201-12426	WASHER, PLATE RONDELLE, PLATE	4	4		
43	95380-12600	NUT ECROU	8	8		

**F1**



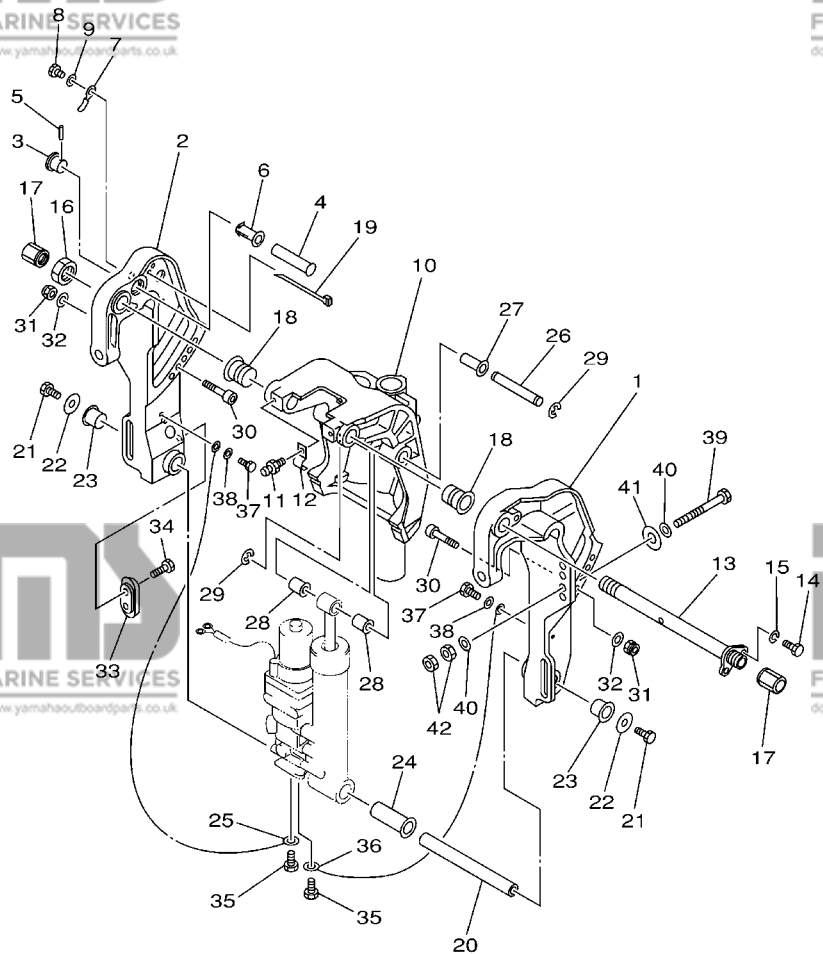
67C0010-1231

**FIG. 21 BRACKET 2**

**SUPPORT 2**

REF. NO.	PART NO. N° PIECES	DESCRIPTION DESCRIPTION	MHD	ED	ET	REMARKS REMARQUES
1	67C-43111-10-4D	BRACKET, CLAMP PRESSE			1	
2	67C-43112-10-4D	BRACKET, CLAMP PRESSE			1	
3	65W-43192-00	KNOB, STOPPER BOUTON, BUTEE DE RELEVAGE			1	
4	65W-43191-00	SHAFT, STOPPER AXE, BUTEE			1	
5	91690-30018	PIN, SPRING AGRAFFE			1	
6	90386-14MA1	BUSH DOUILLE			1	
7	90465-10M77	CLAMP BRIDE			1	
8	97095-06014	BOLT BOULON			1	
9	92995-06600	WASHER RONDELLE			1	
10	67C-43311-00-4D	BRACKET, SWIVEL 1 SUPPORT, PIVOT 1			1	S S L L
	67C-43311-10-4D	BRACKET, SWIVEL 1 SUPPORT, PIVOT 1			1	
11	93700-06M03	NIPPLE, GREASE PION			3	
12	90465-08M63	CLAMP BRIDE			1	
13	6K9-43131-01	BOLT, CLAMP BRACKET BOULON, PRESSE			1	
14	97095-08020	BOLT BOULON			1	
15	92995-08100	WASHER RONDELLE			1	
16	90185-22M11	NUT, SELF-LOCKING ECROU, AUTO-BLOCANT			1	
17	6G5-43145-01	CAP, CLAMP BRACKET CAPUCHON, PRESSE			2	
18	90386-22MA4	BUSH DOUILLE			2	
19	90465-13M11	CLAMP BRIDE			2	
20	90249-18M35	PIN GOUPILLE			1	
21	97080-08016	BOLT BOULON			2	
22	90201-08M00	WASHER, PLATE RONDELLE, PLATE			2	
23	90386-18M44	BUSH DOUILLE			2	
24	90386-18MA0	BUSH DOUILLE			1	
25	6H1-82148-00	WIRE, LEAD 4 FIL 4			1	
26	90249-12M38	PIN GOUPILLE			1	

**F2**



67C0010-1231

**FIG. 21 BRACKET 2**

**SUPPORT 2**

REF. NO.	PART NO. N° PIECES	DESCRIPTION DESCRIPTION	MFD	ED	ET	REMARKS REMARQUES
27	90381-12M10	BUSH, SOLID DOUILLE, SOLIDE			1	
28	90381-12M11	BUSH, SOLID DOUILLE, SOLIDE			2	
29	93430-10M00	CIRCLIP CLIPS			2	
30	90110-10M02	BOLT, HEXAGON SOCKET HEAD BOULON, TETE HEXAGONALE CREUSE			2	
31	90185-10M13	NUT, SELF-LOCKING ECROU, AUTO-BLOCANT			2	
32	92995-10600	WASHER RONDELLE			2	
33	65W-45251-00	ANODE ANODE			1	
34	90101-06020	BOLT BOULON			2	
35	97085-06010	BOLT BOULON			2	
36	6U0-82127-00	WIRE, LEAD 2 FIL 2			1	
37	97095-06014	BOLT BOULON			2	
38	92995-06600	WASHER RONDELLE			2	
39	90101-12M65	BOLT BOULON			4	
40	92995-12200	WASHER RONDELLE			8	
41	90201-12426	WASHER, PLATE RONDELLE, PLATE			4	
42	95380-12600	NUT ECROU			8	



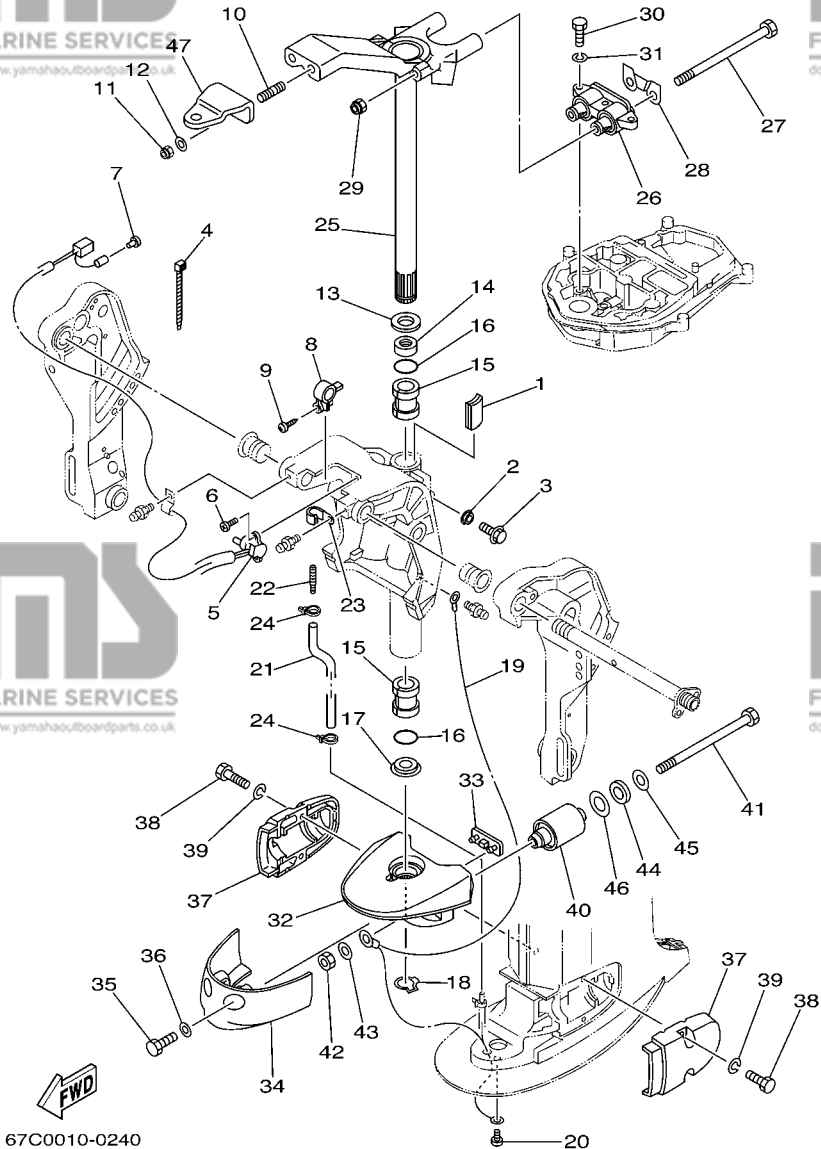


FIG. 22 BRACKET 3

SUPPORT 3

REF. NO.	PART NO. N° PIECES	DESCRIPTION DESCRIPTION	MFD	ED	ET	REMARKS REMARQUES
1	6J8-42528-00	PLATE, FRICTION PLAQUE, FRICTION	1	1	1	
2	689-43373-01	SEAL, DAMPER JOINT	1	1	1	
3	90105-06M18	BOLT, FLANGE BOULON	1	1	1	
4	90465-11M10	CLAMP BRIDE			4	
5	64E-83672-02	TRIM SENDER INCLINER RACCORD			1	
6	97885-06016	SCREW, PAN HEAD VIS, A ENCOCHE			2	
7	703-82119-00	COVER, LEAD WIRE GARNITURE, FIL			1	
8	6K9-43139-01	CAM, TRIM SENDER VILEBREQUIN TRUM			1	
9	97780-60525	SCREW, TAPPING VIS, TETE BOMBEE			1	
10	90116-10M28	BOLT, STUD GOUJON	2	2	2	
11	90185-10051	NUT, SELF-LOCKING ECROU, AUTO-BLOCANT	2	2	2	
12	92995-10600	WASHER RONDELLE	2	2	2	
13	90201-30M00	WASHER, PLATE RONDELLE, PLATE	1	1	1	
14	90386-30M78	BUSH DOUILLE	1	1	1	
15	90386-30M77	BUSH DOUILLE	2	2	2	
16	93210-29M94	O-RING JOINT TORIQUE	2	2	2	
17	90386-30M60	BUSH DOUILLE	1	1	1	
18	93410-28M06	CIRCLIP CLIPS	1	1	1	
19	67C-82127-00	WIRE, LEAD 2 FIL 2	1	1	1	S S L L
	67C-82127-10	WIRE, LEAD 2 FIL 2	1	1	1	
20	97885-06008	SCREW, PAN HEAD VIS, A ENCOCHE	1	1	1	
21	90445-07MF1	HOSE (L570) DURITE (L570)	1	1	1	S S L L
	90445-07M53	HOSE (L700) DURITE (L700)	1	1	1	
22	6E5-83558-00	END, NIPPLE RACCORD DE NIPPLE	1	1	1	
23	90465-08M07	CLAMP BRIDE	1	1	1	
24	90465-11M10	CLAMP BRIDE	2	2	2	
25	67C-42510-01-4D	STEERING BRACKET ASSY DIRECTION SUPPORT (ENS.)	1	1		S S

F4

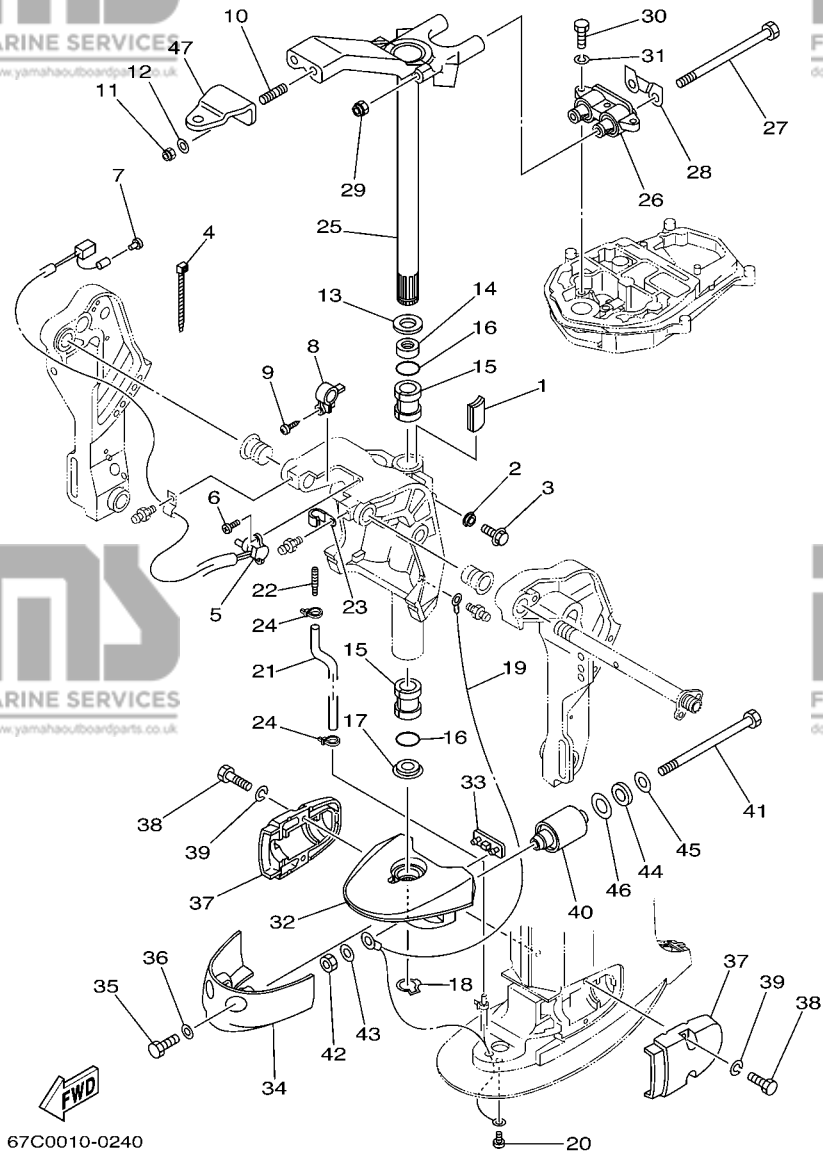
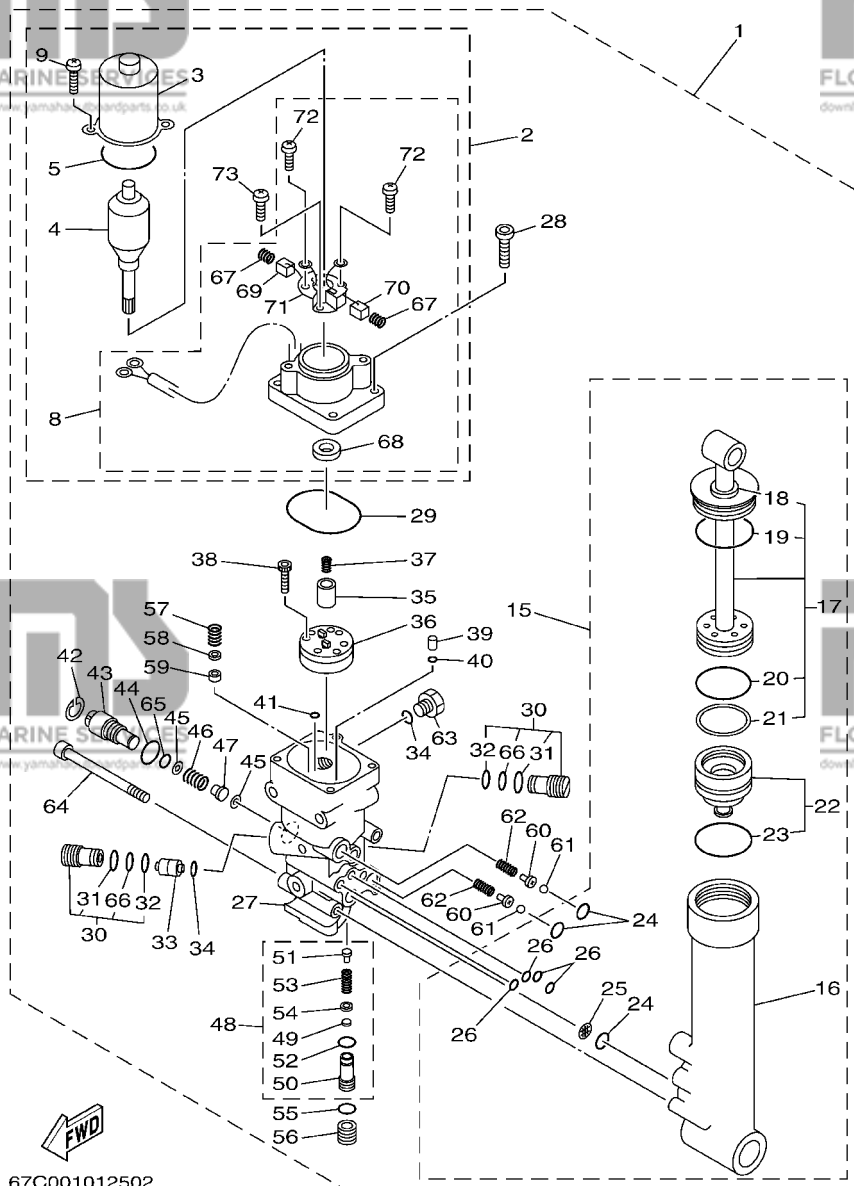


FIG. 22 BRACKET 3

SUPPORT 3

REF. NO.	PART NO. N° PIECES	DESCRIPTION DESCRIPTION	MFD	ED	ET	REMARKS REMARQUES
25	67C-42510-11-4D	STEERING BRACKET ASSY DIRECTION SUPPORT (ENS.)	1	1	1	L
26	67C-44514-00-4D	MOUNT DAMPER, UPPER SIDE SILENT-BLOC, SUPERIEUR LATERAL	1	1	1	S
	67C-44514-10-4D	MOUNT DAMPER, UPPER SIDE SILENT-BLOC, SUPERIEUR LATERAL	1	1	1	L
27	90101-08M15	BOLT BOULON	2	2	2	
28	66T-44526-30	PLATE PLAQUE	1	1	1	
29	90185-08045	NUT, SELF-LOCKING ECROU, AUTO-BLOCANT	2	2	2	
30	97075-08030	BOLT BOULON	3	3	3	
31	92995-08100	WASHER RONDELLE	3	3	3	
32	67C-44551-01-4D	HOUSING, LOWER MOUNT RUBBER BOITIER, SILENT-BLOC INFERIEUR	1	1	1	S
	67C-44551-10-4D	HOUSING, LOWER MOUNT RUBBER BOITIER, SILENT-BLOC INFERIEUR	1	1	1	L
33	67C-44575-00	DAMPER, LOWER MOUNT RUBBER SILENT-BLOC, INFERIEUR	1	1	1	
34	67C-44553-00-4D	COVER, LOWER MOUNT COUVERCLE, SUSPENSION INFERIEUR	1	1	1	
35	97095-08020	BOLT BOULON	2	2	2	
36	92995-08600	WASHER RONDELLE	2	2	2	
37	67C-44552-01-4D	HOUSING, LOWER MOUNT RUBBER BOITIER, SILENT-BLOC INFERIEUR	2	2	2	
38	97075-08030	BOLT BOULON	4	4	4	
39	92995-08100	WASHER RONDELLE	4	4	4	
40	67C-44555-21-94	MOUNT DAMPER, LOWER SIDE SILENT-BLOC, INFERIEUR LATERAL	2	2	2	S
	67C-44555-11-94	MOUNT DAMPER, LOWER SIDE SILENT-BLOC, INFERIEUR LATERAL	2	2	2	L
41	90109-12MA3	BOLT BOULON	2	2	2	
42	95380-12700	NUT ECROU	2	2	2	
43	90201-12M16	WASHER, PLATE RONDELLE, PLATE	4	4	4	
44	90202-21100	WASHER, PLATE RONDELLE, PLATE	2	2	2	
45	90201-13M19	WASHER, PLATE RONDELLE, PLATE	2	2	2	
46	90201-22M05	WASHER, PLATE RONDELLE, PLATE	2	2	2	
47	65W-48511-00	HOOK, STEERING ATTACHE, DIRECTION	1	1	1	



67C001012502

FIG. 23 POWER TRIM & TILT ASSY PUISSANCE PARER ET INCLINER

REF. NO.	PART NO. N° PIECES	DESCRIPTION DESCRIPTION	MHD	ED	ET	REMARKS REMARQUES
1	67C-43800-00-4D	POWER TRIM & TILT ASSY PUISSANCE PARER ET INCLINER (ENS.)			1	
2	67C-43880-00	..MOTOR ASSY ..MOTEUR (ENS.)			1	
3	65W-43804-00	..STATOR ASSY ..STATOR (ENS.)			1	
4	65W-43805-00	..ARMATURE ASSY ..INDUIT (ENS.)			1	
5	65W-43869-00	..O-RING ..JOINT TORIQUE			1	
8	67C-43881-00	..FRAME, END ..BATI			1	
9	65W-43887-00	..BOLT, THROUGH ..BOULON			2	
15	67C-43840-00	..POWER TILT ASSY ..PUISSANCE INCLINER (ENS.)			1	
16	65W-4380K-00	..CYLINDER, TILT SUB ASSY ..CYLINDRE			1	
17	67C-43810-00	..TILT PISTON SUB ASSY ..INCLINER PISTON AUXILIAIRE(ENS.)			1	
18	65W-43812-00	..SEAL, DUST ..JOINT			1	
19	65W-43865-00	..O-RING ..JOINT TORIQUE			1	
20	6H1-43861-10	..O-RING ..JOINT TORIQUE			1	
21	65W-43871-00	..RING, BACK UP ..SEGMENT			1	
22	65W-4381B-00	..FREE PISTON SUB ASSY ..PISTON AUXILIAIRE (ENS.)			1	
23	6H1-43861-10	..O-RING ..JOINT TORIQUE			1	
24	93210-11368	..O-RING ..JOINT TORIQUE			3	
25	6H1-43816-00	..FILTER 1 ..FILTRE 1			1	
26	93210-064A5	..O-RING ..JOINT TORIQUE			4	
27	67C-4380L-00	..HOUSING, TRIM & TILT SUB ASSY ..CARTER			1	

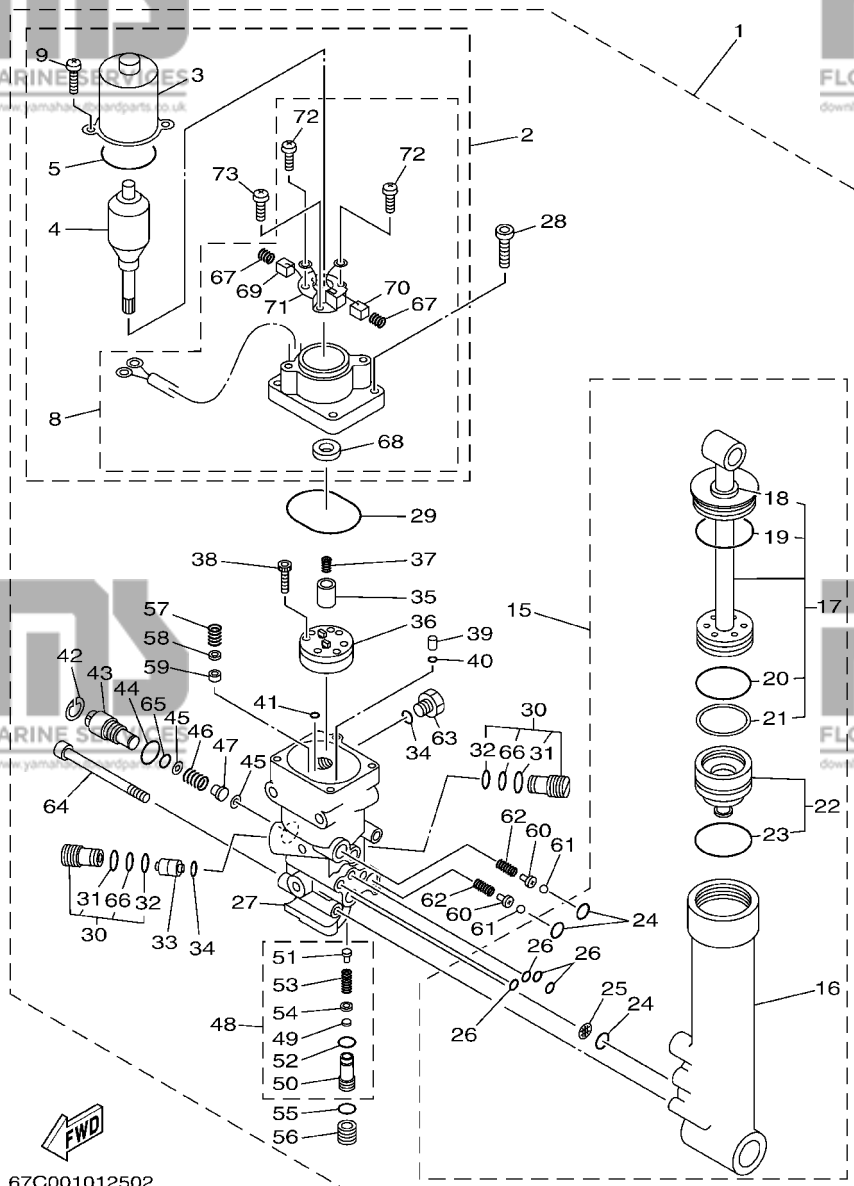
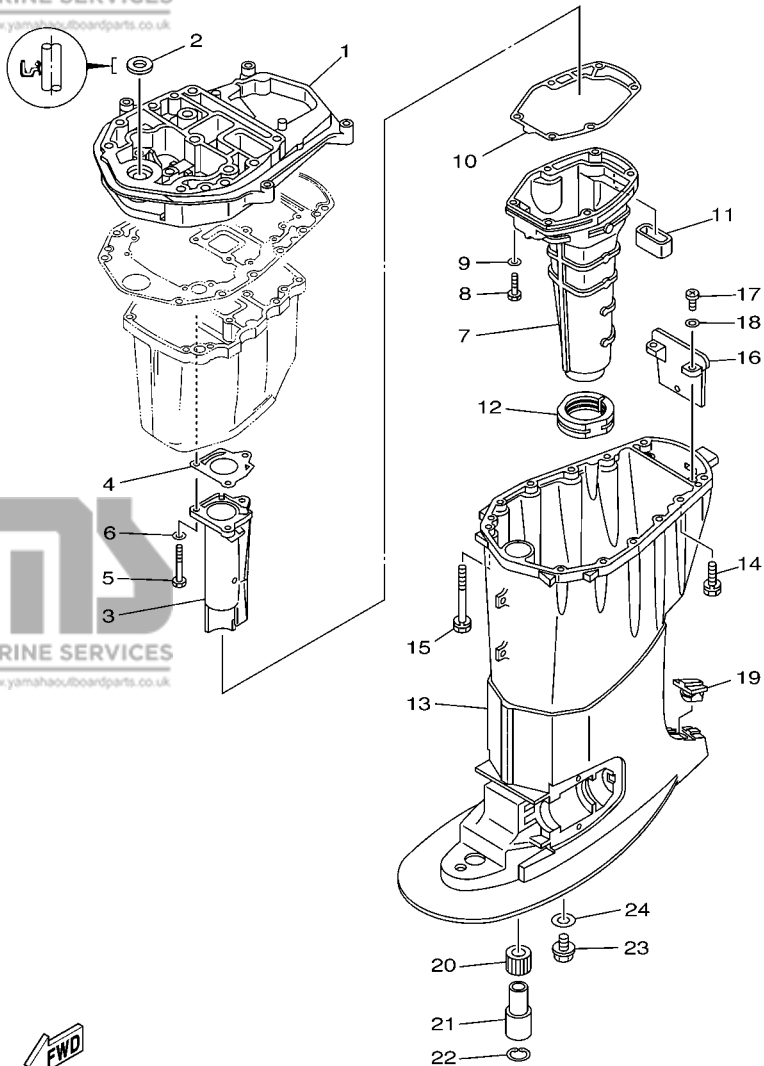


FIG. 23 POWER TRIM & TILT ASSY

PUISSANCE PARER ET INCLINER

REF. NO.	PART NO. N° PIECES	DESCRIPTION DESCRIPTION	MHD	ED	ET	REMARKS REMARQUES
28	65W-43888-00	.BOLT, SOCKET .BOULON			4	
29	93210-50768	.O-RING .JOINT TORIQUE			1	
30	6T4-43802-03	.VALVE SUB ASSY .CLAPET AUXILIAIRE (ENS.)			2	
31	6H1-43866-00	..O-RING ..JOINT TORIQUE			1	
32	6H1-43867-00	..O-RING ..JOINT TORIQUE			1	
33	62X-43841-00	.PISTON, SHUTTLE .PISTON			1	
34	93210-09165	.O-RING .JOINT TORIQUE			3	
35	65W-43831-00	.CONNECTOR, SHAFT .RACCORD			1	
36	65W-43830-00	.GEAR PUMP ASSY .POMPE A PIGNON (ENS.)			1	
37	6T4-43853-00	.SPRING, MAIN VALVE .RESSORT			1	
38	91318-04025	.BOLT .BOULON			4	
39	65W-43817-00	.FILTER 2 .FILTRE 2			2	
40	65W-43861-00	.O-RING .JOINT TORIQUE			2	
41	65W-43862-00	.O-RING .JOINT TORIQUE			2	
42	6H1-43875-00	.RING, SNAP .RESSORT			1	
43	6H1-43845-00	.SCREW, MANUAL RELEASE .VIS			1	
44	93210-18397	.O-RING .JOINT TORIQUE			1	
45	6H1-43847-00	.SEAT, MANUAL VALVE .SIEGE			2	
46	65W-43854-00	.SPRING, MANUAL RELEASE .RESSORT			1	
47	65W-4382A-00	.ADAPTOR 1 .ADAPTEUR 1			1	
48	CS2-43803-81	.CASE VALVE COMP. .CARTER VALVE COMP.			1	
49	6H1-4384G-11	..SEAL, RELIEF VALVE ..JOINT			1	
50	CS2-43851-80	..SEAT, RELIEF VALVE ..SIEGE			1	
51	67F-43843-00	..SCREW, VALVE LOCK ..VIS			1	
52	93210-10M74	..O-RING ..JOINT TORIQUE			1	
53	6H1-43856-10	..SPRING, DOWN RELIEF ..RESSORT			1	
54	6H1-43844-10	..PIN, VALVE SUPPORT ..GOUILLE			1	





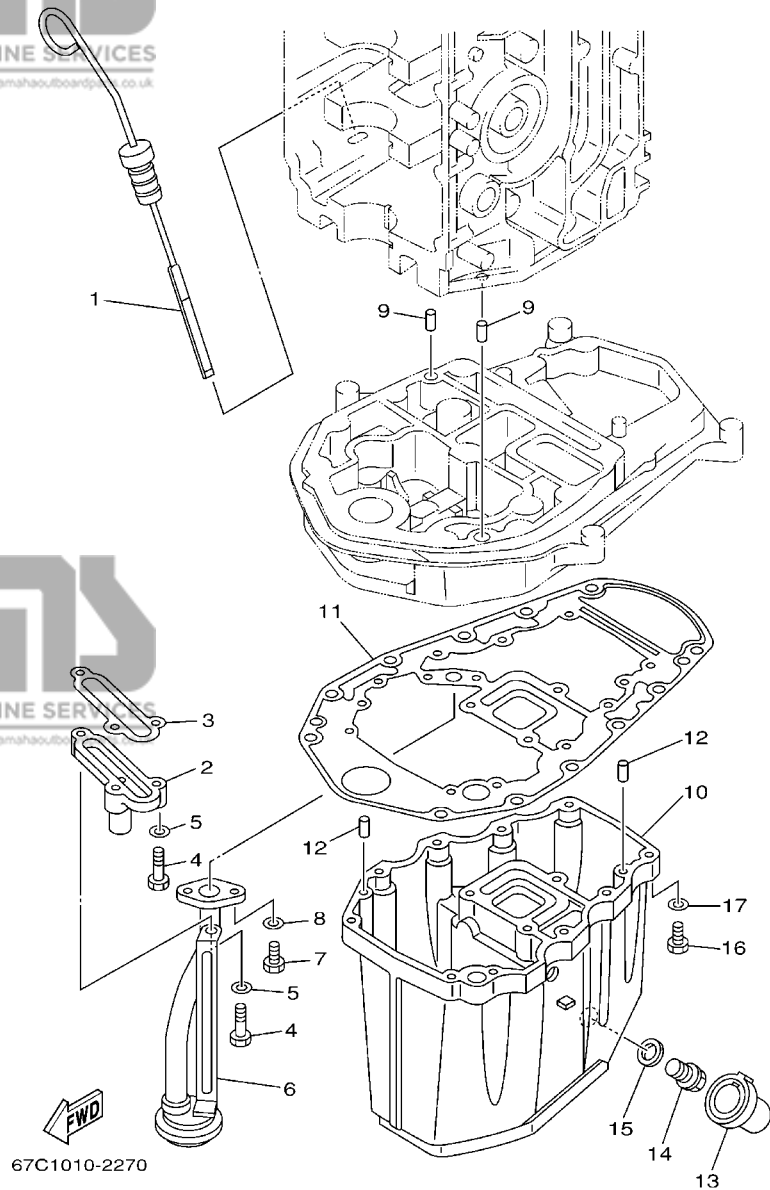
67C2100-3260

FIG. 24 UPPER CASING

FOURREAU

REF. NO.	PART NO. N° PIECES	DESCRIPTION DESCRIPTION	MHD	ED	ET	REMARKS REMARQUES
1	67C-41137-01-94	GUIDE, EXHAUST COLLECTEUR D'ÉCHAPPEMENT	1	1	1	
2	93110-16004	OIL SEAL JOINT D'HUILE	1	1	1	
3	67C-41131-00-5B	MANIFOLD, EXT. 1 PIPE D'ÉCHAPPEMENT	1	1	1	
4	67C-41133-00	GASKET, EXHAUST MANIFOLD 1 JOINT, PIPE D'ÉCHAPPEMENT	1	1	1	
5	97075-06050	BOLT BOULON	3	3	3	
6	92995-06600	WASHER RONDELLE	3	3	3	
7	67C-14711-00-5B	MUFFLER 1 POT D'ÉCHAPPEMENT 1	1	1	1	S S
	67C-14711-12-5B	MUFFLER 1 POT D'ÉCHAPPEMENT 1	1	1	1	L L
8	97075-06025	BOLT BOULON	6	6	6	
9	92995-06600	WASHER RONDELLE	6	6	6	
10	62Y-41134-01	GASKET, EXHAUST MANIFOLD JOINT, PIPE D'ÉCHAPPEMENT	1	1	1	
11	62Y-45127-00	SEAL JOINT	1	1	1	
12	67C-45123-00	GASKET, MUFFLER JOINT, POT DE DÉTENTE	1	1	1	
13	67C-45111-00-4D	CASING, UPPER FOURREAU	1	1	1	S S
	67C-45111-21-4D	CASING, UPPER FOURREAU	1	1	1	L L
14	90119-08M79	BOLT, WITH WASHER BOULON, AVEC RONDELLE	4	4	4	
15	90119-08M82	BOLT, WITH WASHER BOULON, AVEC RONDELLE	8	8	8	
16	67C-45151-00	COVER, UPPER CASING CAPUCHON, FOURREAU	1	1	1	
17	97880-05016	SCREW, PAN HEAD VIS, TÊTE TRONCONIQUE	2	2	2	
18	92990-05600	WASHER, PLATE RONDELLE, PLATE	2	2	2	
19	63D-45155-00	CAP CAPUCHON	1	1	1	S S
	6H3-45155-00	CAP CAPUCHON	1	1	1	L L
20	679-45318-00	BUSHING, DRIVE SHAFT DOUILLE, ARBRE MOTEUR	1	1	1	L L
21	90387-23002	COLLAR COLLERETTE	1	1	1	L L
22	93420-36M01	CIRCLIP CIRCLIP, TYPE S	1	1	1	L L
23	90340-14M06	PLUG, STRAIGHT SCREW PLOT, FILETE DROIT	1	1	1	L L
24	90430-14M09	GASKET JOINT	1	1	1	L L

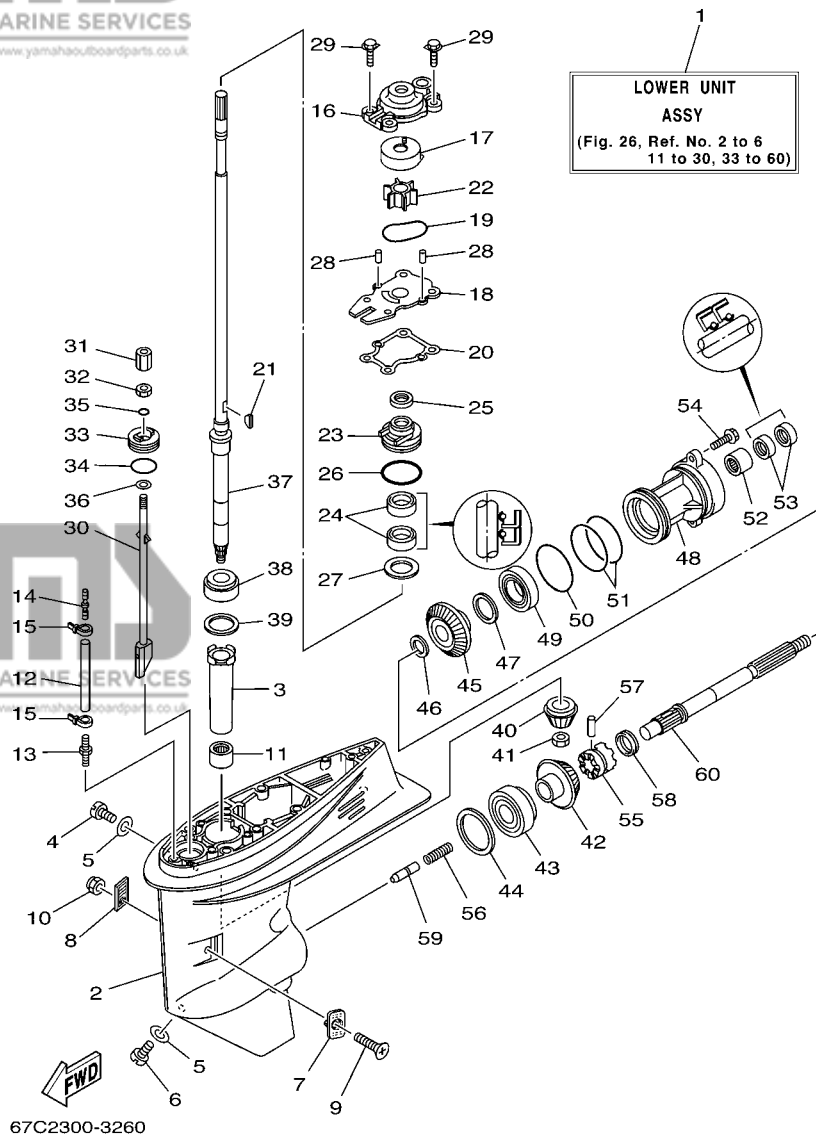
A5



**FIG. 25 OIL PAN**

**VENTILATEUR D'HUILE**

REF. NO.	PART NO. N° PIECES	DESCRIPTION DESCRIPTION	MHD	ED	ET	REMARKS REMARQUES
1	67C-15362-00	PLUG, OIL LEVEL PLOT, NIVEAU D'HUILE	1	1	1	
2	62Y-11575-00	RELIEF VALVE ASSY SOUPAPE DE RENTREE D'AIR	1	1	1	
3	62Y-13475-00	GASKET JOINT	1	1	1	
4	97013-06025	BOLT BOULON	3	3	3	
5	92903-06600	WASHER, PLATE RONDELLE, PLATE	3	3	3	
6	62Y-13411-00	STRAINER, OIL FILTRE, HUILE	1	1	1	
7	97013-06016	BOLT BOULON	2	2	2	
8	92903-06600	WASHER, PLATE RONDELLE, PLATE	2	2	2	
9	93608-12M05	PIN, DOWEL AXE	2	2	2	
10	62Y-15311-02-5B	OIL PAN VENTILATEUR D'HUILE	1	1	1	
11	69W-15312-00	GASKET, OIL PAN JOINT DE VENTILATEUR D'HUILE	1	1	1	
12	93606-12019	PIN, DOWEL GÓUPILLE	4	4	4	
13	67C-15316-10 67C-15316-00	DAMPER, ENGINE MOUNT 1 AMORTISSEUR DE SUPPORT DAMPER, ENGINE MOUNT 1 AMORTISSEUR DE SUPPORT	1 1	1 1	1 1	S S L L
14	90340-14M06	PLUG, STRAIGHT SCREW PLOT, FILETE DROIT	1	1	1	
15	90430-14M09	GASKET JOINT	1	1	1	
16	97075-06025	BOLT BOULON	10	10	10	
17	92995-06600	WASHER RONDELLE	10	10	10	



**LOWER UNIT ASSY**  
(Fig. 26, Ref. No. 2 to 6  
11 to 30, 33 to 60)

**FIG. 26 LOWER CASING & DRIVE 1**

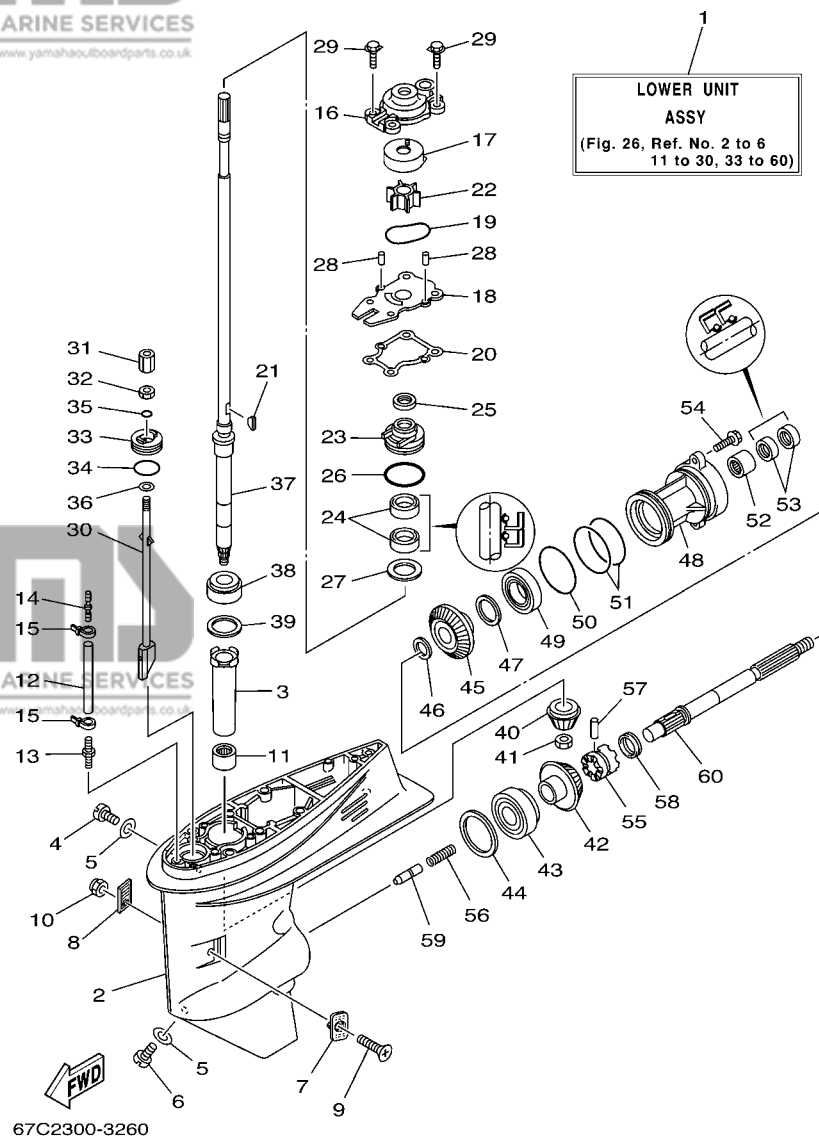
**BOITIER D'HELICE TRANSMISSION 1**

REF. NO.	PART NO. N° PIECES	DESCRIPTION DESCRIPTION	MHD	ED	ET	REMARKS REMARQUES
1	67C-45300-01-4D	LOWER UNIT ASSY UNITE INFERIEURE (ENS.)	1		1	S S L L
	67C-45300-11-4D	LOWER UNIT ASSY UNITE INFERIEURE (ENS.)	1	1	1	
2	67C-45301-00-4D	CASING, LOWER BEQUILLE	1	1	1	
3	6H4-45536-00	SLEEVE, DRIVE SHAFT MANCHON, ARBRE MOTEUR	1	1	1	
4	90340-08002	PLUG, STRAIGHT SCREW PLOT, FILETE DROIT	1	1	1	
5	90430-08020	GASKET JOINT	2	2	2	
6	688-45341-10	PLUG, DRAIN BOUCHON DE VIDANGE	1	1	1	
7	63D-45214-00	COVER, WATER INLET GRILLE, ENTREE D'EAU	1	1	1	
8	63D-45215-00	COVER, WATER INLET GRILLE, ENTREE D'EAU	1	1	1	
9	90142-05M06	SCREW, COUNTERSUNK VIS, TETE NOYEE	1	1	1	
10	95380-05600	NUT ECROU	1	1	1	
11	93315-32224	BEARING ROULEMENT	1	1	1	
12	90445-07ME8	HOSE (L80) DURITE (L80)	1	1	1	
13	6E5-45378-00	NIPPLE, HOSE RACCORD, TUYAU	1	1	1	
14	6E5-83558-10	END, NIPPLE RACCORD DE NIPPLE	1	1	1	
15	90465-11M10	CLAMP BRIDE	2	2	2	
16	66T-44311-00	HOUSING, WATER PUMP CORPS, POMPE A EAU	1	1	1	
17	63D-44322-00	INSERT, CARTRIDGE CUVETTE	1	1	1	
18	66T-44323-00	OUTER PLATE, CARTRIDGE PLAQUE EXTERIEURE	1	1	1	
19	93210-59MG7	O-RING JOINT TORIQUE	1	1	1	
20	63D-44316-00	GASKET, WATER PUMP JOINT, POMPE A EAU	1	1	1	
21	90280-03M03	KEY, WOODRUFF CLAVETTE, DEMI-LUNE	1	1	1	
22	6H4-44352-02	IMPELLER TURBINE	1	1	1	
23	63D-44341-00	HOUSING, WATER PUMP CORPS, POMPE A EAU	1	1	1	
24	93101-22M60	OIL SEAL JOINT SPY	2	2	2	
25	66T-45344-01	COVER, OIL SEAL FLASQE, JOINT D'HUILE	1	1	1	
26	93210-48MG8	O-RING JOINT TORIQUE	1	1	1	



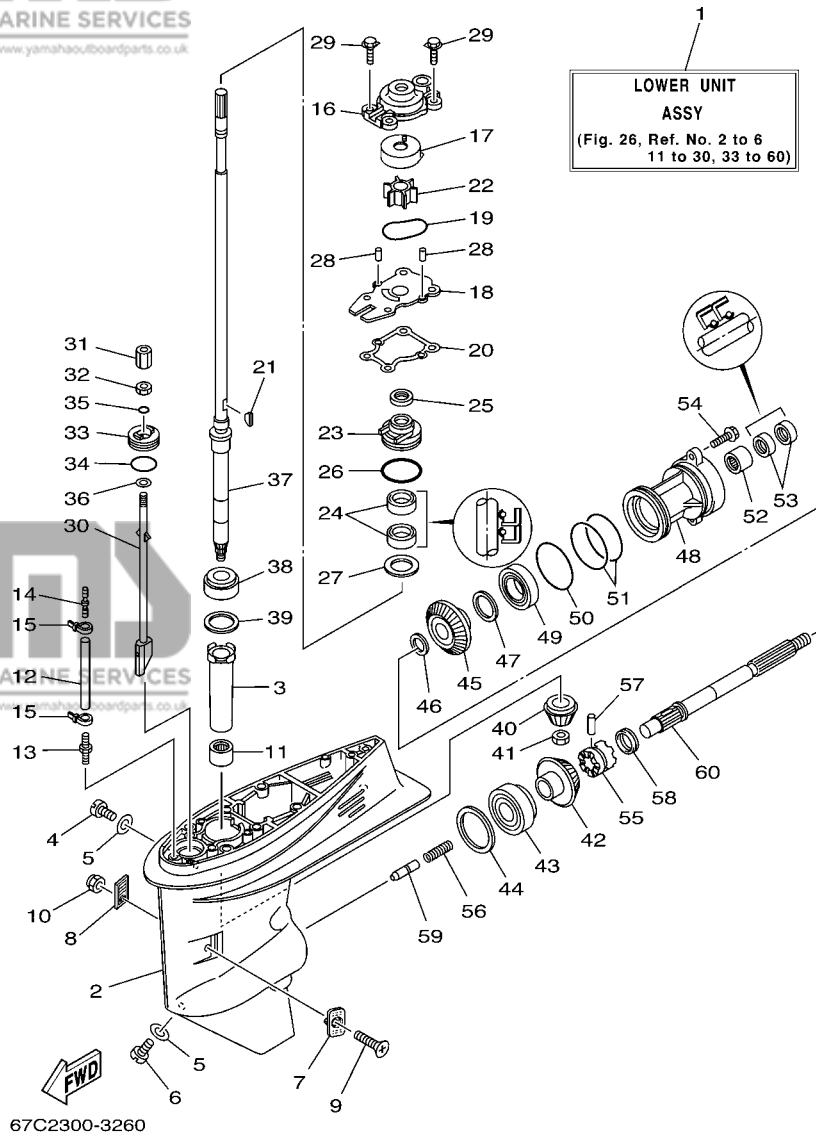
**FIG. 26 LOWER CASING & DRIVE 1**

**BOITIER D'HELICE TRANSMISSION 1**



REF. NO.	PART NO. N° PIECES	DESCRIPTION DESCRIPTION	MHD	ED	ET	REMARKS REMARQUES
27	90201-27M00	WASHER, PLATE RONDELLE, PLATE	1	1	1	
28	93604-08062	PIN, DOWEL CLAVETTE	2	2	2	
29	90119-08M15	BOLT, WITH WASHER BOULON, AVEC RONDELLE	4	4	4	
30	67C-44150-10	SHIFT CAM ASSY CAME D'INVERSION	1	1	1	
31	67C-44146-00	CONNECTOR, SHIFT ROD CONNECTEUR, TIGE D'INVERSION	1	1	1	
32	95380-06700	NUT ECROU	1	1	1	
33	66T-45321-00	PLATE PLAQUETTE	1	1	1	
34	93210-33MG4	O-RING JOINT TORIQUE	1	1	1	
35	93210-06ME6	O-RING JOINT TORIQUE	1	1	1	
36	92990-06600	WASHER, PLATE RONDELLE, PLATE	1	1	1	
37	67C-45501-00	DRIVE SHAFT COMP. ARBRE MOTEUR COMP.	1		1	S S
	67C-45501-10	DRIVE SHAFT COMP. ARBRE MOTEUR COMP.	1	1	1	L L
38	93332-00001	BEARING ROULEMENT	1	1	1	
39	663-45587-01-10	SHIM (T:0.10MM) CALE (T:0.10MM)	1	1	1	UR
	663-45587-01-12	SHIM (T:0.12MM) CALE (T:0.12MM)	1	1	1	UR
	663-45587-01-15	SHIM (T:0.15MM) CALE (T:0.15MM)	1	1	1	UR
	663-45587-01-18	SHIM (T:0.18MM) CALE (T:0.18MM)	1	1	1	UR
	663-45587-01-30	SHIM (T:0.30MM) CALE (T:0.30MM)	1	1	1	UR
	663-45587-01-40	SHIM (T:0.40MM) CALE (T:0.40MM)	1	1	1	UR
	663-45587-01-50	SHIM (T:0.50MM) CALE (T:0.50MM)	1	1	1	UR
40	66T-45551-00	PINION PIGNON D'ATTAQUE	1	1	1	
41	90170-12138	NUT ECROU	1	1	1	
42	66T-45560-01	GEAR PIGNON	1	1	1	
43	93332-00003	BEARING ROULEMENT	1	1	1	
44	663-45567-01-10	SHIM (T:0.10MM) CALE (T:0.10MM)	1	1	1	UR
	663-45567-01-12	SHIM (T:0.12MM) CALE (T:0.12MM)	1	1	1	UR
	663-45567-01-15	SHIM (T:0.15MM) CALE (T:0.15MM)	1	1	1	UR

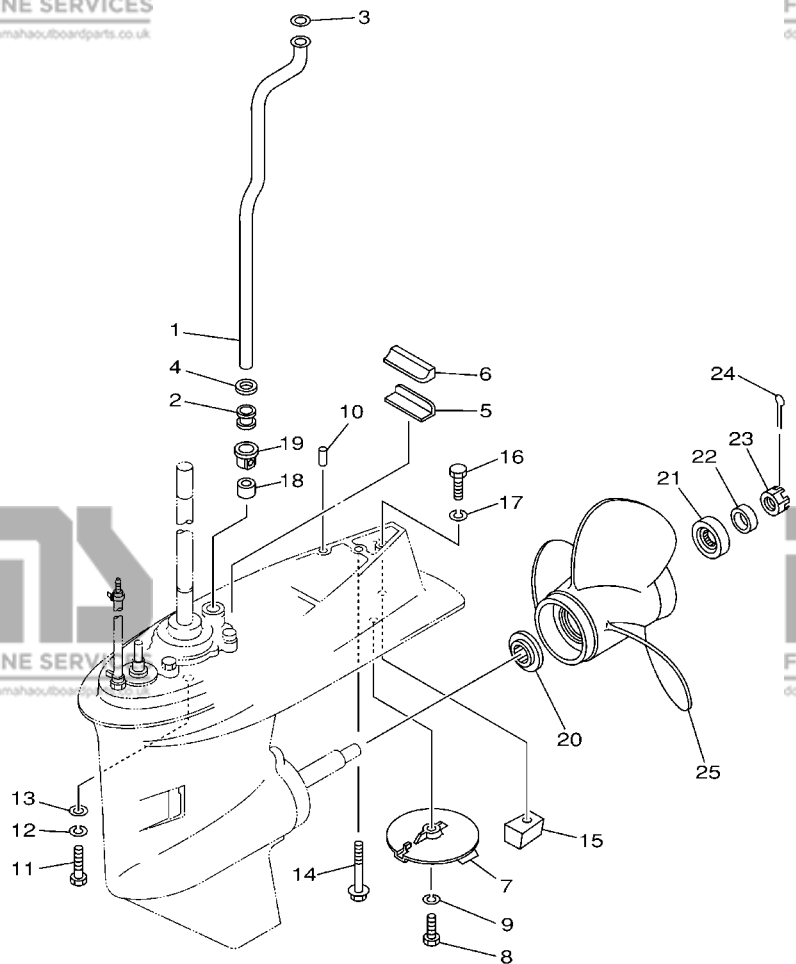
**B1**



**FIG. 26 LOWER CASING & DRIVE 1**

**BOITIER D'HELICE TRANSMISSION 1**

REF. NO.	PART NO. N° PIECES	DESCRIPTION DESCRIPTION	MHD	ED	ET	REMARKS REMARQUES
44	663-45567-01-18	SHIM (T:0.18MM)	1	1	1	UR
		CALE (T:0.18MM)				UR
	663-45567-01-30	SHIM (T:0.30MM)	1	1	1	UR
		CALE (T:0.30MM)				UR
	663-45567-01-40	SHIM (T:0.40MM)	1	1	1	UR
		CALE (T:0.40MM)				UR
	663-45567-01-50	SHIM (T:0.50MM)	1	1	1	UR
		CALE (T:0.50MM)				UR
45	66T-45571-00	GEAR PIGNON	1	1	1	
46	90201-22429	WASHER, PLATE RONDELLE, PLATE	1	1	1	
47	63D-45577-00-10	SHIM (T:0.10MM)	1	1	1	UR
		CALE (T:0.10MM)				UR
	63D-45577-00-12	SHIM (T:0.12MM)	1	1	1	UR
		CALE (T:0.12MM)				UR
	63D-45577-00-15	SHIM (T:0.15MM)	1	1	1	UR
		CALE (T:0.15MM)				UR
	63D-45577-00-18	SHIM (T:0.18MM)	1	1	1	UR
		CALE (T:0.18MM)				UR
	63D-45577-00-30	SHIM (T:0.30MM)	1	1	1	UR
		CALE (T:0.30MM)				UR
	63D-45577-00-40	SHIM (T:0.40MM)	1	1	1	UR
		CALE (T:0.40MM)				UR
	63D-45577-00-50	SHIM (T:0.50MM)	1	1	1	UR
		CALE (T:0.50MM)				UR
48	63D-45361-02-4D	CAP, LOWER CASING COUVERCLE, BOITIER D'HELICE	1	1	1	
49	93306-001U1	BEARING ROULEMENT	1	1	1	
50	93210-69MG6	O-RING JOINT TORIQUE	1	1	1	
51	93210-74MG5	O-RING JOINT TORIQUE	2	2	2	
52	93317-22204	BEARING ROULEMENT	1	1	1	
53	93101-22M00	OIL SEAL JOINT SPY	2	2	2	
54	90105-08M61	BOLT, FLANGE BOULON	2	2	2	
55	66T-45631-00	CLUTCH, DOG CRABOT	1	1	1	
56	90501-18M01	SPRING, COMPRESSION RESSORT, COMPRESSION	1	1	1	
57	90250-06023	PIN, STRAIGHT GOUPILLE, DROITE	1	1	1	
58	67C-45633-00	RING, CROSS PIN JONC, GOUPILLE CRABOT	1	1	1	
59	66T-45635-00	PLUNGER, SHIFT POUSSOIR D'EMBRAYAGE	1	1	1	
60	66T-45611-00	SHAFT, PROPPELLER ARBRE, HELICE	1	1	1	



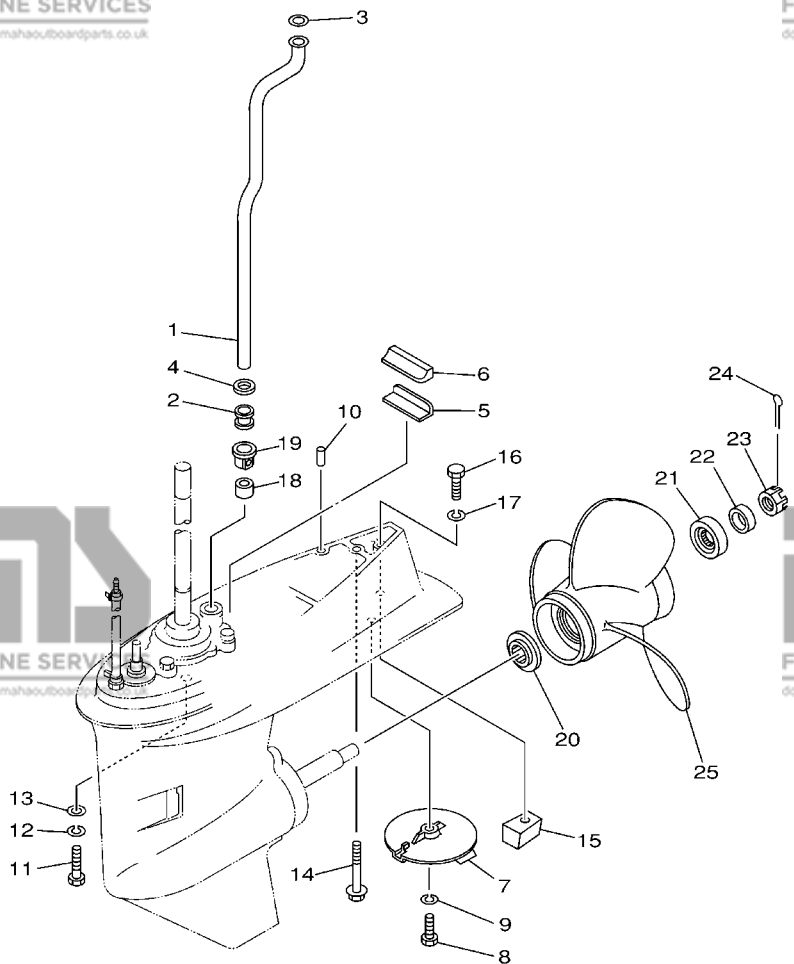
67C0010-0290

**FIG. 27 LOWER CASING & DRIVE 2**

**BOITIER D'HELICE TRANSMISSION 2**

REF. NO.	PART NO. N° PIECES	DESCRIPTION DESCRIPTION	MHD	ED	ET	REMARKS REMARQUES
1	67C-44361-00	TUBE, WATER TUBE D'EAU	1		1	S L L
	62Y-44361-00	TUBE, WATER TUBE D'EAU	1	1	1	
2	663-44367-00	DAMPER, WATER SEAL JOINT TUBE D'EAU	1	1	1	
3	90202-12060	WASHER, PLATE RONDELLE, PLATE	1	1	1	
4	90430-12072	GASKET JOINT	1	1	1	
5	663-45376-00-94	GUIDE, SEAL DAMPER BUTEE, JOINT CAOUTCHOUC	1	1	1	
6	63D-45375-00	DAMPER, SEAL BOURRELET, CAOUTCHOUC	1	1	1	
7	67C-45371-00	TAB-TRIM ANODE DERIVE	1	1	1	
8	97095-08025	BOLT BOULON	1	1	1	
9	92995-08100	WASHER RONDELLE	1	1	1	
10	93606-12019	PIN, DOWEL GOUPILLE	2	2	2	
11	97075-10040	BOLT BOULON	4	4	4	
12	92995-10100	WASHER RONDELLE	4	4	4	
13	92995-10600	WASHER RONDELLE	4	4	4	
14	90119-08M44	BOLT, WITH WASHER BOULON, AVEC RONDELLE	1	1	1	
15	67C-45251-00	ANODE ANODE	1	1	1	
16	97095-08035	BOLT BOULON	1	1	1	
17	92995-08100	WASHER RONDELLE	1	1	1	
18	663-44366-00	DAMPER, WATER SEAL JOINT, TUBE D'EAU	1	1	1	
19	63D-44312-00	COVER, WATER PUMP HOUSING COUVERCLE	1	1	1	
20	663-45987-02	SPACER ENTRETOISE	1	1	1	
21	66T-45997-00	SPACER ENTRETOISE	1	1	1	
22	90389-22M01	BUSH DOUILLE	1	1	1	
23	90171-16011	NUT, CASTLE ECROU, CRENELE	1	1	1	
24	91490-30025	PIN, COTTER GOUPILLE	1	1	1	
25	69W-45945-00-EL	PROPELLER (3X11-1/8"X13"-G) HELICE (3X11-1/8"X13"-G)	1	1	1	UR UR UR UR
	69W-45947-00-EL	PROPELLER (3X11-5/8"X11"-G) HELICE (3X11-5/8"X11"-G)	1	1	1	

**B3**



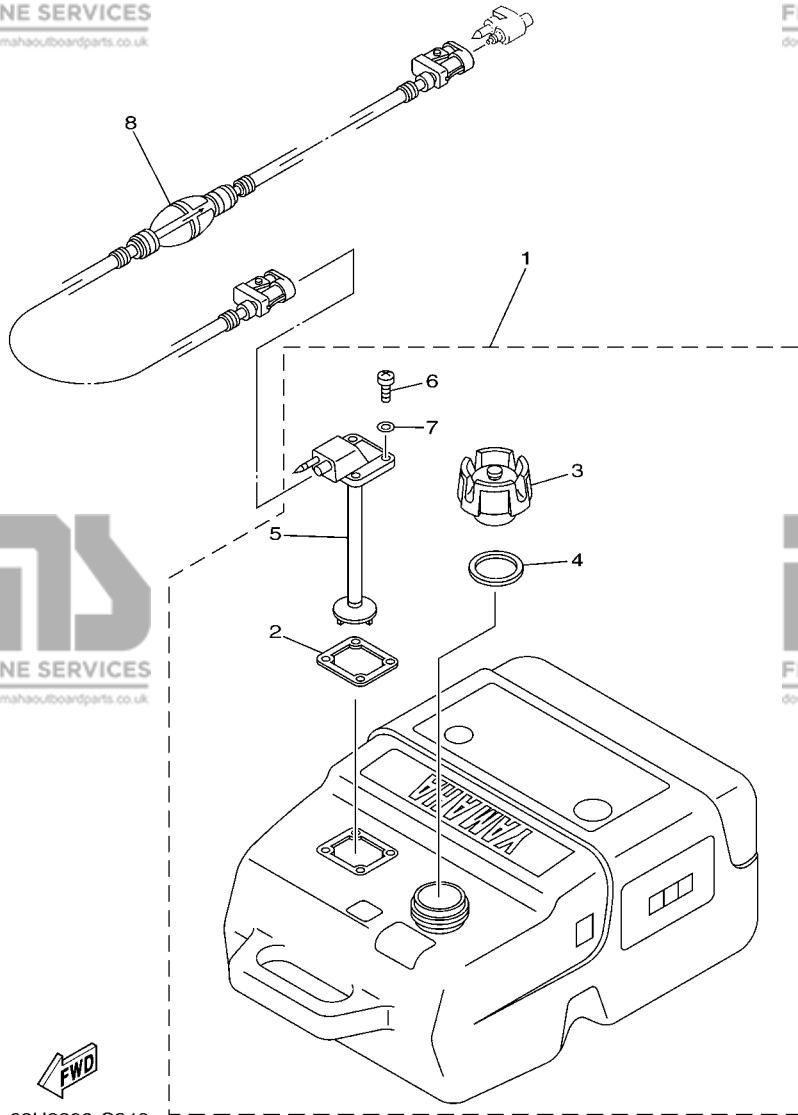
67C0010-0290

**FIG. 27 LOWER CASING & DRIVE 2**

**BOITIER D'HELICE TRANSMISSION 2**

REF. NO.	PART NO. N° PIECES	DESCRIPTION DESCRIPTION	MHD	ED	ET	REMARKS REMARQUES
25	69W-45952-00-EL	PROPELLER (3X11-3/8"X12"-G) HELICE (3X11-3/8"X12"-G)	1	1	1	UR UR
	663-45941-01-EL	PROPELLER (3X10-3/4"X17"-G) HELICE (3X10-3/4"X17"-G)	1	1	1	UR UR
	663-45949-01-EL	PROPELLER (3X10-3/4"X16"-G) HELICE (3X10-3/4"X16"-G)	1	1	1	UR UR
	663-45952-02-EL	PROPELLER (3X11-3/8"X12"-G) HELICE (3X11-3/8"X12"-G)	1	1	1	UR UR
	663-45956-01-EL	PROPELLER (3X12-1/4"X9"-G) HELICE (3X12-1/4"X9"-G)	1	1	1	UR UR
	663-45958-01-EL	PROPELLER (3X11-1/4"X14"-G) HELICE (3X11-1/4"X14"-G)	1	1	1	UR UR
	6H5-45943-00-EL	PROPELLER (3X10"X15"-G) HELICE (3X10"X15"-G)	1	1	1	UR WITH LIP CUP UR WITH LIP CUP
	6H5-45945-00-EL	PROPELLER (3X10-3/8"X13"-G) HELICE (3X10-3/8"X13"-G)	1	1	1	UR WITH LIP CUP UR WITH LIP CUP
	6H5-45952-00-EL	PROPELLER (3X10-5/8"X12"-G) HELICE (3X10-5/8"X12"-G)	1	1	1	UR WITH LIP CUP UR WITH LIP CUP
	6H5-45958-00-EL	PROPELLER (3X10-1/4"X14"-G) HELICE (3X10-1/4"X14"-G)	1	1	1	UR WITH LIP CUP UR WITH LIP CUP
	663-45930-00-98	PROPELLER (3X10-1/4"X14"-G) HELICE (3X10-1/4"X14"-G)	1	1	1	UR UR
	663-45974-02-98	PROPELLER (3X10-5/8"X13"-G) HELICE (3X10-5/8"X13"-G)	1	1	1	UR UR
	663-45976-00-98	PROPELLER (3X10-1/4"X15"-G) HELICE (3X10-1/4"X15"-G)	1	1	1	UR UR
	663-45978-00-98	PROPELLER (3X10-1/4"X16"-G) HELICE (3X10-1/4"X16"-G)	1	1	1	UR UR
	697-45970-00-98	PROPELLER (3X11-1/4"X14"-G) HELICE (3X11-1/4"X14"-G)	1	1	1	UR UR
	663-45970-60-98	PROPELLER (3X11-3/4"X12"-G) HELICE (3X11-3/4"X12"-G)	1	1	1	UR UR
	663-45972-60-98	PROPELLER (3X12"X11"-G) HELICE (3X12"X11"-G)	1	1	1	UR UR
	663-45974-60-98	PROPELLER (3X11-1/2"X13"-G) HELICE (3X11-1/2"X13"-G)	1	1	1	UR UR

**B4**

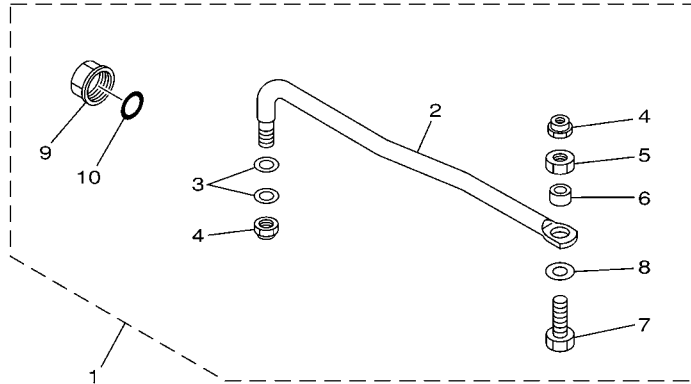


68U3300-C240

**FIG. 28 FUEL TANK**

**RESERVOIR A CARBURANT**

REF. NO.	PART NO. N° PIECES	DESCRIPTION DESCRIPTION	MFD	ED	ET	REMARKS REMARQUES
1	6YK-24201-01	FUEL TANK ASSY (25L) RESERVOIR A ESSENCE (ENS.) 25L	1	1	1	AP AP
	6YK-24201-10	FUEL TANK ASSY (25L) RESERVOIR A ESSENCE (ENS.) 25L	1	1	1	AP AP
2	6YL-24268-01	.GASKET, FUEL METER .JOINT, JAUGE A CARBURANT	1	1	1	
3	6YK-24610-00	.CAP ASSY .BOUCHON	1	1	1	WITH INDICATOR WITH INDICATOR
	6YK-24610-10	.CAP ASSY .BOUCHON	1	1	1	FOR SAV FOR SAV
4	6YL-24641-00	.GASKET, CAP 1 .JOINT 1, BOUCHON	1	1	1	
5	6YK-24260-01	.FUEL METER ASSY .INDICATEUR DE CARBURANT	1	1	1	
6	90157-05M16	.SCREW, PAN HEAD .VIS, TETE TRONCONIQUE	4	4	4	
7	6YL-24329-00	.SEAL .JOINT	4	4	4	
8	6YL-24306-53	FUEL PIPE COMP. 1 DURITE A ESSENCE 1	1	1	1	AP AP



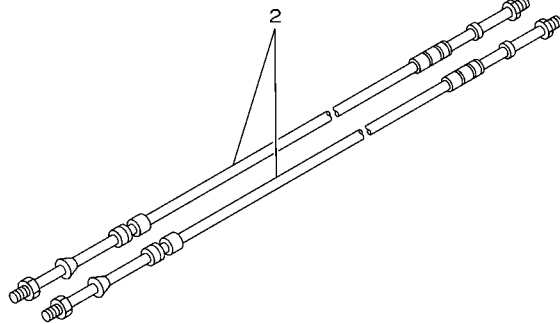
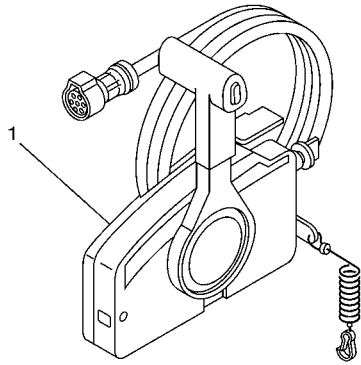
65W0010-8210

**FIG. 29 STEERING GUIDE**

**FIXATION DE DIRECTION**

REF. NO.	PART NO. N° PIECES	DESCRIPTION DESCRIPTION	MFD	ED	ET	REMARKS REMARQUES
1	65W-61350-00	STEERING GUIDE ATTACHMENT KIT FIXATIONS DE DIRECTION		1	1	AP
2	65W-61351-00	.ROD, STEERING LINK .RENOI DE DIRECTION		1	1	AP
3	90201-10M20	.WASHER, PLATE .RONDELLE, PLATE		2	2	
4	90185-09M01	.NUT, SELF-LOCKING .ECROU, AUTO-BLOCANT		2	2	
5	90170-09M03	.NUT .ECROU		1	1	
6	90387-10M42	.COLLAR .COLLERETTE		1	1	
7	90101-09M01	.BOLT .BOULON		1	1	
8	90201-10M63	.WASHER, PLATE .RONDELLE, PLATE		1	1	
9	6E5-43145-01	.CAP CLAMP BRACKET .CAPUCHON, PRESSE		1	1	
10	93210-16275	.O-RING .JOINT TORIQUE		1	1	

**B6**

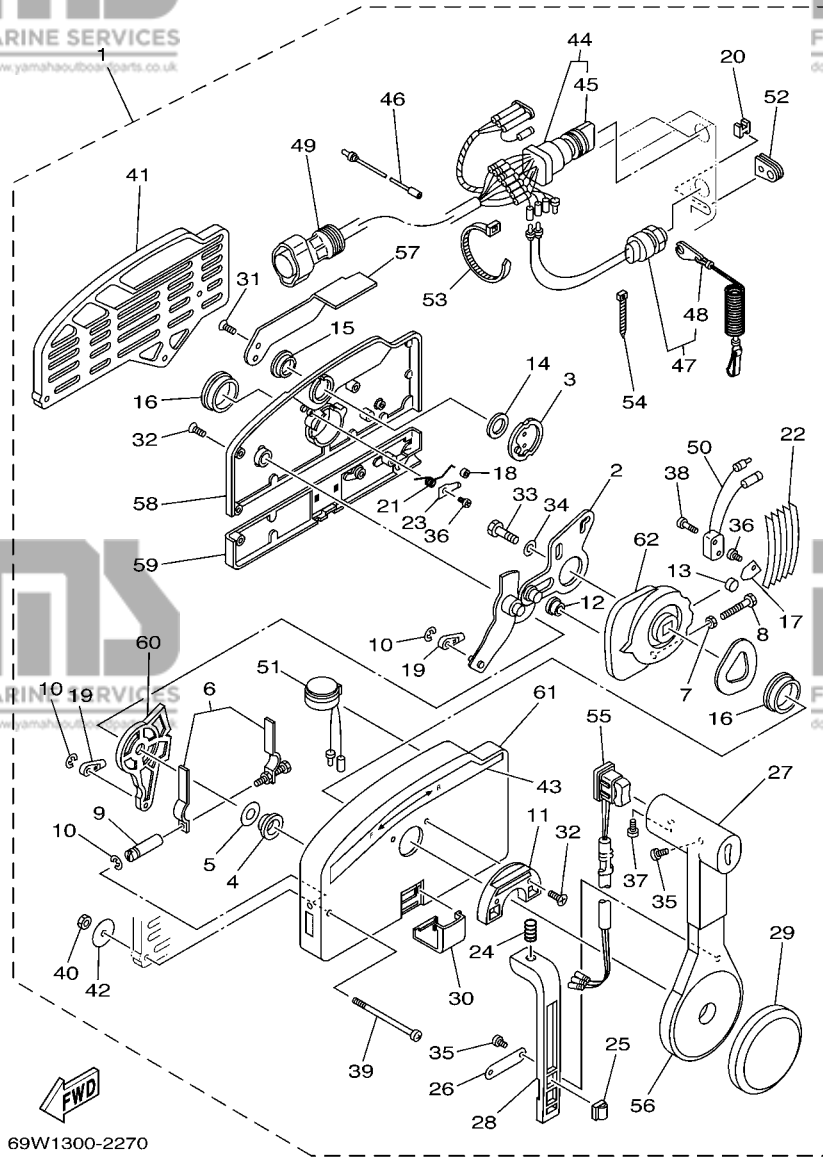


67M0100-8280

**FIG. 30 REMOTE CONTROL BOX**

**BOITIER DE COMMANDE A DISTANCE**

REF. NO.	PART NO. N° PIECES	DESCRIPTION DESCRIPTION	MFD	ED	ET	REMARKS REMARQUES
1	703-48207-17	REMOTE CONTROL ASSY BOITIER DE COMMANDE A DISTANCE		1	1	AP WITH PT/T SW. AP WITH PT/T SW.
2	701-48310-90	CABLE, REMOTE CONTROL L=11F CABLE, COMMANDE A DISTANCE:11F		2	2	UR UR
	701-48320-00	CABLE, REMOTE CONTROL L=12F CABLE, COMMANDE A DISTANCE:12F		2	2	UR UR
	701-48320-20	CABLE, REMOTE CONTROL L=13F CABLE, COMMANDE A DISTANCE:13F		2	2	UR UR
	701-48320-50	CABLE, REMOTE CONTROL L=15F CABLE, COMMANDE A DISTANCE:15F		2	2	UR UR



69W1300-2270

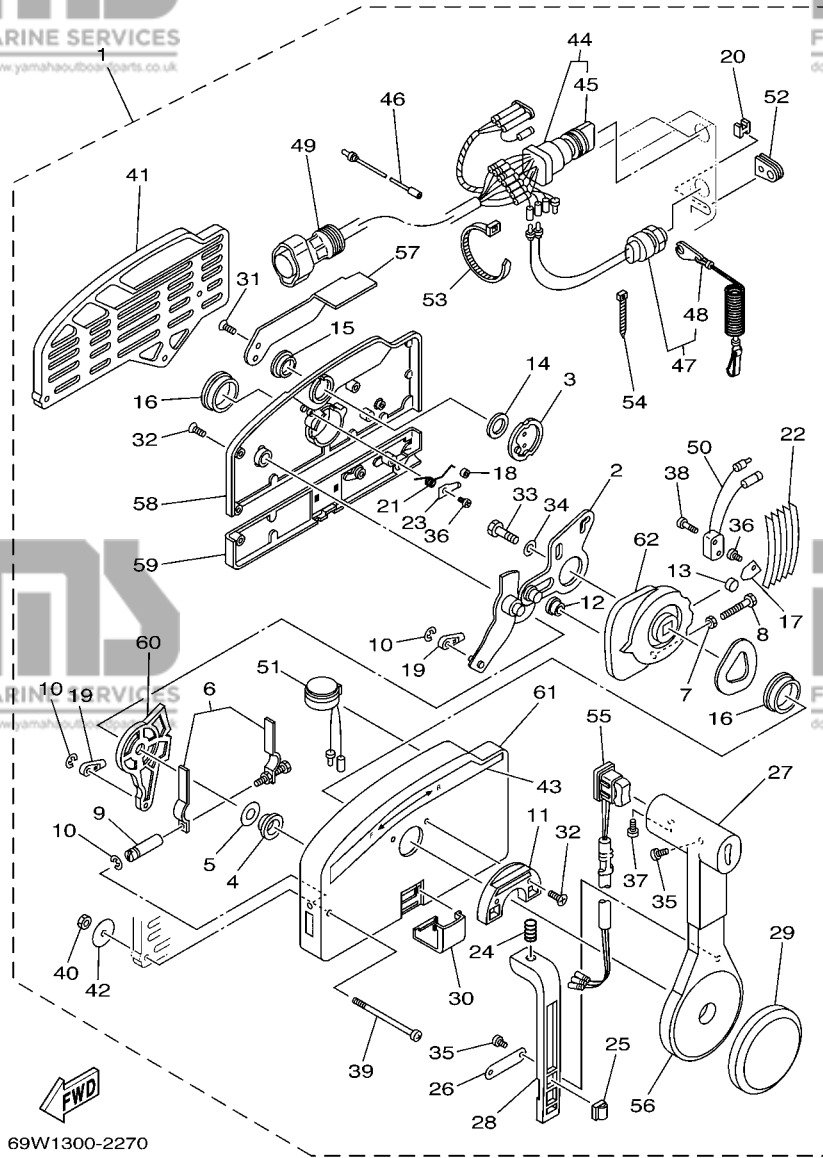
**FIG. 31 REMOTE CONTROL ASSY**

**BOITIER DE COMMANDE A DISTANCE**

REF. NO.	PART NO. N° PIECES	DESCRIPTION DESCRIPTION	MFD	ED	ET	REMARKS REMARQUES
1	703-48207-17	REMOTE CONTROL ASSY BOITIER DE COMMANDE A DISTANCE		1	1	AP WITH PT/T SW. AP WITH PT/T SW.
2	703-48261-01	.ARM, THROTTLE .BRAS, ACCELERATION		1	1	
3	703-48153-00	.SHAFT, FREE ACCEL. .AXE		1	1	
4	703-48235-00	.BUSHING .COUSSINET		1	1	
5	703-48268-00	.SPACER .ENTRETOISE		1	1	
6	703-48264-00	.THROTTLE, FRICTION .ACCELERATION		1	1	
7	95380-05600	.NUT .ECROU		1	1	
8	97380-05025	.BOLT .BOULON, HEXAGONAL		1	1	
9	703-48265-00	.SHAFT, FRICTION .AXE, COPILOTE		1	1	
10	93430-06024	.CIRCLIP .CLIPS		3	3	
11	703-48245-00	.PLATE, LOCK .PLAQUE, VERROU		1	1	
12	703-48252-00	.ROLLER, CAM .POULIE		1	1	
13	701-48248-00	.ROLLER, FREE ACCEL. .POULIE		1	1	
14	703-48198-00	.WASHER, WAVE .RONDELLE, ELASTIQUE ONDULEE		1	1	
15	703-48243-00	.BUSHING .COUSSINET		1	1	
16	703-48236-00	.BUSHING 1 .POULIE		2	2	
17	703-48189-00	.RETAINER .FLASQUE		1	1	
18	703-48234-00	.ROLLER, DETENT .POULIE		1	1	
19	703-48345-01	.CABLE END, REMOTE CONTROL 2 .CHAPE CABLE		2	2	
20	703-48358-00	.ANCHOR, CABLE .COLLIER		1	1	
21	703-48244-00	.SPRING, FREE ACCEL. .RESSORT		1	1	
22	703-48238-00	.SPRING, DETENT .RESSORT		5	5	
23	703-48246-00	.SPACER .ENTRETOISE		1	1	
24	703-48227-00	.SPRING, NEUTRAL LOCK .RESSORT		1	1	
25	703-82594-00	.CLAMP .BRIDE		1	1	WITH PT/T SW. WITH PT/T SW.
26	703-48226-00	.PLATE, STOPPER .PLAQUETTE		1	1	
27	703-48222-00	.GRIP, CONTROL LEVER .POIGNEE, COMMANDE LEVIER		1	1	SINGLE SINGLE

**C1**





69W1300-2270

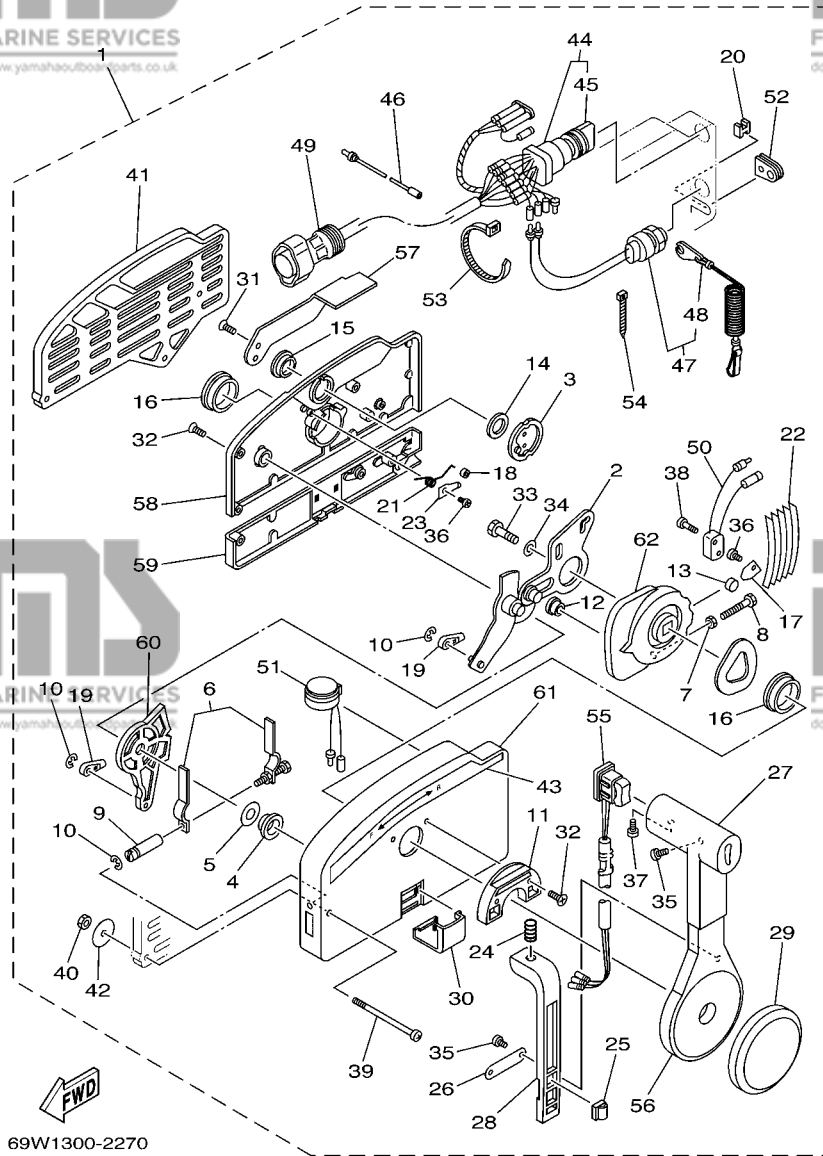
**FIG. 31 REMOTE CONTROL ASSY**

**BOITIER DE COMMANDE A DISTANCE**

REF. NO.	PART NO. N° PIECES	DESCRIPTION DESCRIPTION	MFD	ED	ET	REMARKS REMARQUES
28	703-48223-00	.LOCK, NEUTRAL .VERROU, NEUTRAL		1	1	
29	703-48225-00	.COVER .COUVERCLE		1	1	
30	703-48219-00	.COVER, LEAD .COUVERCLE		1	1	
31	703-48281-00	.SCREW .VIS		2	2	
32	703-48282-00	.SCREW .VIS		7	7	
33	97380-08030	.BOLT .BOULON, HEXAGONAL		1	1	
34	92990-08600	.WASHER, PLATE .RONDELLE, PLATE		1	1	
35	98580-04010	.SCREW, PAN HEAD .VIS		3	3	
36	98580-04006	.SCREW, PAN HEAD .VIS		2	2	
37	98580-05010	.SCREW, PAN HEAD .VIS		1	1	
38	98580-03015	.SCREW, PAN HEAD .VIS		2	2	
39	703-48291-10	.SCREW (M6) .VIS (M6)		3	3	
40	95380-06600	.NUT, HEXAGON .ECROU		3	3	
41	703-48293-10	.SPACER, REMOTE CONTROL .ENTRETOISE		1	1	SINGLE SINGLE
42	701-48287-00	.WASHER .RONDELLE		3	3	
43	703-48215-00	.GRAPHIC .ADHESIF		1	1	
44	703-82510-43	.MAIN SWITCH ASSY .CONTACTEUR A CLEF COMPLET		1	1	
45	703-82577-00	.CAP, KEY .CABOCHON		1	1	
46	703-82531-00	.WIRE, LEAD .FIL		1	1	
47	688-82575-01	.ENGINE STOP SWITCH ASSY .COUPE CIRCUIT CPLT		1	1	
48	682-82556-00	.STOPPER .PLAQUETTE		1	1	
49	688-8258A-20	.EXTENSION, WIRE HARNESS .EXTENSION, FAISCEAU DE FILS		1	1	L:5M (10P) L:5M (10P)
50	703-82540-00	.NEUTRAL SWITCH ASSY .CONTACTEUR DE POINT-MORT		1	1	
51	703-83383-02	.BUZZER .RONFLEUR		1	1	
52	703-48284-10	.GROMMET .PASSE-FIL		1	1	
53	703-82591-00	.BAND .COLLIER		3	3	
54	703-82592-00	.BAND .COLLIER		1	1	

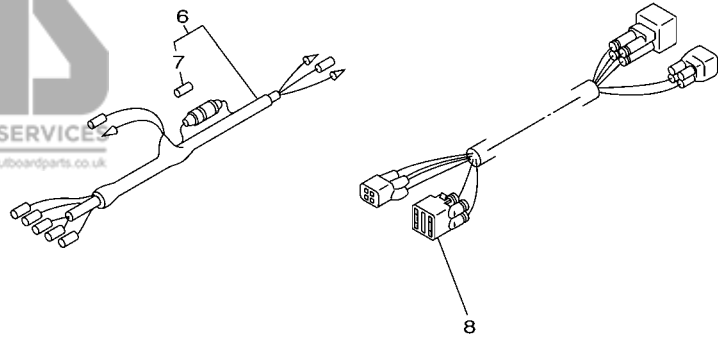
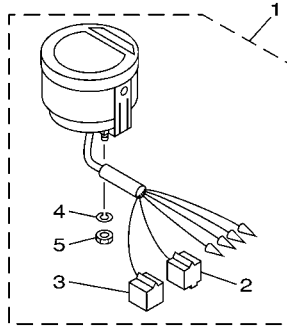
**FIG. 31 REMOTE CONTROL ASSY**

**BOITIER DE COMMANDE A DISTANCE**



69W1300-2270

REF. NO.	PART NO. N° PIECES	DESCRIPTION DESCRIPTION	MFD	ED	ET	REMARKS REMARQUES
55	703-82563-12	.TRIM & TILT SWITCH ASSY .INCLINER ET PARER COMMUTATEUR		1	1	
56	703-48221-00	.LEVER, CONTROL .LEVIER, COMMANDE		1	1	
57	703-48152-00	.KNOB, FREE ACCEL. .BOUTON		1	1	
58	703-48212-00	.BACK PLATE 1 .PLAQUETTE 1		1	1	
59	703-48213-00	.BACK PLATE 2 .PLAQUETTE 2		1	1	
60	703-48271-00	.ARM, SHIFT .BRAS		1	1	
61	703-48211-01	.HOUSING,1 .CORPS		1	1	
62	703-48232-00	.GEAR .PIGNON		1	1	



69W1300-2280

FIG. 32 METER

COMPTEUR

REF. NO.	PART NO. N° PIECES	DESCRIPTION DESCRIPTION	MFD	ED	ET	REMARKS REMARQUES
1	6Y5-8350T-03	TACHOMETER ASSY COMPTE-TOURS CPLT			1	AP AP
2	9E450-04433	.CONNECTOR .CONNECTEUR			1	M-4-W M-4-W
3	9E450-04533	.CONNECTOR .CONNECTEUR			1	F-4-W F-4-W
4	92990-04100	.WASHER, SPRING .RONDELLE, GROWER			2	
5	95380-04600	.NUT .ECROU			2	
6	6Y5-83553-00	WIRE, LEAD FIL			1	AP AP
7	1E6-82151-00	.FUSE (10A) .FUSIBLE (10A)			1	
8	68F-82553-70	EXTENSION, WIRE LEAD EXTENSION, FAISCEAU			1	AP AP

**C4**

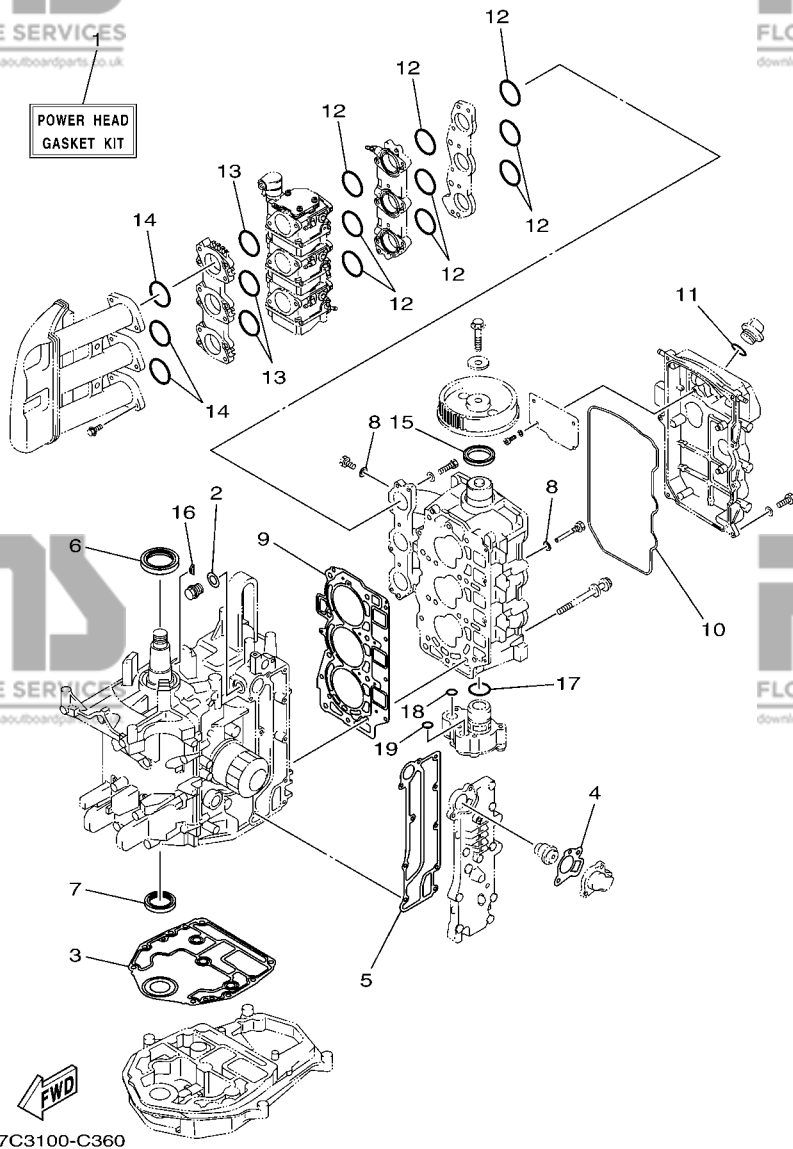
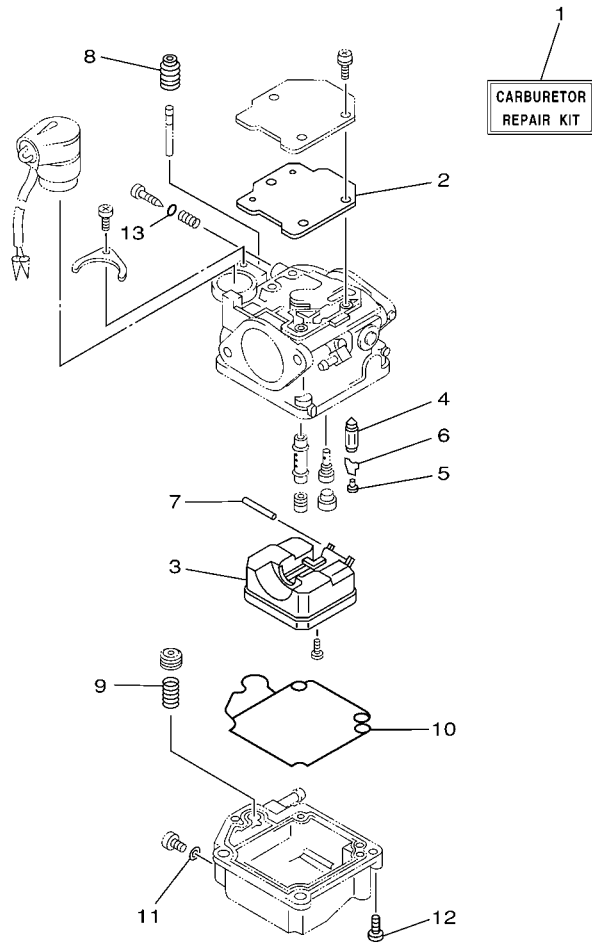


FIG. 33 REPAIR KIT 1

KITS DE REPARATION 1

REF. NO.	PART NO. N° PIECES	DESCRIPTION DESCRIPTION	MHD	ED	ET	REMARKS REMARQUES
1	67C-W0001-01	POWER HEAD GASKET KIT POCHETTE DE JINTS TETE MOTRICE	1	1	1	
2	90430-14115	.GASKET .JOINT	1	1	1	
3	67C-11351-01	.GASKET, CYLINDER .JOINT, D'EMBASE	1	1	1	
4	62Y-12414-00	.GASKET, COVER .JOINT, COUVERCLE	1	1	1	
5	67C-41114-10	.GASKET, EXHAUST OUTER COVER .JOINT, COUVERCLE D'ECHAPPEMEN	1	1	1	
6	93102-43M42	.OIL SEAL .JOINT SPY	1	1	1	
7	93102-35M47	.OIL SEAL .JOINT SPY	1	1	1	
8	90430-06014	.GASKET .JOINT	4	4	4	
9	67C-11181-01	.GASKET, CYLINDER HEAD 1 .JOINT, DE CULASSE 1	1	1	1	
10	67C-11356-00	.SEAL, CYLINDER 2 .JOINT, SPY CYLINDRE	1	1	1	
11	93210-24M79	.O-RING .JOINT TORIQUE	2	2	2	
12	67C-14561-00	.O-RING .JOINT TORIQUE	9	9	9	
13	67C-14562-00	.O-RING .JOINT TORIQUE	3	3	3	
14	93210-34MJ6	.O-RING .JOINT TORIQUE	3	3	3	
15	93102-37M40	.OIL SEAL .JOINT SPY	1	1	1	
16	90280-04M06	.KEY, WOODRUFF .CLAVETTE, DEMI-LUNE	1	1	1	
17	93210-33MH2	.O-RING .JOINT TORIQUE	1	1	1	
18	93210-12MG9	.O-RING .JOINT TORIQUE	1	1	1	
19	93210-14515	.O-RING .JOINT TORIQUE	1	1	1	

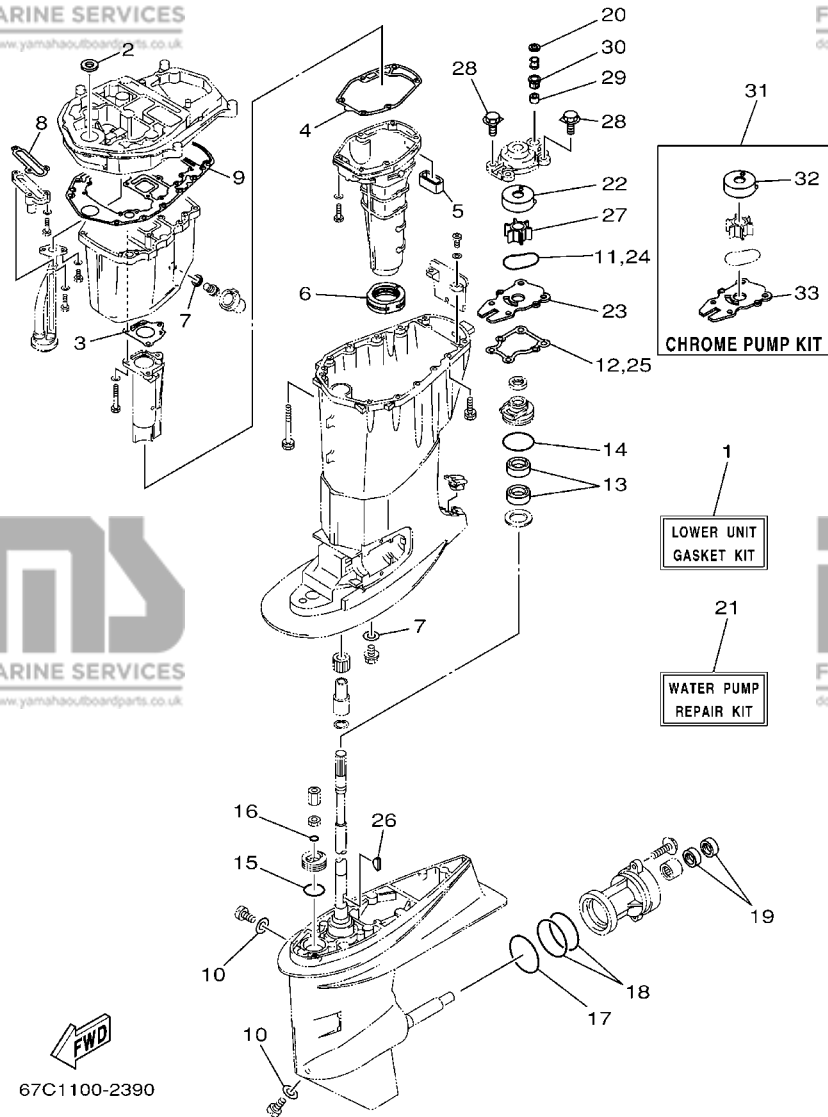


67C0100-0360

FIG. 34 REPAIR KIT 2

KITS DE REPARATION 2

REF. NO.	PART NO. N° PIECES	DESCRIPTION DESCRIPTION	MHD	ED	ET	REMARKS REMARQUES
1	67C-W0093-00	CARBURETOR REPAIR KIT KIT DE REPARATION CARBURATEUR	1	1	1	
2	65W-14126-10	.GASKET .JOINT	1	1	1	
3	63V-14985-00	.FLOAT .FLOTTEUR	1	1	1	
4	6G1-14546-01	.VALVE, NEEDLE .POINTEAU	1	1	1	
5	676-14186-00	.PIN, FLOAT .AXE, FLOTTEUR	1	1	1	
6	663-14159-00	.CLIP .JONC	1	1	1	
7	6H4-14548-00	.PIN, FLOAT ARM .AXE, BRAS DE FLOTTEUR	1	1	1	
8	65W-14373-00	.COVER, PLUNGER CAP .COUVERCLE DE PLONGEUR	1	1	1	
9	65W-14335-00	.SPRING, PLUNGER .RESSORT, PLONGEUR	1	1	1	
10	65W-14384-00	.GASKET, FLOAT CHAMBER .JOINT, CUVE DE FLOTTEUR	1	1	1	
11	65W-14398-00	.GASKET .JOINT	1	1	1	
12	97980-04114	.SCREW, WITH WASHER .VIS, AVEC RONDELLE	4	4	4	
13	67C-14397-00	.O-RING .JOINT TORIQUE	1	1	1	



67C1100-2390

FIG. 35 REPAIR KIT 3

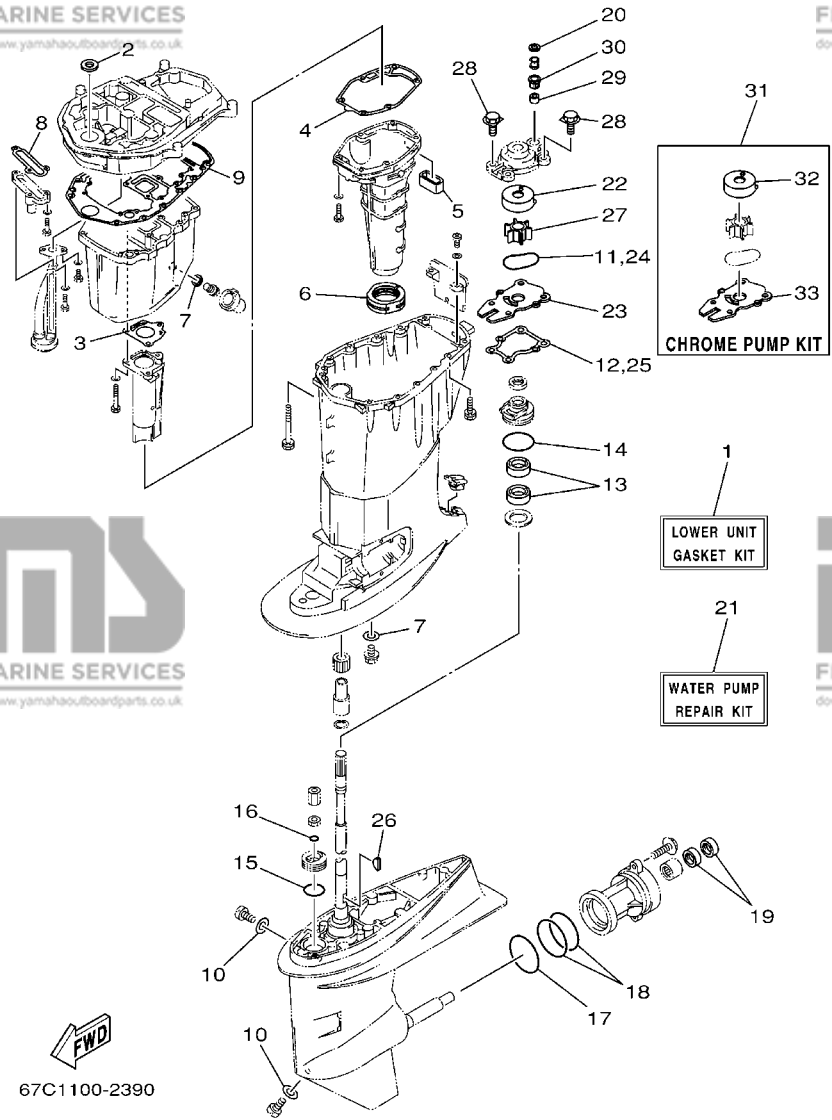
KITS DE PERARATION 3

REF. NO.	PART NO. N° PIECES	DESCRIPTION DESCRIPTION	MHD	ED	ET	REMARKS REMARQUES
1	67C-W0001-22	LOWER UNIT GASKET KIT POCHETTE DE JOINTS EMBASE	1	1	1	
2	93110-16004	.OIL SEAL .JOINT D'HUILE	1	1	1	
3	67C-41133-00	.GASKET, EXHAUST MANIFOLD 1 .JOINT, PIPE D'ECHAPPEMENT	1	1	1	
4	62Y-41134-01	.GASKET, EXHAUST MANIFOLD .JOINT, PIPE D'ECHAPPEMENT	1	1	1	
5	62Y-45127-00	.SEAL .JOINT	1	1	1	
6	67C-45123-00	.GASKET, MUFFLER .JOINT, POT DE DETENTE	1	1	1	
7	90430-14M09	.GASKET .JOINT	2	2	2	
8	62Y-13475-00	.GASKET .JOINT	1	1	1	
9	69W-15312-00	.GASKET, OIL PAN .JOINT DE VENTILATEUR D'HUILE	1	1	1	
10	90430-08020	.GASKET .JOINT	2	2	2	
11	93210-59MG7	.O-RING .JOINT TORIQUE	1	1	1	
12	63D-44316-00	.GASKET, WATER PUMP .JOINT, POMPE A EAU	1	1	1	
13	93101-22M60	.OIL SEAL .JOINT SPY	2	2	2	
14	93210-48MG8	.O-RING .JOINT TORIQUE	1	1	1	
15	93210-33MG4	.O-RING .JOINT TORIQUE	1	1	1	
16	93210-06ME6	.O-RING .JOINT TORIQUE	1	1	1	
17	93210-69MG6	.O-RING .JOINT TORIQUE	1	1	1	
18	93210-74MG5	.O-RING .JOINT TORIQUE	2	2	2	
19	93101-22M00	.OIL SEAL .JOINT SPY	2	2	2	
20	90430-12072	.GASKET .JOINT	1	1	1	
21	66T-W0078-00	WATER PUMP REPAIR KIT KIT DE REPARATION DE LA POMPE	1	1	1	
22	63D-44322-00	.INSERT, CARTRIDGE .CUVETTE	1	1	1	
23	66T-44323-00	.OUTER PLATE, CARTRIDGE .PLAQUE EXTERIEURE	1	1	1	
24	93210-59MG7	.O-RING .JOINT TORIQUE	1	1	1	
25	63D-44316-00	.GASKET, WATER PUMP .JOINT, POMPE A EAU	1	1	1	
26	90280-03M03	.KEY, WOODRUFF .CLAVETTE, DEMI-LUNE	1	1	1	
27	6H4-44352-02	.IMPELLER .TURBINE	1	1	1	

FIG. 35 REPAIR KIT 3

KITS DE PERAPATION 3

REF. NO.	PART NO. N° PIECES	DESCRIPTION DESCRIPTION	MFD	ED	ET	REMARKS REMARQUES
28	90119-08M15	.BOLT, WITH WASHER .BOULON, AVEC RONDELLE	4	4	4	
29	663-44366-00	.DAMPER, WATER SEAL .JOINT, TUBE D'EAU	1	1	1	
30	63D-44312-00	.COVER, WATER PUMP HOUSING .COUVERCLE	1	1	1	
31	66T-W0078-0A	CHROME PUMP KIT KIT DE POMPE A EAU CHROMEE	1	1	1	
32	63D-44322-40	.INSERT, CARTRIDGE .CUVETTE	1	1	1	
33	66T-44323-40	.OUTER PLATE, CARTRIDGE .PLAQUE EXTERIEURE	1	1	1	



D1

PART NO. N° PIECES	REF. NO.
67C-11111-03-1S	4 - 2
67C-11111-12-1S	4 - 2
65W-11119-00	2 - 11
62Y-11133-10	4 - 3
67C-11168-00	4 - 24
67C-11181-01	4 - 15
	33 - 9
67C-11191-00-1S	4 - 19
62Y-11325-00	4 - 5
66M-11327-00-94	4 - 7
66M-11328-00	4 - 6
67C-11351-01	2 - 10
	33 - 3
67C-11356-00	4 - 21
	33 - 10
62Y-11372-01	2 - 25
67C-11411-00	3 - 3
62Y-11416-00	3 - 4
62Y-11416-10	3 - 4
62Y-11416-20	3 - 4
65W-11476-00	8 - 9
65W-11536-10	8 - 8
67C-11537-01	8 - 3
65W-11545-00	11 - 5
62Y-11575-00	25 - 2
67C-11603-00	3 - 9
67C-11604-00	3 - 9
67C-11605-00	3 - 9
65W-11631-00-96	3 - 8
62Y-11633-00-00	3 - 10
65W-11635-00	3 - 8
65W-11636-00	3 - 8
62Y-11650-10	3 - 5
62Y-11654-00	3 - 6
62Y-11656-00	3 - 7
62Y-11656-10	3 - 7
62Y-11656-20	3 - 7
67C-12111-00	5 - 1
67C-12113-00	5 - 15
51Y-12114-00	5 - 4
62Y-12116-00	5 - 3
30X-12117-00	5 - 5
30X-12118-00	5 - 6
51Y-12119-00	5 - 7
62Y-12121-00	5 - 2
62Y-12138-60	4 - 33
67C-12146-00	5 - 8
65W-12151-00	5 - 9

PART NO. N° PIECES	REF. NO.
62Y-12158-00	5 - 11
62Y-12159-00	5 - 10
67C-12170-11	8 - 2
67C-12171-00	8 - 2
62Y-12216-00	5 - 14
62Y-12231-00	5 - 17
62Y-12238-00	5 - 12
64J-12238-00	5 - 12
62Y-12279-00	5 - 13
64J-12279-00	5 - 13
6G8-12411-02	2 - 13
6H3-12413-00-1S	2 - 14
62Y-12414-00	2 - 15
	33 - 4
66M-12535-00	4 - 8
69W-12535-00	17 - 41
68T-12572-00	17 - 40
6R3-12580-00	17 - 46
62Y-13131-01	9 - 5
69W-13300-00	8 - 11
62Y-13411-00	25 - 6
67F-13434-02	1 - 16
62Y-13437-61	10 - 42
	11 - 15
5GH-13440-00	2 - 26
62Y-13444-50	17 - 51
62Y-13475-00	25 - 3
	35 - 8
67C-13589-00	6 - 4
67C-13971-00	6 - 11
67C-13972-00	6 - 12
67C-13973-00	6 - 13
67C-13974-00	6 - 14
	7 - 40
67C-13975-00	6 - 15
67C-13976-00	6 - 16
65W-14126-10	7 - 5
	34 - 2
663-14159-00	7 - 16
	34 - 6
676-14186-00	7 - 15
	34 - 5
67C-14242-00	7 - 46
67C-14243-01-94	6 - 8
67C-14245-00	7 - 45
67C-14255-00	6 - 18
67C-14271-00	6 - 5
67C-14318-00	6 - 17

PART NO. N° PIECES	REF. NO.
67C-14325-00	7 - 44
65W-14335-00	7 - 21
	34 - 9
65W-14346-00	7 - 34
67C-14356-00	7 - 42
67C-14369-00	7 - 37
67C-14371-00	7 - 22
65W-14373-00	7 - 19
	34 - 8
67C-14379-00	7 - 20
67C-14379-10	7 - 20
67C-14380-00	7 - 35
65W-14384-00	7 - 23
	34 - 10
67C-14397-00	7 - 30
	34 - 13
65W-14398-00	7 - 26
	34 - 11
67C-14398-00	7 - 43
67C-14440-00	6 - 24
62Y-14485-00	4 - 20
63V-14523-00	7 - 10
6G1-14546-01	7 - 14
	34 - 4
6H4-14548-00	7 - 18
	34 - 7
67C-14555-00	7 - 31
67C-14561-00	6 - 7
	33 - 12
67C-14562-00	6 - 10
	33 - 13
67C-14567-00	7 - 36
65W-14572-00	7 - 4
67C-14585-00	6 - 3
67C-14711-00-5B	24 - 7
67C-14711-12-5B	24 - 7
69H-14901-02	7 - 1
67C-14901-03	7 - 1
69H-14901-22	7 - 1
67C-14901-23	7 - 1
69H-14902-02	7 - 2
67C-14902-03	7 - 2
69H-14902-22	7 - 2
67C-14902-23	7 - 2
69H-14903-02	7 - 3
67C-14903-03	7 - 3
69H-14903-22	7 - 3
67C-14903-23	7 - 3

PART NO. N° PIECES	REF. NO.
67C-14923-00	7 - 29
67C-14923-20	7 - 29
69H-14943-22	7 - 12
67C-14943-25	7 - 12
67C-14947-00	7 - 11
69H-14947-00	7 - 11
67C-14948-00	7 - 7
67C-14948-01	7 - 11
67C-14948-02	7 - 7
679-14966-00	7 - 8
67C-14974-00	7 - 41
67C-14980-00	7 - 24
69H-14980-00	7 - 24
67C-14981-00	7 - 25
69H-14981-00	7 - 25
67C-14982-00	7 - 32
69H-14982-00	7 - 32
63V-14985-00	7 - 13
	34 - 3
65W-14992-00	7 - 27
67C-14992-00	7 - 33
67C-15100-01-94	2 - 2
62Y-15311-02-5B	25 - 10
69W-15312-00	25 - 11
	35 - 9
67C-15316-00	25 - 13
67C-15316-10	25 - 13
67C-15362-00	25 - 1
6G8-15363-00	4 - 31
67C-15373-00	6 - 31
66T-15705-00	10 - 7
67C-15710-00	10 - 1
67C-15711-00	10 - 2
66T-15713-00	10 - 5
66T-15714-00	10 - 3
66T-15716-00	10 - 6
67C-15723-00	10 - 29
66T-15731-00	10 - 39
66T-15734-00	10 - 14
63V-15741-00	10 - 4
63V-15744-00	10 - 10
6F5-15752-00	10 - 16
6F5-15753-00	10 - 17
689-15755-01	10 - 26
67C-15758-00	10 - 21
67C-15762-00	10 - 22
66T-15767-00	10 - 8
63V-15768-00	10 - 11

PART NO. N° PIECES	REF. NO.
67C-15770-00	10 - 38
66M-15774-00	10 - 36
6F5-15779-02	10 - 27
66T-15784-00	10 - 9
6A0-15789-00	10 - 28
6F5-15791-00	10 - 15
66T-15794-00	10 - 13
6G8-2415E-00	17 - 50
6YK-24201-01	28 - 1
6YK-24201-10	28 - 1
65W-24251-00	9 - 21
6YK-24260-01	28 - 5
6YL-24268-01	28 - 2
6G1-24304-02	9 - 25
6YL-24306-53	28 - 8
67C-24312-00	17 - 44
61N-24329-00	17 - 28
6YL-24329-00	28 - 7
62Y-24374-01	9 - 11
688-24378-00	2 - 17
62Y-24410-03	9 - 1
62Y-24411-02	9 - 3
62Y-24415-00	9 - 2
62Y-24423-00	9 - 4
62Y-24444-01	9 - 7
62Y-24452-00	9 - 9
62Y-24454-00	9 - 6
62Y-24471-00	9 - 8
65W-24474-00	9 - 13
6YK-24610-00	28 - 3
6YK-24610-10	28 - 3
6YL-24641-00	28 - 4
69W-26301-00	18 - 36
62Y-28100-00	9 - 29
67F-2812A-00	13 - 20
6A1-28176-00	17 - 48
67C-28199-74-A0	9 - 30
67C-28199-74-B0	9 - 30
67C-28199-85-A0	9 - 31
67C-28199-85-B0	9 - 31
61H-2819R-31	9 - 28
67C-41113-01-1S	2 - 24
67C-41114-10	2 - 22
	33 - 5
67C-41131-00-5B	24 - 3
67C-41133-00	24 - 4
	35 - 3
62Y-41134-01	24 - 10

PART NO. N° PIECES	REF. NO.
62Y-41134-01	35 - 4
67C-41137-01-94	24 - 1
67C-41212-00	19 - 22
67C-41213-20	19 - 28
6E9-41237-00	19 - 20
6F5-41237-00	19 - 21
67C-41241-00	19 - 19
6F5-41662-00	19 - 4
67G-42111-00-4D	18 - 10
69W-42115-10	18 - 14
69W-42119-00	18 - 56
63D-42121-20-4D	18 - 2
63D-42126-00	18 - 52
67G-42131-00	18 - 46
6J0-42137-00	18 - 57
650-42152-00-94	18 - 15
67G-42153-00	18 - 21
67G-42159-00	18 - 17
62Y-42171-00	19 - 26
6G1-42177-00	18 - 59
67C-42510-01-4D	22 - 25
67C-42510-11-4D	22 - 25
6J8-42528-00	22 - 1
624-42542-00	14 - 12
67C-42610-20-4D	1 - 1
69H-42610-20-4D	1 - 1
67C-42610-30-4D	1 - 1
69H-42610-30-4D	1 - 1
67C-42613-00-4D	1 - 2
67C-42613-10-4D	1 - 2
67C-42615-00	1 - 14
61N-42628-00	1 - 15
62Y-42651-00	1 - 4
67C-42652-00	1 - 6
67C-42677-00	1 - 9
69H-42677-10	1 - 9
67C-42678-00	1 - 10
69H-42678-10	1 - 10
67C-42681-10	1 - 12
67C-42682-10	1 - 13
67C-42710-02-4D	17 - 1
67C-42710-12-4D	17 - 1
62Y-42716-00	17 - 5
65W-42717-00	17 - 6
65W-42724-10	17 - 22
62Y-42725-00	17 - 8
63D-42725-00	18 - 51
67C-42725-00	17 - 8





PART NO. N° PIECES	REF. NO.	PART NO. N° PIECES	REF. NO.
65W-8182B-00	13 - 10	6E3-8257H-00	17 - 49
65W-8182S-00	16 - 10	689-8257Y-00	15 - 3
65W-81830-00	16 - 4	6E5-82587-00	14 - 2
65W-81840-00	16 - 9	6E5-82588-00	17 - 38
67C-81850-00	16 - 6	688-8258A-20	31 - 49
65W-81857-01	16 - 3	67C-82590-00	13 - 15
65W-8191C-00	13 - 2	67C-82590-10	13 - 15
6H5-81920-00	14 - 15	67C-82590-20	13 - 15
65W-81922-00	13 - 3	703-82591-00	31 - 53
65W-81941-00	13 - 1	703-82592-00	31 - 54
67C-81948-00	14 - 10	67C-82594-00	13 - 28
67C-81949-00	14 - 18	703-82594-00	31 - 25
67C-81949-10	14 - 19	703-83383-03	31 - 51
6H1-81950-00	14 - 6	6Y5-8350T-02	32 - 1
65W-81960-10	12 - 16	6Y5-83553-00	32 - 6
67C-82105-00	13 - 11	6E5-83558-00	22 - 22
65W-82117-00	13 - 8	6E5-83558-10	26 - 14
6G5-82119-00	14 - 20	6H4-83589-00	15 - 7
703-82119-00	22 - 7	62Y-83614-00	14 - 3
6G5-82119-10	13 - 9	6A1-83625-41	10 - 43
65W-82127-00	13 - 36		11 - 16
67C-82127-00	22 - 19	6A1-83625-51	10 - 44
6U0-82127-00	21 - 36		11 - 17
67C-82127-10	22 - 19	6E0-83627-41	18 - 64
67C-82127-20	20 - 37	6E0-83627-51	18 - 65
6H1-82148-00	21 - 25	64E-83672-02	22 - 5
1E6-82151-00	32 - 7	62Y-84301-00	15 - 6
67F-82151-00	13 - 16	67C-85415-00	17 - 37
6A0-82317-00	14 - 11	65W-85510-00	11 - 2
6G8-82370-30	12 - 11	65W-85510-10	11 - 2
62Y-82377-00	17 - 47	67C-85540-01	12 - 1
65W-82504-00	13 - 35	67C-85542-00	12 - 4
67C-82509-00	13 - 4	65W-85547-00	12 - 5
703-82510-43	31 - 44	65W-85550-01	11 - 1
67C-82519-00	13 - 30	65W-85550-11	11 - 1
65W-8252V-00	12 - 3	67C-85554-00	12 - 8
67C-8252V-00	12 - 7	67C-85570-00	12 - 9
703-82531-00	31 - 46	65W-85580-00	11 - 3
65W-82532-00	13 - 37	67C-85790-00	13 - 38
703-82540-00	31 - 50	65W-86129-00	12 - 2
68F-82553-70	32 - 8	65W-86129-10	12 - 6
682-82556-00	15 - 2	67C-W0001-01	33 - 1
	31 - 48	67C-W0001-22	35 - 1
	14 - 1	67C-W0070-10	1 - 11
63D-82563-10	14 - 1	66T-W0078-00	35 - 21
703-82563-12	31 - 55	66T-W0078-0A	35 - 31
688-82575-01	31 - 47	69W-W0084-10-4D	18 - 1
6K5-82575-03	15 - 1	67C-W0093-00	34 - 1
703-82577-00	31 - 45		

PART NO. N° PIECES	REF. NO.	PART NO. N° PIECES	REF. NO.
67C-W009A-01-1S	4 - 1	90167-06002	17 - 42
67C-W009A-11-1S	4 - 1	90170-09M03	29 - 5
67C-W009B-02-1S	2 - 1	90170-12138	26 - 41
90101-06020	20 - 36	90170-20137	11 - 6
	21 - 34	90171-16011	27 - 23
90101-08M15	22 - 27	90179-06M24	1 - 3
90101-09M01	29 - 7	90185-08045	22 - 29
90101-12M09	18 - 3	90185-09M01	29 - 4
90101-12M65	20 - 40	90185-10051	22 - 11
	21 - 39	90185-10M13	20 - 33
90105-06M18	22 - 3		21 - 31
90105-08M61	26 - 54	90185-12M12	18 - 9
90105-08M87	2 - 12	90185-22M11	20 - 12
90109-06M65	4 - 14		17 - 13
90109-06M80	17 - 34	90201-05M06	19 - 14
90109-06M81	17 - 10	90201-08M00	20 - 24
	19 - 5		21 - 22
90109-06M86	10 - 37	90201-10M06	8 - 5
	14 - 4	90201-10M20	29 - 3
	17 - 19	90201-10M63	29 - 8
	19 - 7	90201-12426	20 - 42
90109-06MA1	10 - 33		21 - 41
90109-06MA2	15 - 9	90201-12M07	17 - 15
90109-06MA4	1 - 7	90201-12M16	14 - 14
90109-08M63	5 - 16		22 - 43
90109-12MA3	22 - 41	90201-13M19	22 - 45
90110-10M02	20 - 32	90201-21M18	11 - 7
	21 - 30	90201-22429	26 - 46
90116-10M28	22 - 10	90201-22M05	22 - 46
90119-06025	8 - 15	90201-27M00	26 - 27
90119-06M08	17 - 2	90201-30M00	22 - 13
90119-06M82	6 - 26	90202-12060	27 - 3
90119-06M86	6 - 27	90202-21100	22 - 44
90119-06M91	19 - 33	90206-12052	17 - 14
90119-06MA3	4 - 18	90206-12M22	18 - 5
90119-06MA5	2 - 23	90249-12M38	20 - 28
90119-08M01	2 - 4		21 - 26
90119-08M15	26 - 29	90249-18M35	20 - 22
	35 - 28		21 - 20
90119-08M39	16 - 11	90250-06023	26 - 57
90119-08M44	27 - 14	90254-03M05	19 - 3
90119-08M79	24 - 14	90266-06M02	1 - 5
90119-08M82	24 - 15	90269-02M09	18 - 58
90119-09M00	4 - 17	90280-03M03	26 - 21
90142-05M06	26 - 9		35 - 26
90149-05M13	18 - 63	90280-04M06	8 - 10
90157-05M16	28 - 6		33 - 16
90159-06M18	18 - 44	90338-04M17	6 - 6

PART NO. N° PIECES	REF. NO.	PART NO. N° PIECES	REF. NO.
90338-07004	17 - 23		
90340-08002	26 - 4		
90340-14M06	2 - 8		
	24 - 23		
	25 - 14		
90344-51M01	2 - 7		
90381-12M10	20 - 29		
	21 - 27		
90381-12M11	20 - 30		
	21 - 28		
90386-08032	18 - 60		
90386-12M37	17 - 12		
90386-12M93	18 - 7		
90386-12MA2	17 - 13		
90386-14MA1	20 - 6		
	21 - 6		
90386-18M44	20 - 25		
	21 - 23		
90386-18MA0	21 - 24		
90386-18MA5	20 - 26		
90386-22MA4	20 - 14		
	21 - 18		
90386-26MA3	18 - 40		
90386-30M60	22 - 17		
90386-30M77	22 - 15		
90386-30M78	22 - 14		
90387-06060	17 - 4		
90387-06M29	19 - 23		
90387-06M43	17 - 36		
90387-06M70	6 - 30		
90387-06M87	15 - 8		
90387-06M88	19 - 29		
90387-06M89	10 - 25		
90387-10M42	29 - 6		
90387-12M02	18 - 6		
90387-18M03	20 - 27		
90387-23002	24 - 21		
90389-22M01	27 - 22		
90401-20M00	2 - 27		
90430-06014	4 - 13		
	33 - 8		
90430-08020	26 - 5		
	35 - 10		
90430-08143	4 - 29		
90430-12072	27 - 4		
	35 - 20		
90430-14115	2 - 9		
	33 - 2		

PART NO. N° PIECES	REF. NO.	PART NO. N° PIECES	REF. NO.
90430-14M09	24 - 24		
	25 - 15		
	35 - 7		
90445-07M53	22 - 21		
90445-07ME8	26 - 12		
90445-07MF1	22 - 21		
90445-09068	2 - 16		
90445-09095	2 - 18		
90445-09105	2 - 19		
90445-09M34	6 - 1		
90445-10MG6	9 - 18		
90445-10MH8	9 - 22		
90446-10M82	11 - 4		
90446-10M86	10 - 40		
90446-14M12	9 - 23		
90464-09M13	17 - 25		
90464-10M57	13 - 27		
90465-05M87	13 - 21		
90465-06M88	12 - 15		
	14 - 5		
90465-06M90	12 - 14		
	13 - 22		
90465-08M07	22 - 23		
90465-08M63	13 - 17		
	21 - 12		
90465-08M75	13 - 24		
	14 - 9		
90465-10M77	21 - 7		
90465-11M10	2 - 20		
	6 - 2		
	17 - 45		
	22 - 4		
	26 - 15		
90465-13M11	21 - 19		
90465-13M18	13 - 23		
90467-08004	2 - 21		
90467-09M03	9 - 20		
90467-09M17	9 - 17		
90467-10M04	9 - 16		
90467-15M14	6 - 32		
90468-10005	18 - 33		
	19 - 15		
90468-18008	19 - 9		
90480-06M19	15 - 10		
90480-09M12	17 - 3		
90480-10M16	10 - 34		
90480-12072	10 - 35		
90480-13M24	17 - 35		



FLOOD MARINE SERVICES  
downloaded from www.yamahaoutboardparts.co.uk

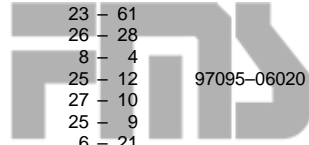
PART NO. N° PIECES	REF. NO.
90480-25161	12 - 10
90501-10326	7 - 9
90501-18M01	26 - 56
90501-23215	18 - 61
90506-18M40	17 - 20
90508-20M44	19 - 30
91318-04025	23 - 38
91380-05025	11 - 8
91380-05030	11 - 8
91490-06012	6 - 20
	7 - 39
91490-12010	19 - 27
91490-20010	18 - 55
91490-30025	27 - 24
91690-30018	20 - 5
	21 - 5
91690-30025	18 - 16
92903-06600	2 - 6
	25 - 5
92903-10600	18 - 62
92907-04600	4 - 26
92990-04100	32 - 4
92990-04600	6 - 19
	7 - 38
92990-05600	24 - 18
92990-06100	17 - 32
92990-06600	17 - 33
	26 - 36
92990-08600	31 - 34
92990-12200	18 - 4
92990-12600	18 - 8
92995-05600	4 - 10
	11 - 10
92995-06600	4 - 12
	6 - 23
	9 - 15
	10 - 20
	11 - 13
	12 - 13
	13 - 7
	14 - 8
	15 - 5
	18 - 27
	20 - 39
	21 - 9
	24 - 6
	25 - 17
92995-08100	20 - 11



FLOOD MARINE SERVICES  
downloaded from www.yamahaoutboardparts.co.uk

NUMERICAL INDEX  
INDEX NUMERIQUE

PART NO. N° PIECES	REF. NO.
93210-48MG8	26 - 26
	35 - 14
93210-50768	23 - 29
93210-59MG7	26 - 19
	35 - 11
93210-69MG6	26 - 50
	35 - 17
93210-74MG5	26 - 51
	35 - 18
93306-001U1	26 - 49
93315-32224	26 - 11
93317-22204	26 - 52
93332-00001	26 - 38
93332-00003	26 - 43
93410-28M06	22 - 18
93420-36M01	24 - 22
93430-06024	31 - 10
93430-10M00	20 - 31
	21 - 29
93450-09M01	4 - 4
93450-17129	3 - 11
93501-08001	23 - 61
93604-08062	26 - 28
93605-14143	8 - 4
93606-12019	25 - 12
	27 - 10
93608-12M05	25 - 9
93608-16M16	6 - 21
93700-06M03	20 - 8
	21 - 11
94701-00375	4 - 34
95380-04600	32 - 5
95380-05600	9 - 10
	26 - 10
	31 - 7
95380-06600	17 - 30
	18 - 54
	31 - 40
95380-06700	1 - 8
	26 - 32
95380-12600	20 - 43
	21 - 42
95380-12700	22 - 42
95780-06300	19 - 25
95895-06030	14 - 13
95895-10040	8 - 6
97013-06016	25 - 7
97013-06025	25 - 4



FLOOD MARINE SERVICES  
downloaded from www.yamahaoutboardparts.co.uk

PART NO. N° PIECES	REF. NO.
97013-06035	2 - 5
97075-06025	24 - 8
	25 - 16
97075-06050	24 - 5
97075-08030	22 - 30
97075-10040	27 - 11
97080-08016	20 - 23
	21 - 21
97085-06010	21 - 35
97095-05012	4 - 9
	13 - 29
97095-05016	11 - 9
97095-06010	4 - 27
	10 - 30
	20 - 18
97095-06012	12 - 17
	13 - 13
	14 - 16
	15 - 4
	17 - 17
	18 - 28
97095-06014	19 - 32
	20 - 38
	21 - 8
97095-06020	4 - 11
	6 - 28
	12 - 12
	14 - 7
	6 - 22
	9 - 26
	10 - 19
	11 - 12
	19 - 24
97095-06030	9 - 14
	13 - 6
	18 - 26
97095-06040	12 - 17
97095-08012	13 - 31
97095-08014	4 - 30
97095-08020	20 - 10
	21 - 14
	22 - 35
97095-08025	27 - 8
97095-08035	27 - 16
97095-08040	18 - 41
97380-05025	31 - 8
97380-08030	31 - 33
97523-06425	10 - 18



FLOOD MARINE SERVICES  
downloaded from www.yamahaoutboardparts.co.uk

PART NO. N° PIECES	REF. NO.
97595-06590	6 - 9
97780-60525	22 - 9
97803-04010	7 - 6
97880-05016	24 - 17
97880-06025	17 - 31
97885-06008	22 - 20
97885-06016	18 - 47
	22 - 6
97885-06040	18 - 49
97980-04114	7 - 28
	34 - 12
98507-04010	4 - 25
98580-03015	31 - 38
98580-04006	31 - 36
98580-04008	7 - 17
98580-04010	31 - 35
98580-05010	31 - 37
98680-06525	20 - 21
98785-05014	18 - 24
99530-08012	2 - 3
	4 - 16
9E450-04433	32 - 2
9E450-04533	32 - 3



FLOOD MARINE SERVICES  
downloaded from www.yamahaoutboardparts.co.uk



FLOOD MARINE SERVICES  
downloaded from www.yamahaoutboardparts.co.uk



FLOOD MARINE SERVICES  
downloaded from www.yamahaoutboardparts.co.uk



FLOOD MARINE SERVICES  
downloaded from www.yamahaoutboardparts.co.uk

F30A/F40B  
PARTS CATALOGUE  
©2003 by Yamaha Motor Co., Ltd.  
1st edition, May 2003  
All rights reserved.  
Any reprinting or unauthorized use  
without the written permission of  
Yamaha Motor Co., Ltd.  
is expressly prohibited.  
Printed in Japan.

F30A/F40B  
CATALOGUE DE PIÈCES DÉTACHÉES  
©2003 par Yamaha Motor Co., Ltd.  
1<sup>re</sup> édition, mai 2003  
Tous droits réservés  
Toute réimpression ou utilisation  
non autorisée sans la permission écrite  
de la Yamaha Motor Co., Ltd.  
est formellement interdite.  
Imprimé au Japon