

# PARTS CATALOGUE CATALOGUE DE PIECES DETACHEES

## F4AMH'03(68D3)

1B68D-300F1

**YAMAHA**  
**GENUINE**  
Parts & Accessories

2005/11/30

NEWS NO.	DATE	COMMENT
PE0-OM-040001	October,25,2004	COR:FIG.9 REF.28 NUT P/No. CORRECTION

# FOREWORD

This Parts Catalogue is related to the parts for the model(s) in the below frame. When you are ordering replacement parts, please refer to this Parts Catalogue and quote both part numbers and part names correctly.

F4AMH'03(68D3)

1. Modifications or additions which have been made after issue of the Parts Catalogue will be announced in the Yamaha Parts News. It is advisable that you make necessary corrections to the Parts Catalogue according to the Yamaha Parts News.

2. Abbreviations  
The Following abbreviations are used in this Parts Catalogue.

“UR” Use specified parts number.

“UN” Use as many as needed.

“AP” Alternate Parts

“LM” Local Made  
(Parts need to be ordered locally)

“O/S” Over Size

3. Parts, which are to be supplied in an assembly, are listed with a dot(.) in front of the part name as shown below.

EXAMPLE  
CARBURETOR ASSY

.JET, PILOT

.NOZZLE, MAIN

4. Number of component for assembly  
The numeral appearing to the right of each component part indicates the quantity of parts for each assembly unit.

EXAMPLE

PART NO.	DESCRIPTION	u	u	u	u	REMARKS
6E0-85500-70	C.D.I. MAGNETO ASSY	1				
6E0-85550-70	.ROTOR ASSY	1				
6E0-15723-00-94	.PULLY, STARTER	1				

5. Quantity Column Information

NAME for Q'TY COLUMN	APPLICABLE MODEL
F4A	F4AMH

6. Applicable Starting Serial No. and Color Code  
1) Engine Starting Sserial No.

F4AMH S/L 68D : 1000001

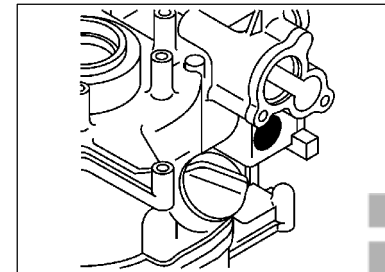
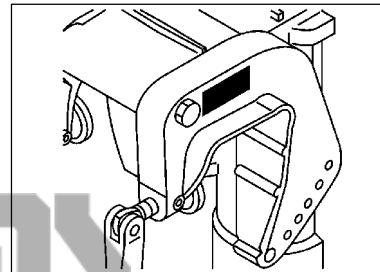

2) Color Code

Color Code	Color Name	Abbreviation
004D	DARK BLUISH GRAY METALLIC 2	DBNM2

7. Note that the illustrations for reference in finding parts numbers, not to be used for assembling. When assembling, please use the applicable service manual.

8. The asterisk (\*) before a reference number indicates modification items after the first edition.

# AVANT-PROPOS

Ce Catalogue de pièces détachées concerne les pièces pour le(s) modèle(s) indiqué(s) dans le cadre ci-dessous. Lorsque vous commandez des pièces de rechange, veuillez vous référer à ce catalogue de pièces détachées et indiquer clairement les numéros et les noms des pièces détachées.

F4AMH'03(68D3)

1. Les modifications ou ajouts ayant été effectués après la parution du catalogue de pièces détachées seront décrits dans les Bulletins d'information Yamaha concernant les pièces détachées. Il est recommandé que vous apportiez les corrections nécessaires au catalogue des pièces détachées en vous référant aux Bulletins d'information Yamaha.

2. Abréviations

Dans ce catalogue, les abréviations suivantes sont utilisées:

- "UR" Utiliser le numéro des pièces.
- "UN" Utiliser autant que nécessaire.
- "AP" Pièces de substitution
- "LM" Fabrication locale (les pièces doivent être commandées localement.)

3. Dans ce catalogue, les pièces qui sont fournies dans un ensemble sont précédées d'un point (.) de la manière indiquée ci-dessous.

EXEMPLE

- ENS CARBURATEUR
- .GICLEUR, ralenti
- .PUITS D'AIGUILLE

4. Nombre de pièces composant un ensemble

Le chiffre apparaissant à la droite de chaque description indique la quantité de pièces pour chaque ensemble de pièces.

EXEMPLE

NO. PIECES	DESCRIPTION	ω	⊕	⊖	REMARQUES
6E0-85500-70	MAGNETO C.D.I. CPLT	1			
6E0-85550-70	.ROTOR CPLT	1			
6E0-15723-00-94	..POULIE DE DEMARREUR	1			

5. Indication concernant la quantité

Indication concernant la quantité	Applications modèle
F4A	F4AMH

6. Applications No de série et code couleur correspondants

1) No. de série du moteur

F4AMH S/L 68D : 1000001

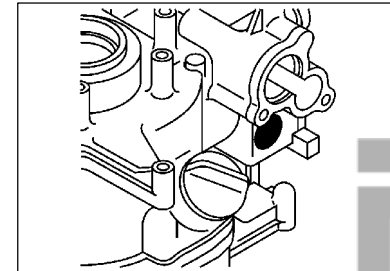
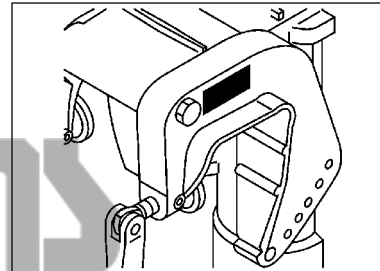

2) Code couleur

Code couleur	Nom de couleur	Abréviation
004D	DARK BLUISH GRAY METALLIC 2	DBNM2

7. Veuillez noter que les illustrations sont indiquées pour référence pour trouver les numéros de pièces, non pour être utilisées lors de l'assemblage. Lors de l'assemblage, veuillez utiliser le manuel d'entretien adéquat.

8. L'astérisque (\*) placé devant un numéro de référence. indique des éléments qui ont été modifiés après la première édition.



FLOOD MARINE SERVICES  
downloaded from www.yamahaoutboardparts.co.uk



FLOOD MARINE SERVICES  
downloaded from www.yamahaoutboardparts.co.uk



FLOOD MARINE SERVICES  
downloaded from www.yamahaoutboardparts.co.uk

# CONTENTS

TOP COWLING .....	A4
CYLINDER. CRANKCASE 1 .....	A5
CRANKSHAFT. PISTON .....	A6
CYLINDER. CRANKCASE 2 .....	A7
VALVE .....	B2
INTAKE .....	B3
CARBURETOR .....	B4
FUEL 1 .....	B5
FUEL 2 .....	B6
STARTER .....	C1
GENERATOR .....	C3
BOTTOM COWLING .....	C4
STEERING .....	C5
CONTROL .....	C7
BRACKET .....	D1
UPPER CASING .....	D3
LOWER CASING. DRIVE 1 .....	D4
LOWER CASING. DRIVE 2 .....	D6
REPAIR KIT 1 .....	D7
REPAIR KIT 2 .....	E1

## INDEX

NUMERICAL INDEX .....	E2
-----------------------	----



FLOOD MARINE SERVICES  
downloaded from www.yamahaoutboardparts.co.uk



FLOOD MARINE SERVICES  
downloaded from www.yamahaoutboardparts.co.uk



FLOOD MARINE SERVICES  
downloaded from www.yamahaoutboardparts.co.uk



FLOOD MARINE SERVICES  
downloaded from www.yamahaoutboardparts.co.uk



FLOOD MARINE SERVICES  
downloaded from www.yamahaoutboardparts.co.uk



FLOOD MARINE SERVICES  
downloaded from www.yamahaoutboardparts.co.uk

# TABLE DES MATIERES

CAPOT SUPERIEUR .....	A4
CYLINDRE. CARTER 1 .....	A5
VILEBREQUIN. PISTON .....	A6
CYLINDRE. CARTER 2 .....	A7
SOUPAPE .....	B2
ADMISSION .....	B3
CARBURATEUR .....	B4
CARBURANT 1 .....	B5
CARBURANT 2 .....	B6
DEMARREUR .....	C1
GENERATRICE .....	C3
CAPOT INFERIEUR .....	C4
DIRECTION .....	C5
COMMANDE .....	C7
SUPPORT .....	D1
FOURREAU .....	D3
BOITIER D'HELICE, TRANSMISSION 1 .....	D4
BOITIER D'HELICE, TRANSMISSION 2 .....	D6
KITS DE REPARATION 1 .....	D7
KITS DE REPARATION 2 .....	E1

## INDEX

INDEX NUMERIQUE .....	E2
-----------------------	----

**FIG. 1 TOP COWLING**

**CAPOT SUPERIEUR**

REF. NO.	PART NO. NO. PIECES	DESCRIPTION DESCRIPTION	F4A	REMARKS REMARQUES
1	68D-G2610-40-4D	TOP COWLING ASSY CAPOT (ENS.)	1	
2	68D-G2613-01	.MOLDING, AIR DUCT .MANCHON A AIR	1	
3	97780-40012	.SCREW, TAPPING .VIS, TETE BOMBEE	3	
4	68D-WG070-00	.GRAPHIC SET .JEU DIEMBLEMES	1	
5	68D-G2677-00	.GRAPHIC, FRONT .ADHESIF, AVANT	1	
6	68D-G2678-00	.GRAPHIC, REAR .ADHESIF, ARRIERE	1	
7	68D-42662-00	.DAMPER .AMORTISSEUR	2	
8	67F-13434-02	LABEL, CAUTION ETIQUETTE, ATTENTION	1	

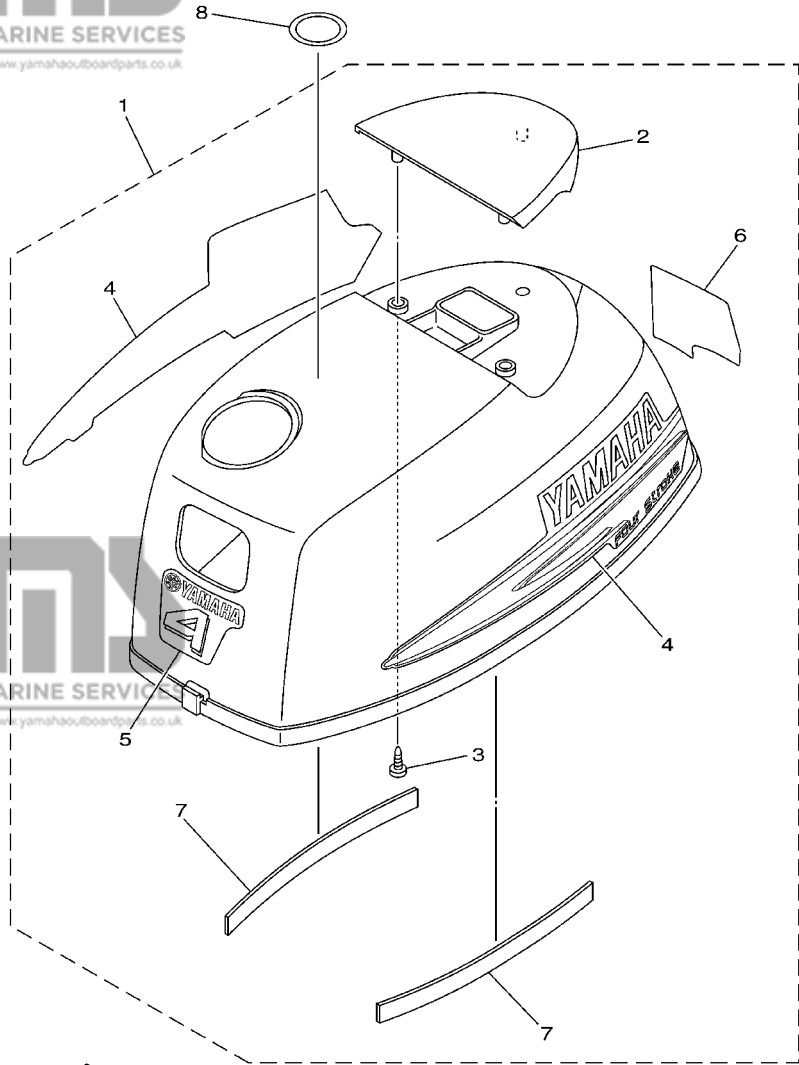

**FWD**  
68D2010-2010

**CRANK CYLINDER ASSY**  
(Fig. 2, Ref. No. 2 to 21  
Fig. 3, Ref. No. 1 to 8  
Fig. 4, Ref. No. 1 to 3, 5 to 29  
Fig. 5, Ref. No. 1 to 15  
Fig. 6, Ref. No. 12  
Fig. 16, Ref. No. 2)

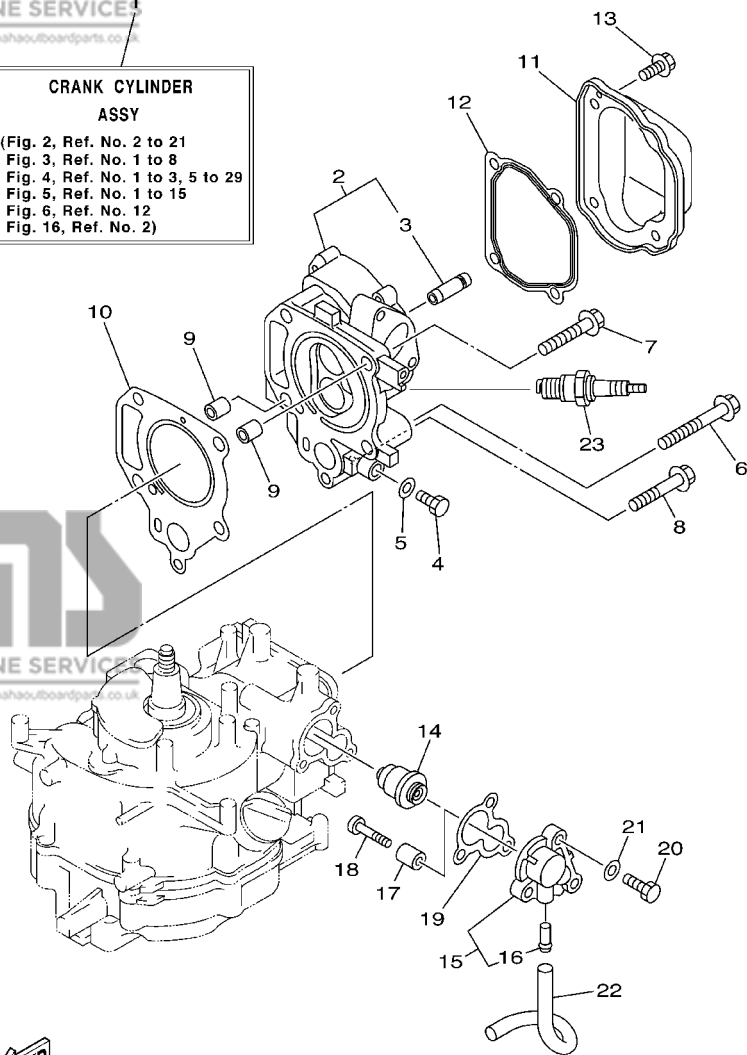

68D3100-3020

**FIG. 2 CYLINDER. CRANKCASE 1 CYLINDRE. CARTER 1**

REF. NO.	PART NO. NO. PIECES	DESCRIPTION DESCRIPTION	F4A	REMARKS REMARQUES
1	68D-WE090-10-4D	CRANK CYLINDER ASSY EMBIELLAGE CYLINDRE (ENS.)	1	
2	68D-E1111-10-94	HEAD, CYLINDER 1 CULASSE	1	
3	67D-11133-10	.GUIDE, INTAKE VALVE .GUIDE, SOUP D'ADM	2	
4	97095-08014	BOLT BOULON	1	
5	90430-08800	GASKET JOINT	1	
6	90105-08M36	BOLT, FLANGE BOULON	3	
7	90105-08046	BOLT, FLANGE BOULON	1	
8	90105-06M25	BOLT, FLANGE BOULON	1	
9	99510-10114	PIN, DOWEL GOUJON, D'ASSEMBLAGE	2	
10	67D-11181-A0	GASKET, CYLINDER HEAD 1 JOINT, DE CULASSE 1	1	
11	67D-11191-00	COVER, CYLINDER HEAD 1 COUVERCLE, CULASSE 1	1	
12	68D-E1193-A0	GASKET, HEAD COVER 1 JOINT, COUVERCLE DE CULASSE 1	1	
13	90105-06M14	BOLT FLANGE BOULON	4	
14	66M-12411-00	THERMOSTAT THERMOSTAT	1	
15	68D-E2413-00-9M	COVER, THERMOSTAT COUVERCLE, THERMOSTAT	1	
16	650-24378-00	.PIPE, JOINT 4 .DURITE RACCORDEMENT 4	1	
17	68D-E1325-00	ANODE ANODE	1	
18	97880-05025	SCREW, PAN HEAD VIS, TETE TRONCONIQUE	1	
19	68D-E2414-A0	GASKET, COVER JOINT, COUVERCLE	1	
20	97095-06020	BOLT BOULON	3	
21	92995-06600	WASHER RONDELLE	3	
22	90445-09807	HOSE (L180) DURITE (L180)	1	
23	94702-00248	PLUG, SPARK (NGK BR6HS) BOUGIE D,ALLUMAGE (NGK BR6HS)	1	

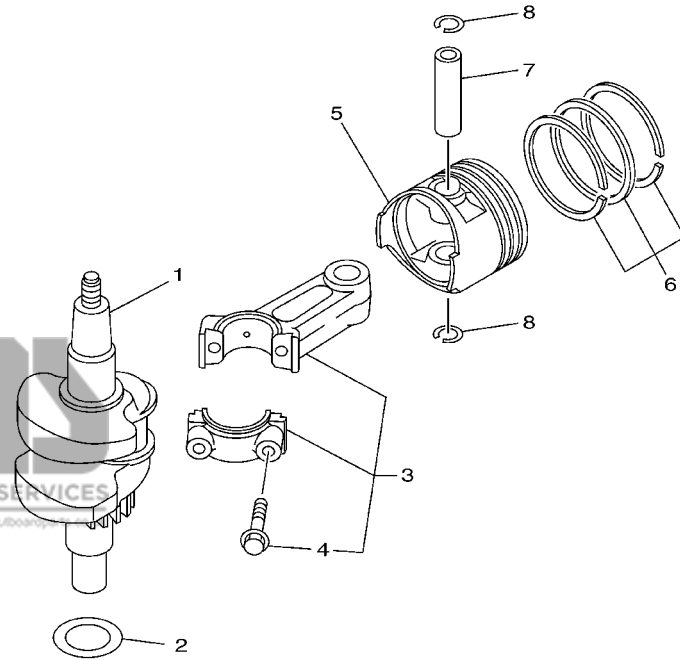

**FWD**  
67D0010-8030

**FIG. 3 CRANKSHAFT. PISTON**

REF. NO.	PART NO. NO. PIECES	DESCRIPTION DESCRIPTION
1	67D-11400-00	CRANKSHAFT ASSY VILEBREQUIN COMPLET
2	90201-266P2	WASHER, PLATE RONDELLE, PLATE
3	67D-11650-00	CONNECTING ROD ASSY BIELLE COMPLETE
4	67D-11654-00	.BOLT, CONNECTING ROD .BOULON, BIELLE
5	68D-E1631-00-96	PISTON (STD) PISTON (STD)
68D-E1635-00	PISTON (0.25MM O/S) PISTON (0.25MM O/S)	
68D-E1636-00	PISTON (0.50MM O/S) PISTON (0.50MM O/S)	
6	68D-E1603-00	PISTON RING SET (STD) JEU DE SEGMENTS (STD)
68D-E1604-00	PISTON RING SET (0.25MM O/S) JUE DE SEGMENTS (0.25MM O/S)	
68D-E1605-00	PISTON RING SET (0.50MM O/S) JEU DE SEGMENTS (0.50MM O/S)	
7	68D-E1633-00	PIN, PISTON AXE, PISTON
8	93450-14088	CIRCLIP CIRCLIP

**VILEBREQUIN. PISTON**

F4A	REMARKS REMARQUES
1	
1	
1	
2	
1	
1	AP
1	AP
1	AP
1	AP
1	AP
1	
2	



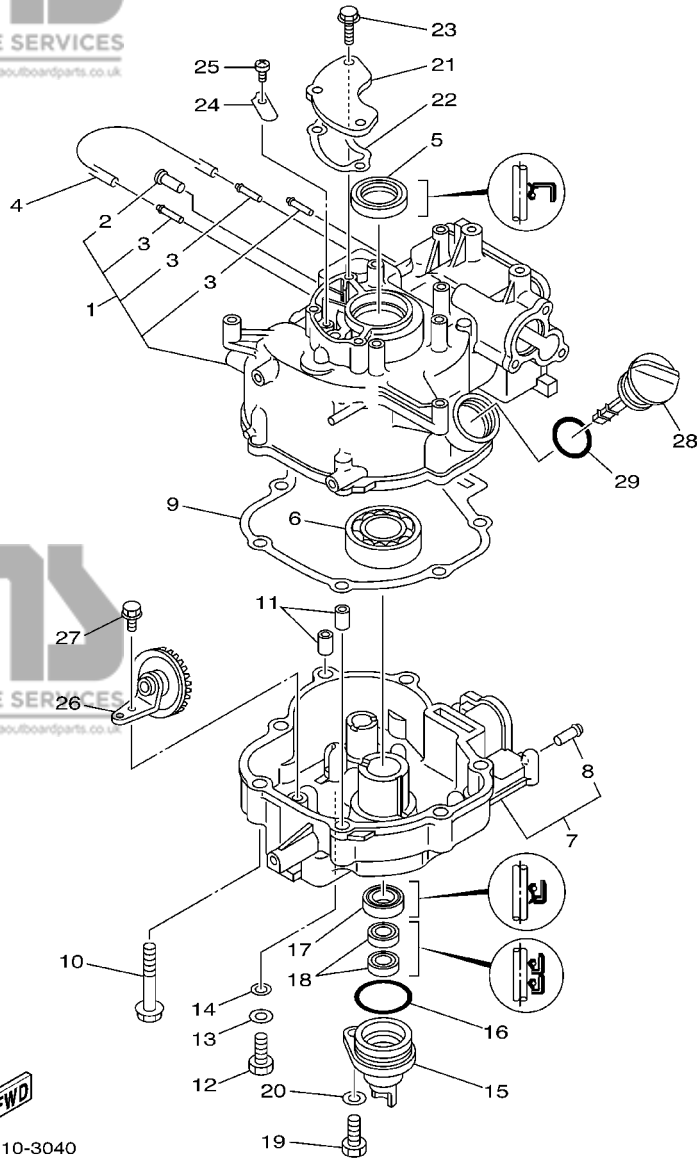

**FIG. 4 CYLINDER. CRANKCASE 2 CYLINDRE. CARTER 2**

REF. NO.	PART NO. NO. PIECES	DESCRIPTION DESCRIPTION	F4A	REMARKS REMARQUES
1	68D-E1311-01-94	CYLINDER 1 CYLINDRE 1	1	
2	650-24378-00	.PIPE, JOINT 4 .DURITE RACCORDEMENT 4	1	
3	6H1-14485-00	.PIPE, JOINT .DURITE	3	
4	90445-07806	HOSE (L167) DURITE (L167)	1	
5	93102-25090	OIL SEAL JOINT SPY	1	
6	93306-205YD	BEARING ROULEMENT	1	
7	68D-E5111-00-94	CRANKCASE 1 CARTER DE MOTEUR	1	
8	650-24378-00	.PIPE, JOINT 4 .DURITE RACCORDEMENT 4	1	
9	68D-11351-A0	GASKET, CYLINDER JOINT, D'EMBASE	1	
10	97575-08550	BOLT, WITH WASHER VIS HEXAGONAL AVC RONDELLE	7	
11	99510-10114	PIN, DOWEL GOUJON, D'ASSEMBLAGE	2	
12	97095-08020	BOLT BOULON	1	
13	92995-08600	WASHER RONDELLE	1	
14	90201-08818	WASHER, PLATE RONDELLE, PLATE	1	
15	68D-E5396-00-5B	HOUSING, OIL SEAL LOGEMENT DE JOINT SPY	1	
16	93210-35537	O-RING JOINT TORIQUE	1	
17	93102-20108	OIL SEAL JOINT SPY	1	
18	93102-10004	OIL SEAL JOINT SPY	2	
19	97095-08020	BOLT BOULON	1	
20	92995-08600	WASHER RONDELLE	1	
21	68D-E1168-00	COVER, BREATHER COUVERCLE, RENIFLARD	1	
22	68D-E1169-A0	GASKET, BREATHER COVER JOINT, COUVERCLE DE RENIFLARD	1	
23	90119-06M80	BOLT, WITH WASHER BOULON, AVEC RONDELLE	3	
24	68D-E5346-00	BREATHER 1 RENIFLARD 1	1	
25	98503-04006	SCREW, PAN HEAD VIS	1	
26	68D-E3102-00	GEAR UNIT ASSY PIGNON	1	
27	95817-06012	BOLT, FLANGE BOULON, A COLLERETTE	1	

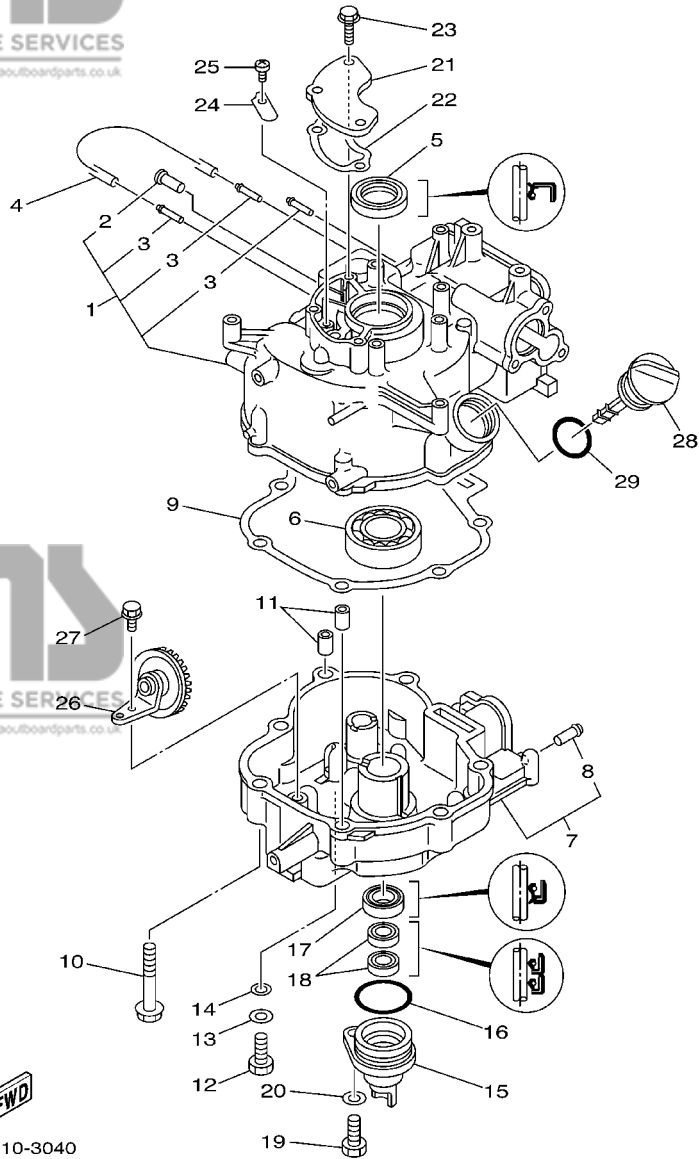

**FIG. 4 CYLINDER. CRANKCASE 2      CYLINDRE. CARTER 2**

REF. NO.	PART NO. NO. PIECES	DESCRIPTION DESCRIPTION	F4A	REMARKS REMARQUES
28	68D-E5362-00	PLUG, OIL LEVEL PLOT, NIVEAU D'HUILE	1	
29	93210-24M79	O-RING JOINT TORIQUE	1	

**B1**

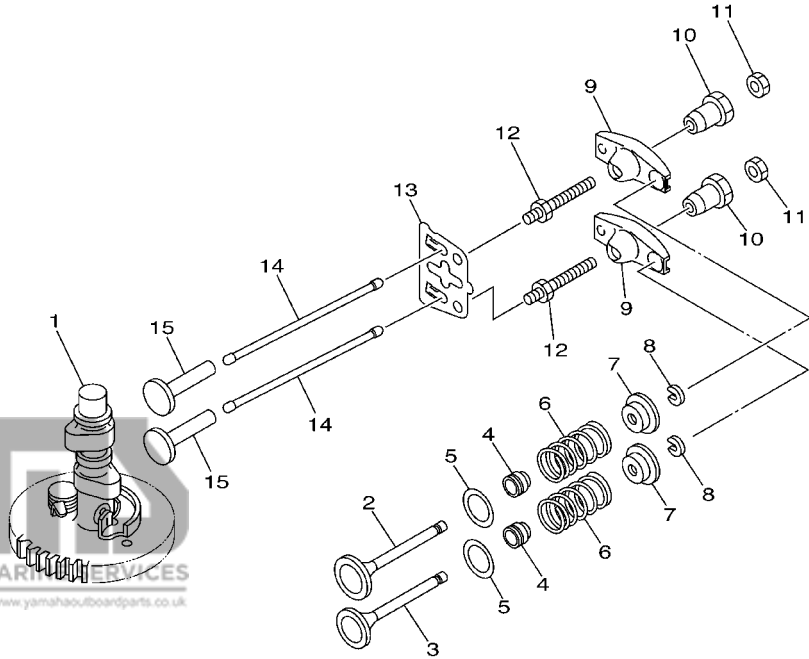

**FIG. 5 VALVE**

**SOUPAPE**

REF. NO.	PART NO. NO. PIECES	DESCRIPTION DESCRIPTION	F4A	REMARKS REMARQUES
1	68D-E2170-00	CAMSHAFT ASSY 1 ENS ARBRE A CAMES 1	1	
2	67D-12111-00	VALVE, INTAKE SOUPAPE, ADMISSION	1	
3	67D-12121-00	VALVE, EXHAUST SOUPAPE, ECHAPPEMENT	1	
4	51Y-12119-00	SEAL, VALVE STEM JOINT, QUEUE DE SOUPAPE	2	
5	68T-12116-00	SEAT, VALVE SPRING SIEGE, RESSORT DE SOUPAPE	2	
6	68D-E2113-00	SPRING, VALVE INNER RESSORT DE SOUPAPE, INTERNE	2	
7	7NJ-12117-00	RETAINER, VALVE SPRING BUTEE DE RESSORT DE SOUPAPE	2	
8	7NJ-12118-00	COTTER, VALVE FRAISE, SOUPAPE	2	
9	67D-12151-00	ARM, VALVE ROCKER CULBUTEUR	2	
10	7FK-12165-00	PIVOT, ROCKER ARM PIVOT, CULBUTEUR	2	
11	7FK-12158-00	NUT, LOCK CONTRE-ECROU	2	
12	67D-12157-00	BOLT BOULON	2	
13	68D-E2155-00	GUIDE, PUSH ROD GUIDE, TIGE-POUSSOIR	1	
14	67D-12154-00	ROD, VALVE PUSH TIGE DE LEVE-SOUPAPE	2	
15	JA9-12153-00	LIFTER, VALVE LEVE-SOUPAPE	2	



68D3010-3050

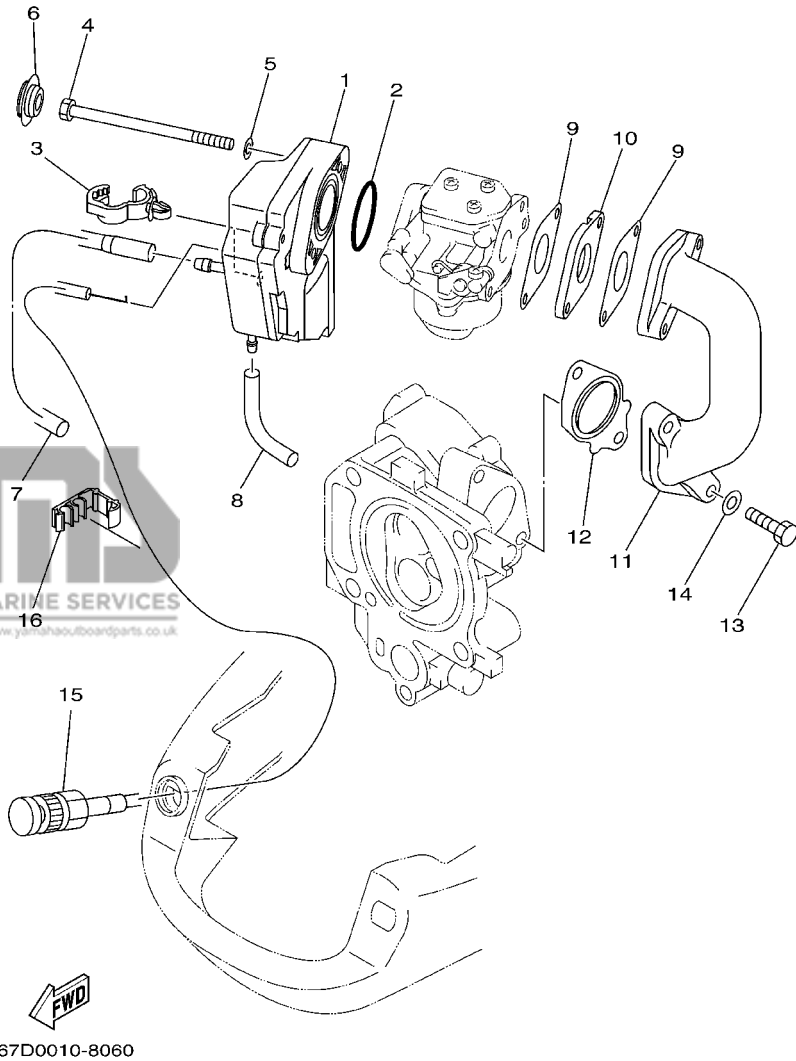
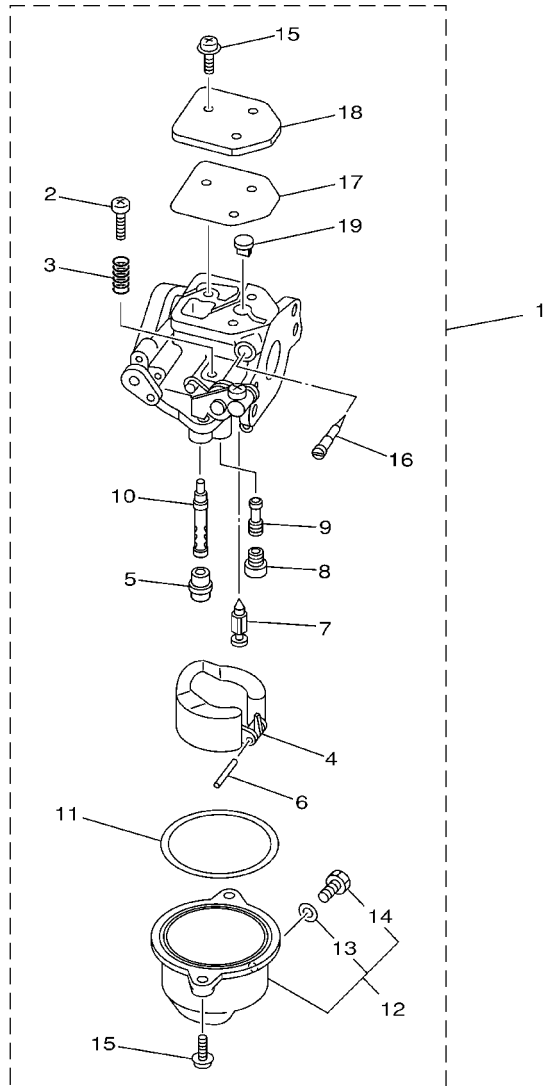

**FIG. 6 INTAKE**

REF. NO.	PART NO. NO. PIECES	DESCRIPTION DESCRIPTION
1	68D-E4440-00	SILENCER ASSY, INTAKE SIENCIEUX D'ADMISSION
2	93210-31MJ5	O-RING JOINT TORIQUE
3	90464-13249	CLAMP BRIDE
4	97095-06090	BOLT BOULON
5	92995-06600	WASHER RONDELLE
6	90480-18M74	GROMMET PASSE-FIL
7	68D-F4314-00	PIPE 4 DURITE 4
8	90445-07805	HOSE (L70) DURITE (L70)
9	68D-E3646-A0	GASKET, MANIFOLD 2 JOINT, TUBULURE 2
10	68D-E3647-00	GASKET, MANIFOLD 3 JOINT, TUBULURE 3
11	68D-E3641-00-94	MANIFOLD 1 TUBULURE 1
12	68D-E3645-A0	GASKET, MANIFOLD 1 JOINT, TUBULURE 1
13	97095-06025	BOLT BOULON
14	92995-06600	WASHER RONDELLE
15	68D-F6330-00	STARTER CABLE ASSY CABLE DE STARTER
16	90464-05122	CLAMP BRIDE

**ADMISSION**

F4A	REMARKS REMARQUES
1	
1	
1	
2	
2	
2	
1	
1	
1	
2	
2	
1	
1	
1	



67D0010-8070

**FIG. 7 CARBURETOR**

**CARBURATEUR**

REF. NO.	PART NO. NO. PIECES	DESCRIPTION DESCRIPTION	F4A	REMARKS REMARQUES
1	67D-14301-01	CARBURETOR ASSY 1 CARBURATEUR COMPLET 1	1	FOR STD
	67D-14301-20	CARBURETOR ASSY 1 CARBURATEUR COMPLET 1	1	FOR SAV
2	6E5-14321-00	.SCREW, THROTTLE .VIS, ACCELERATEUR	1	
3	6J8-14334-00	.SPRING, THROTTLE .RESSORT, ACCELERATEUR	1	
4	68T-14385-00	.FLOAT .FLOTTEUR	1	
5	67D-14966-00	.RUBBER CAP .CAOUTCHOUC CASQUILLO	1	
6	67D-14386-00	.PIN, FLOAT .AXE, FLOTTEUR	1	
7	67D-14546-00	.VALVE, NEEDLE .POINTEAU	1	
8	67D-1492E-34	.JET, MAIN (#68) .GICLEUR, PRINCIPAL (#68)	1	
9	67D-1492F-18	.JET, AIR SLOW (#36) .GICLEUR, AIR (#36)	1	
10	67D-1492A-00	.NOZZLE, MAIN .PUIITS D'AIGUILLE	1	
11	67D-14984-00	.GASKET, FLOAT CHAMBER .JOINT, CUVE DE FLOTTEUR	1	
12	67D-14981-00	.BODY, FLOAT CHAMBER .CORPS, CUVE DE FLOTTEUR	1	
13	6J8-14959-00	.GASKET .JOINT	1	
14	66T-14991-00	.PLUG, DRAIN .BOUCHON DE VIDANGE	1	
15	97980-04112	.SCREW, WITH WASHER .VIS, AVEC RONDELLE	5	
16	67D-14323-00	.SCREW, AIR ADJUSTING .VIS DE DOSEUR D'AIR	1	FOR 67D-14301-01
	68T-14323-20	.SCREW, AIR ADJUSTING .VIS DE DOSEUR D'AIR	1	FOR 67D-14301-20
17	67D-14536-00	.GASKET .JOINT	1	
18	67D-14527-00	.PLATE .PLAQUE	1	
19	67D-14126-00	.PLUG .PLOT	1	

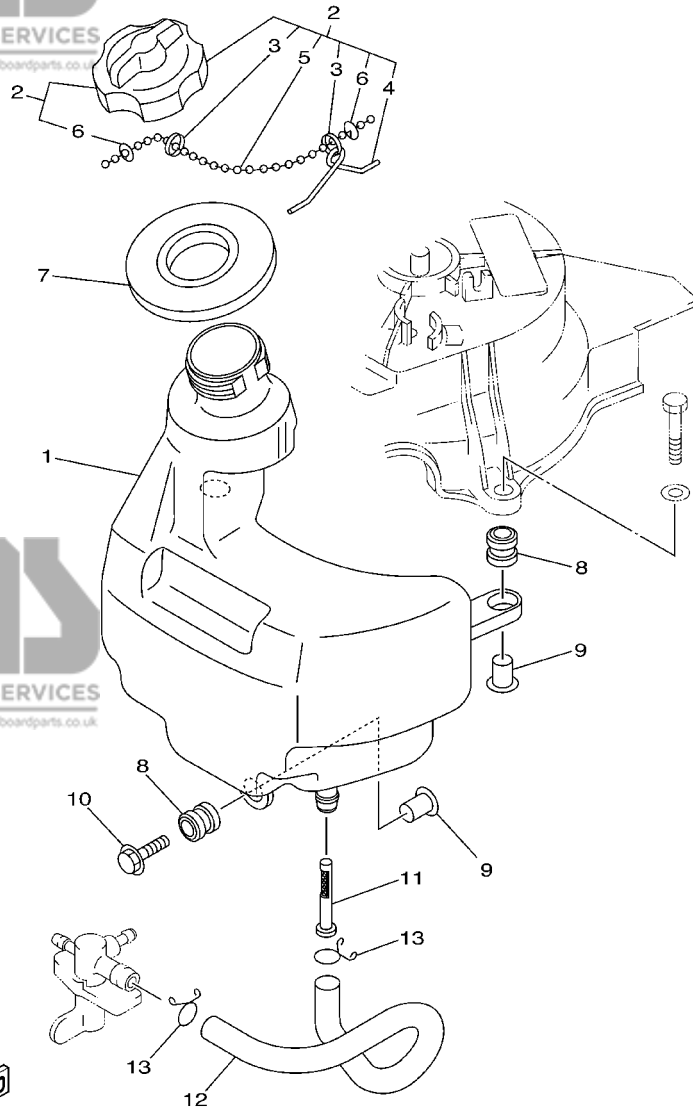

68D3010-3080

FIG. 8 FUEL 1

CARBURANT 1

REF. NO.	PART NO. NO. PIECES	DESCRIPTION DESCRIPTION	F4A	REMARKS REMARQUES
1	68D-F4111-00	TANK, FUEL RESERVOIR, A ESSENCE	1	
2	67D-24610-02	CAP ASSY BOUCHON	1	
3	90501-10260	.SPRING, COMPRESSION .RESSORT, COMPRESSION	2	
4	624-24634-00	.HOOK, CHAIN BALL .ATTACHE	1	
5	69M-24633-00	.CHAIN, BALL .CHANE DE BALLE	1	
6	6H1-21757-00	.WASHER, SPECIAL 1 .RONDELLE, SPECIALE 1	2	
7	6L5-24641-00	GASKET, CAP 1 JOINT 1, BOUCHON	1	
8	6A0-82317-00	DAMPER, IGNITION COIL AMORTISSEUR, BOBINE D'ALLUM	3	
9	624-42542-00	PIPE TUYAU	3	
10	90119-06M88	BOLT, WITH WASHER BOULON, AVEC RONDELLE	1	
11	6L5-24251-00	STRAINER 1 FILTRE 1	1	
12	68D-F4311-00	PIPE, FUEL 1 DURITE A ESSENCE	1	
13	90467-13M13	CLIP JONC	2	

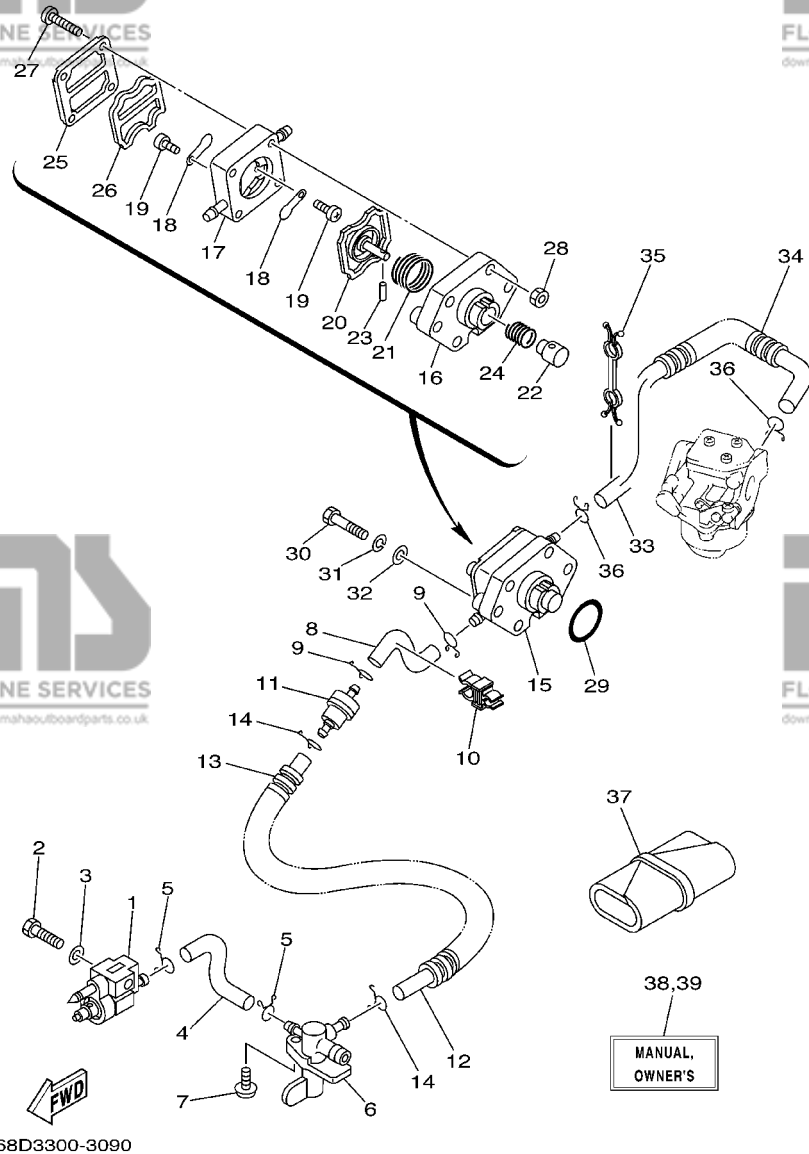
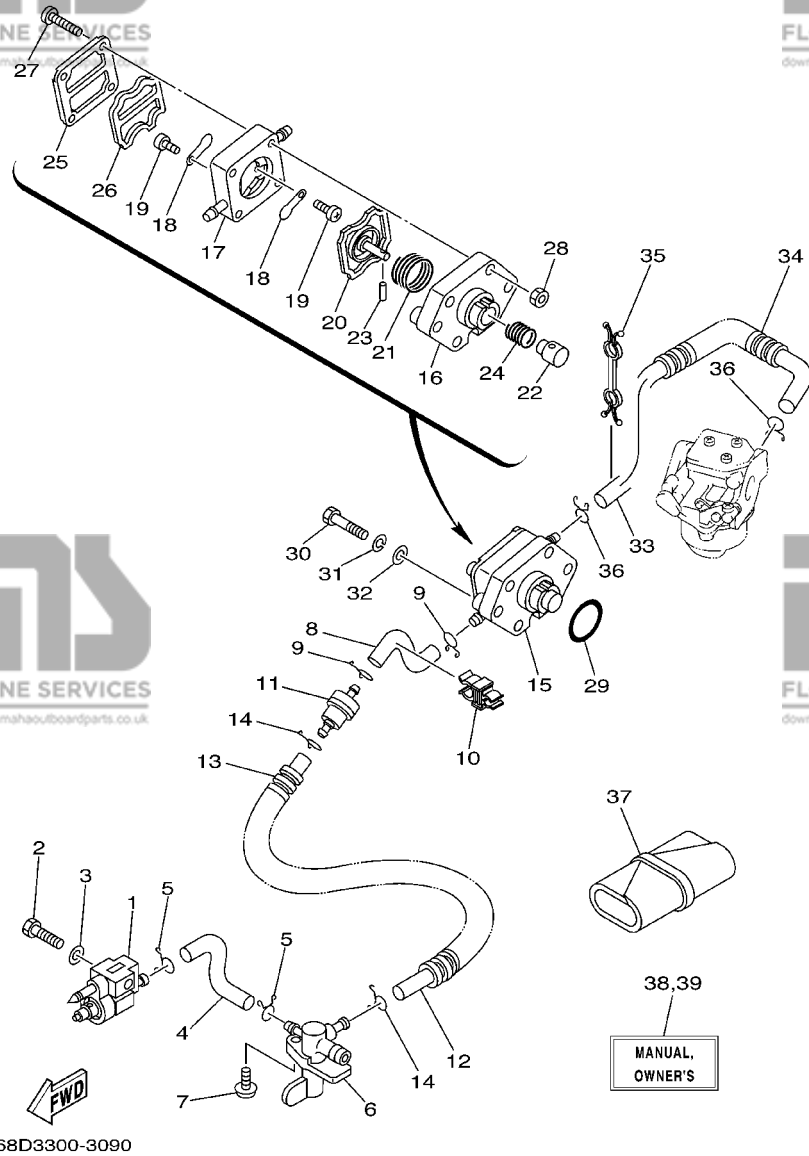

**FIG. 9 FUEL 2**

**CARBURANT 2**

REF. NO.	PART NO. NO. PIECES	DESCRIPTION DESCRIPTION	F4A	REMARKS REMARQUES
1	6G1-24304-02	FUEL PIPE JOINT COMP. 1 DURITE RACCORDEMT. A ESSENCE	1	
2	97095-06025	BOLT BOULON	1	
3	92995-06600	WASHER RONDELLE	1	
4	68D-F4312-00	PIPE 2 DURITE 2	1	
5	90467-09M09	CLIP JONC	2	
6	68D-F4500-00	FUEL COCK ASSY 1 ROBINET A ESSENCE	1	
7	90159-06M10	SCREW, WITH WASHER VIS, AVEC RONDELLE	1	
8	68D-F4313-00	PIPE 3 DURITE 3	1	
9	90467-09M09	CLIP JONC	2	
10	90464-10M52	CLAMP BRIDE	1	
11	646-24251-02	STRAINER 1 FILTRE 1	1	
12	90445-10804	HOSE (L140) DURITE (L140)	1	
13	90446-14M12	HOSE DURITE	1	
14	90467-09M09	CLIP JONC	2	
15	67D-24410-02	FUEL PUMP ASSY POMPE A ESSENCE	1	
16	67D-24412-00	.BODY 1 .CORPS 1	1	
17	67D-24413-02	.BODY 2 .CORPS 2	1	
18	6A0-24421-01	.VALVE, CHECK SOUPAPE, RETENUE	2	
19	6E7-14325-00	.SCREW, PAN HEAD VIS TETE CONIQUE	2	
20	67D-24411-00	.DIAPHRAGM .DIAPHRAGME	1	
21	67D-24423-00	.SPRING, DIAPHRAGM .RESSORT, DIAPHRAGME	1	
22	67D-13131-00	.PLUNGER .PLONGEUR	1	
23	66M-24374-00	.PIN .GOUPILLE	1	
24	67D-24454-00	.SPRING .RESSORT	1	
25	67D-24414-01	.BODY 3 .CORPS 3	1	
26	66M-24471-00	.DIAPHRAGM .DIAPHRAGME	1	
27	67D-24444-00	.SCREW .VIS	4	

**B6**

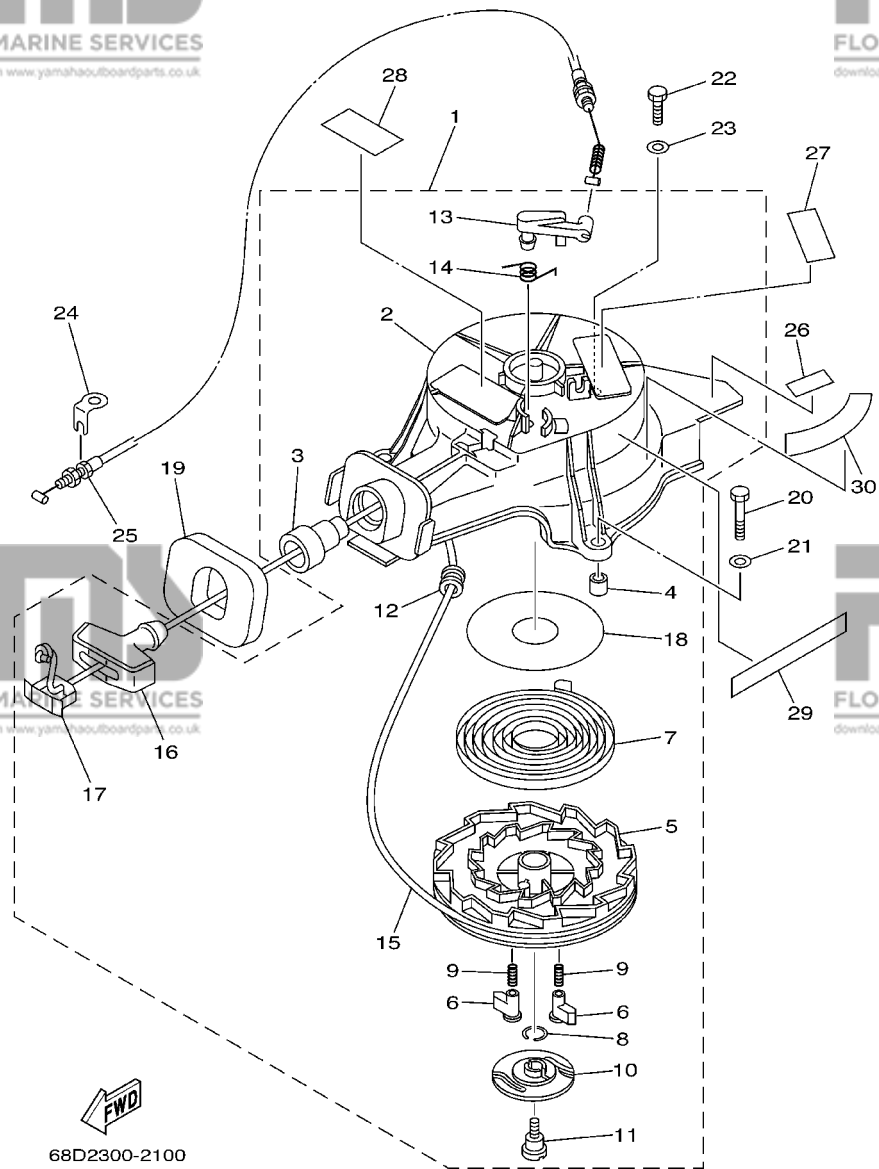

**FIG. 9 FUEL 2**

**CARBURANT 2**

REF. NO.	PART NO. NO. PIECES	DESCRIPTION DESCRIPTION	F4A	REMARKS REMARQUES
28	95380-04600	.NUT .ECROU	4	
29	93210-27ME3	O-RING JOINT TORIQUE	1	
30	97095-06030	BOLT BOULON	2	
31	92995-06100	WASHER, SPRING RONDELLE, GROWER	2	
32	92995-06600	WASHER RONDELLE	2	
33	90445-10805	HOSE (L250) DURITE (L250)	1	
34	90446-14M12	HOSE DURITE	1	
35	90464-10M53	CLAMP BRIDE	1	
36	90467-09M09	CLIP JONC	2	
37	68D-F8100-00	TOOL KIT TROUSSE A OUTILS	1	
38	68D-F8199-72-A0	MANUAL, OWNER'S MANUEL D'UTILISATION	1	UR (E,F,S)
	68D-F8199-72-B0	MANUAL, OWNER'S MANUEL D'UTILISATION	1	UR (D,NL,I)
39	68D-F8199-82-A0	MANUAL, OWNER'S MANUEL D'UTILISATION	1	UR (DK,P,GR)
	68D-F8199-82-B0	MANUAL, OWNER'S MANUEL D'UTILISATION	1	UR (N,S,SS)





**FIG. 10 STARTER**

**DEMARREUR**

REF. NO.	PART NO. NO. PIECES	DESCRIPTION DESCRIPTION	F4A	REMARKS REMARQUES
1	67D-15710-00	STARTER ASSY DEMARREUR COMPLET	1	
2	67D-15711-00	.CASE, STARTER .CARTER DE DEMARREUR	1	
3	63V-15795-01	.GUIDE, ROPE GUIDE DE CABLE	1	
4	67D-15764-00	.COLLAR 1 .COLLERETTE 1	3	
5	67D-15714-00	.DRUM, SHEAVE .TAMBOUR, POULIE	1	
6	67D-15741-00	.PAWL, DRIVE .CLIQUET, ENTRAINEMENT	2	
7	67D-15713-00	.SPRING, STARTER .RESSORT DE DEMARREUR	1	
8	67D-15705-00	.SPRING, DRIVE PAWL .RESSORT DE CLIQUET	1	
9	67D-15767-00	.SPRING .RESSORT	2	
10	67D-15735-00	.GUIDE, CAM .COULISSEAU	1	
11	67D-15793-00	.SCREW .VIS	1	
12	63V-15764-00	.COLLAR 1 .COLLERETTE 1	1	
13	67D-15794-00	.STOPPER .BUTEE	1	
14	67D-15734-00	.SPRING, RETURN .RESSORT, RAPPEL	1	
15	*	.WIRE, STARTER (L:1800MM) CABLE DE DEMARREUR (L:1800MM)	1	
16	6G1-15755-00	.HANDLE, STARTER .POIGNEE, DE DEMARREUR	1	
17	6G1-15779-00	.COVER .COUVERCLE	1	
18	67D-15739-00	.WASHER, THRUST .RONDELLE, DE BUTEE	1	
19	67D-15762-00	SEAL, RUBBER 2 JOINT CAOUTCHOUC 2	1	
20	97095-06035	BOLT BOULON	2	
21	92995-06600	WASHER RONDELLE	2	
22	97095-06020	BOLT BOULON	1	
23	92995-06600	WASHER RONDELLE	1	
24	67D-15772-00	STAY 2 SUPPORT 2	1	
25	67D-15770-00	CABLE COMP., STARTER STOP CABLE, BUTEE DE DEMAR	1	

\* CUT FROM 50M ROLLS, PART NO. 90890-44372,  
CUTTING LENGTH 1.8M

\* A PRELEVER SUR BOBINE 50M , REFERENCE 90890-44372,  
LONGUEUR DE COUPE 1.8M

**C1**

**FIG. 10 STARTER**

**DEMARREUR**

REF. NO.	PART NO. NO. PIECES	DESCRIPTION DESCRIPTION	F4A	REMARKS REMARQUES
26	67D-42791-10	MARK 1 ETIQUETTE 1	1	
27	6A1-83625-41	MARK 5 ETIQUETTE 5	1	
28	6A1-83625-51	MARK 5 ETIQUETTE 5	1	
29	68D-13437-60	MARK, CAUTION MAKER	1	
30	67D-14427-60	LABEL, INSTRUCTION ETIQUETTE, INSTRUCTION	1	

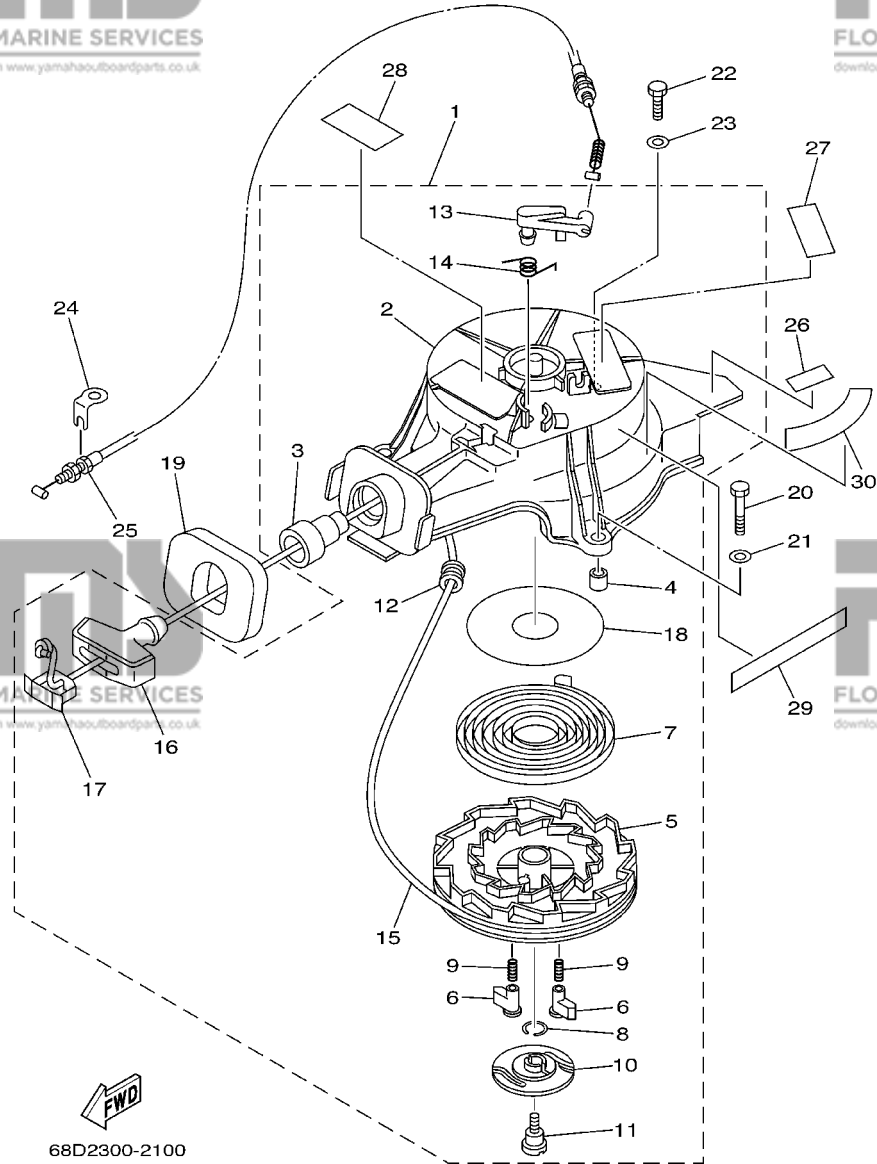

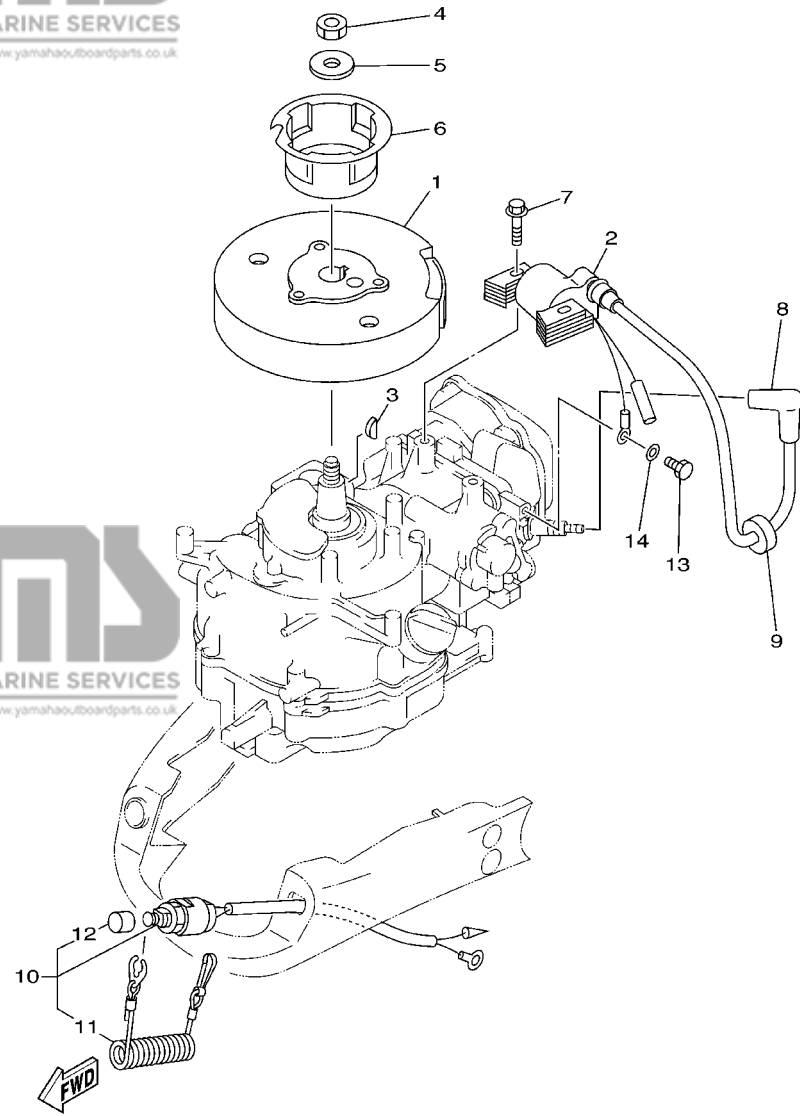

67D0300-8110

**FIG. 11 GENERATOR**

**GENERATRICE**

REF. NO.	PART NO. NO. PIECES	DESCRIPTION DESCRIPTION	F4A	REMARKS REMARQUES
1	67D-85650-00	ROTOR ASSY ROTOR COMPLET	1	
2	67D-85640-00	T.C.I. UNIT ASSY ENS. BLOC T.C.I.	1	
3	90280-04M06	KEY, WOODRUFF CLAVETTE, DEMI-LUNE	1	
4	90170-10M33	NUT ECROU	1	
5	90201-105A2	WASHER, PLATE RONDELLE, PLATE	1	
6	67D-15723-00	PULLEY, STARTER POULIE DE DEMARREUR	1	
7	90105-06M24	BOLT, FLANGE BOULON	2	
8	6E3-82370-21	PLUG CAP ASSY ANTIPARASITE	1	
9	90480-25161	GROMMET PASSE-FIL	1	
10	67D-82575-00	ENGINE STOP SWITCH ASSY COUPE CIRCUIT CPLT.	1	
11	682-82556-00	.STOPPER .PLAQUETTE	1	
12	689-8257Y-00	.CAP .CHAPEAU	1	
13	97095-06012	BOLT BOULON	1	
14	92995-06600	WASHER RONDELLE	1	

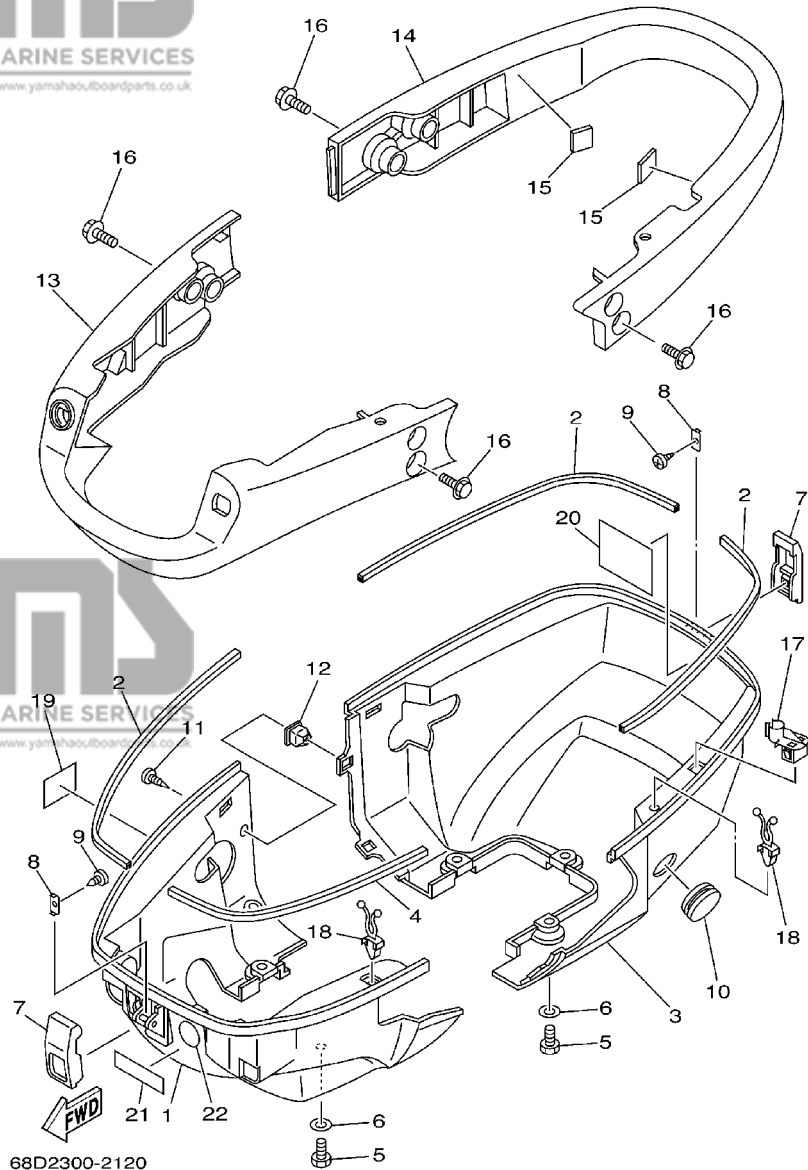

**FIG. 12 BOTTOM COWLING**

**CAPOT INFERIEUR**

REF. NO.	PART NO. NO. PIECES	DESCRIPTION DESCRIPTION	F4A	REMARKS REMARQUES
1	68D-G2711-01	COWLING, BOTTOM CUVETTE	1	
2	68D-G2628-00	SEAL JOINT	3	
3	68D-G2712-01	COWLING, BOTTOM CUVETTE	1	
4	68D-G2629-00	SEAL JOINT	1	
5	97095-06016	BOLT BOULON	6	
6	92995-06600	WASHER RONDELLE	6	
7	6L5-42647-00	HOLDER, CLAMP BAND SUPPORT, SANDOW DE SERRAGE	2	
8	6L5-42823-00	PLATE, STOP PLAQUE	2	
9	90167-03M02	SCREW, TAPPING VIS, TETE FRAISEE	2	
10	90480-22M72	GROMMET PASSE-FIL	1	
11	90161-05001	SCREW, TAPPING VIS, TETE FRAISEE	3	
12	90480-10004	GROMMET PASSE-FIL	3	
13	68D-G2731-00	CARRYING HANDLE POIGNEE DE PORTAGE	1	
14	68D-G2735-00	PROTECTOR PROTECTEUR	1	
15	67D-42662-00	DAMPER AMORTISSEUR	2	
16	90119-06M79	BOLT, WITH WASHER BOULON, AVEC RONDELLE	8	
17	90464-07M50	CLAMP BRIDE	1	
18	90464-07078	CLAMP BRIDE	2	
19	67D-13444-50	MARK MAKER	1	
20	68D-E2138-60	MARK, CAUTION MAKER	1	
21	68D-H257H-00	PLATE, MARK PLAQUE, ADHESIF	1	
22	6G8-2415E-00	LABEL, CAUTION EMBLEME, RECOMMANDATION	1	FOR SAV

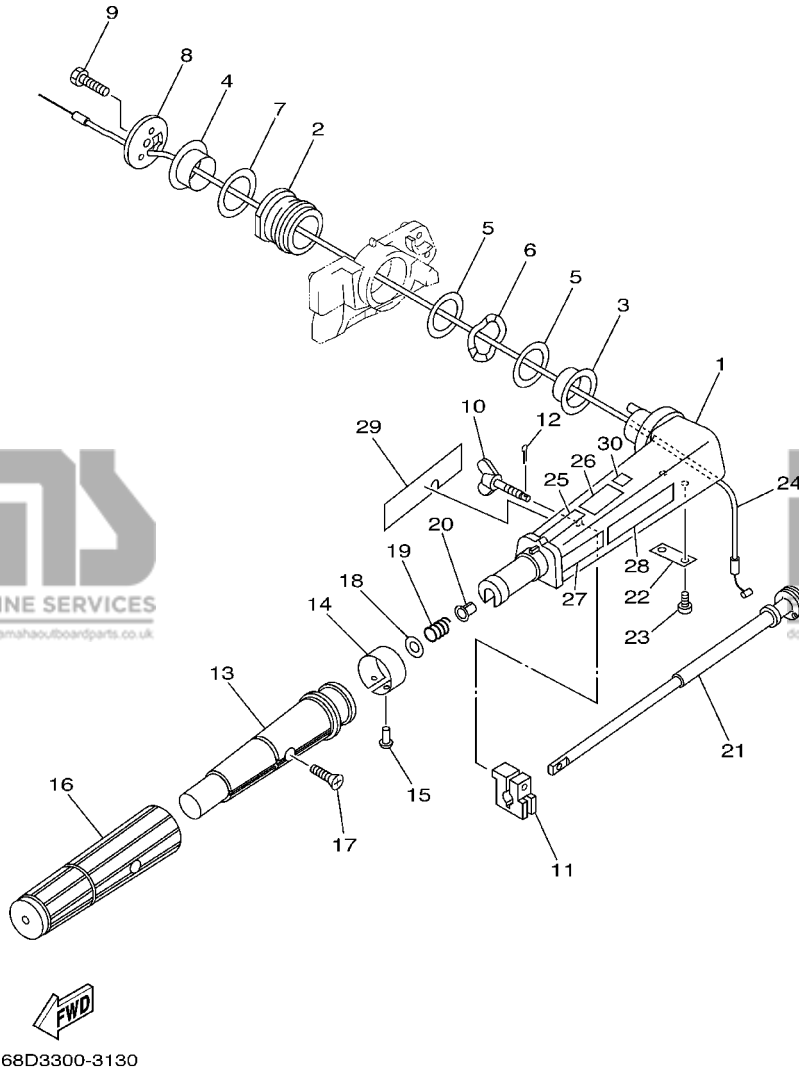

**FIG. 13 STEERING**

REF. NO.	PART NO. NO. PIECES	DESCRIPTION DESCRIPTION	DIRECTION	F4A	REMARKS REMARQUES
1	68D-G2111-00-4D	HANDLE, STEERING POIGNEE		1	
2	67D-42129-00	BUSHING, RUBBER DOUILLE, CAOUTCHOUC		1	
3	68D-G2171-00	BUSHING COUSSINET		1	
4	68D-G2172-00	BUSHING 2 DOUILLE 2		1	
5	68D-G2181-00	WASHER RONDELLE		2	
6	69M-G2188-00	WASHER, WAVE RONDELLE, ONDULEE		1	
7	68D-G2182-00	WASHER 2 RONDELLE 2		1	
8	68D-G2131-01	COVER, HANDLE STEERING COUVERCLE		1	
9	97075-08025	BOLT BOULON		1	
10	6G1-42125-01	BOLT, FRICTION ADJUSTING BOULON		1	
11	6N0-G2126-00	FRICTION, STEERING HANDLE GRIP CUVETTE, POIGNEE DE DIRECTION		1	
12	91490-16010	PIN, COTTER GOUPILLE		1	
13	68D-G2119-00	GRIP, STEERING HANDLE POIGNEE, BARRE FRANCHE		1	
14	68D-G2137-00	INDICATOR, THROTTLE INDICATEUR, ACCELERATION		1	
15	90269-02M09	RIVET RIVET		1	
16	67D-42177-00	RUBBER, HANDLE CAOUTCHOUC, POIGNEE		1	
17	90149-05M13	SCREW VIS		1	
18	92903-10600	WASHER, PLATE RONDELLE, PLATE		1	
19	90501-23215	SPRING, COMPRESSION RESSORT, COMPRESSION		1	
20	90386-08032	BUSH DOUILLE		1	
21	69M-G2138-00	LEVER, THROTTLE LEVIER, ACCELERATEUR		1	
22	68D-G2159-00	STAY SUPPORT		1	
23	97885-05012	SCREW, PAN HEAD VIS, A ENCOCHE		2	
24	68D-F6301-00	THROTTLE CABLE ASSY CABLE D'ACCELERATEUR		1	
25	6E0-83627-41	LABEL, CAUTION 7 ETIQUETTE, RECOMMANDATION 7		1	
26	6E0-83627-51	LABEL, CAUTION 7 ETIQUETTE, RECOMMANDATION 7		1	
27	6A1-2415A-41	LABEL, CAUTION ETIQUETTE, RECOMMANDATION		1	

**FIG. 13 STEERING**

**DIRECTION**

REF. NO.	PART NO. NO. PIECES	DESCRIPTION DESCRIPTION	F4A	REMARKS REMARQUES
28	6A1-2415A-51	LABEL, CAUTION ETIQUETTE, RECOMMANDATION	1	
29	68D-E571Y-60	MARK, CAUTION MARKER	1	
30	6N0-F8176-00	LABEL, CAUTION ETIQUETTE, RECOMMANDATION	1	

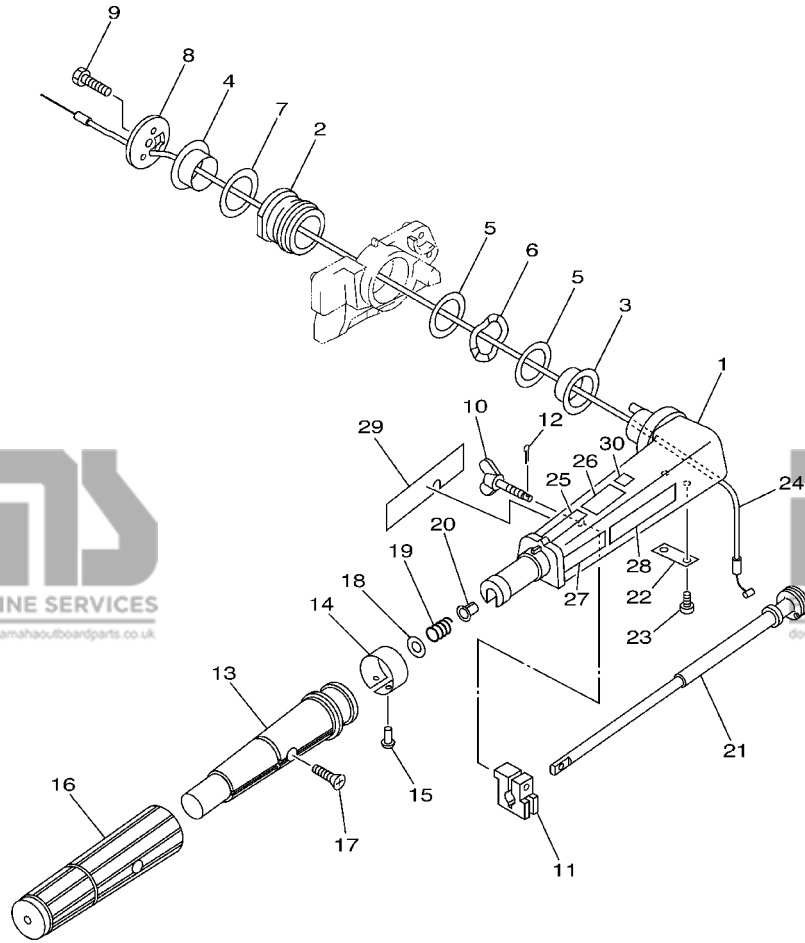

68D3300-3130

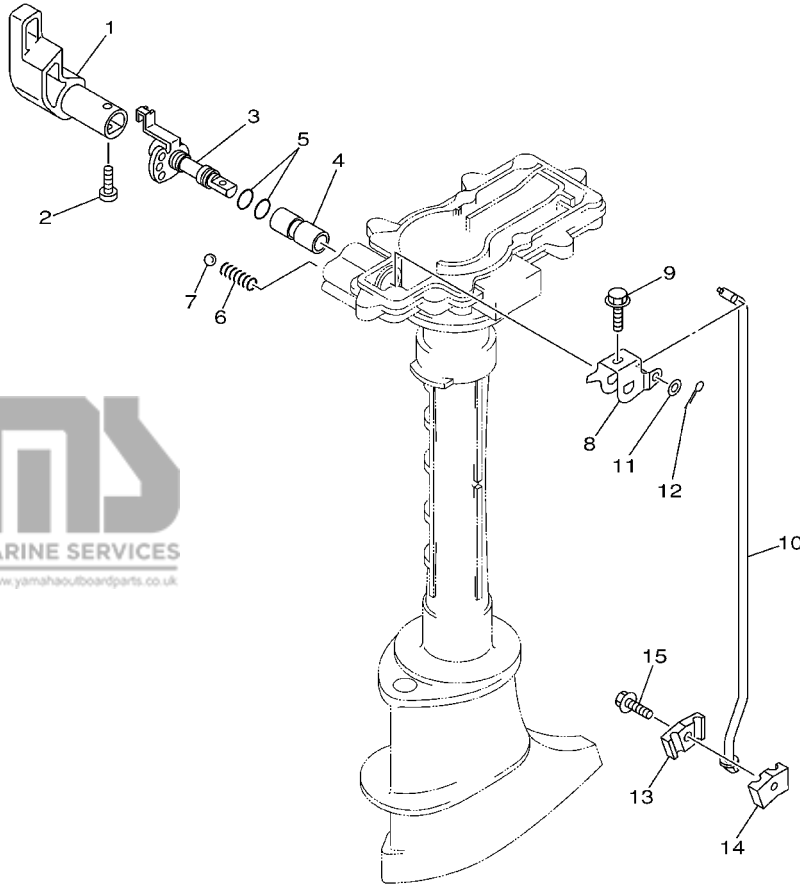

67D0010-0141

**FIG. 14 CONTROL**

**COMMANDE**

REF. NO.	PART NO. NO. PIECES	DESCRIPTION DESCRIPTION	F4A	REMARKS REMARQUES
1	68D-G4111-00	HANDLE, GEAR SHIFT POIGNEE, LEVIER D'EMBRAYAGE	1	
2	98680-05520	SCREW, OVAL HEAD VIS, TETE FRAISEE BOMBEE	1	
3	68D-G4119-00	SHAFT, CHANGE ARBRE, SELECTION	1	
4	68D-G4122-01	BUSHING, SHIFT ROD LEVER DOUILLE, LEVIER D'EMBRAYAGE	1	
5	93210-09350	O-RING JOINT TORIQUE	2	
6	90501-12274	SPRING, COMPRESSION RESSORT, COMPRESSION	1	
7	93505-16024	BALL BILLE ROULEMENT	1	
8	68D-G4121-00	LEVER, SHIFT ROD LEVIER, TIGE D'INVERSION	1	
9	90119-05M04	BOLT, WITH WASHER BOULON, AVEC RONDELLE	1	
10	67D-44143-01	ROD, SHIFT TIGE D'EMBRAYAGE	1	
11	92990-05600	WASHER, PLATE RONDELLE, PLATE	1	
12	91490-16010	PIN, COTTER GOUPILLE	1	
13	68D-G4145-00	CONNECTOR, SHIFT ROD CONNECTEUR, TIGE D'INVERSION	1	
14	68D-G4146-00	CONNECTOR, SHIFT ROD CONNECTEUR, TIGE D'INVERSION	1	
15	90119-06ME0	BOLT, WITH WASHER BOULON, AVEC RONDELLE	1	

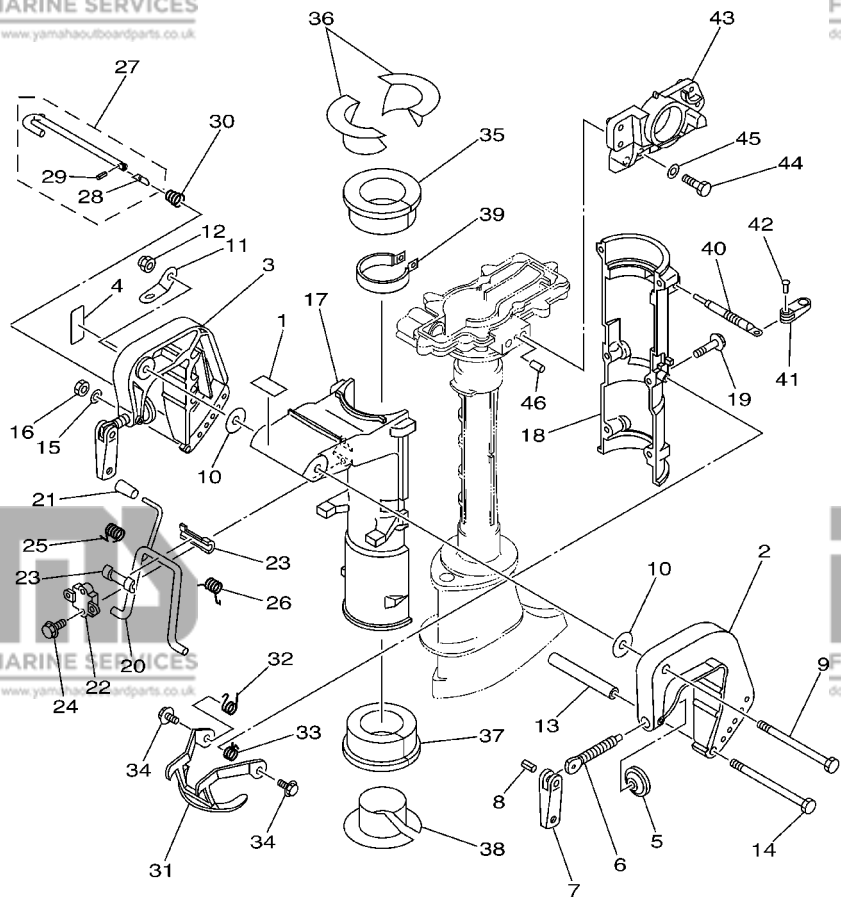

**FWD**  
68D2010-2150

**FIG. 15 BRACKET**

**SUPPORT**

REF. NO.	PART NO. NO. PIECES	DESCRIPTION DESCRIPTION	F4A	REMARKS REMARQUES
1	68D-F4591-00	EMBLEM, FUEL COCK ADHESIF	1	
2	6L8-G3111-01-4D	BRACKET, CLAMP PRESSE	1	
3	6L8-G3112-00-4D	BRACKET, CLAMP PRESSE	1	
4	6M0-G3318-00	COVER CAPUCHON	1	
5	620-43114-00	PAD, TRANSOM CLAMP RONDELLE D'APPUI	2	
6	6E0-43116-01	SCREW, TRANSOM CLAMP VIS DE PRESSE	2	
7	6L8-G3118-01	HANDLE, TRANSOM CLAMP POIGNEE DE VIS DE PRESSE	2	
8	90243-04M01	PIN GOUPILLE	2	
9	90101-08M07	BOLT BOULON	1	
10	90202-08M58	WASHER, PLATE RONDELLE, PLATE	2	
11	68D-G3113-00	PLATE, CLAMP BRACKET PLAQUETTE, PRESSE	1	
12	90185-08057	NUT, SELF-LOCKING ECROU, AUTO-BLOCANT	1	
13	90387-06M11	COLLAR COLLERETTE	1	
14	90101-06335	BOLT BOULON	1	
15	92990-06600	WASHER, PLATE RONDELLE, PLATE	1	
16	95380-06600	NUT, HEXAGON ECROU	1	
17	68D-G3311-00-4D	BRACKET, SWIVEL 1 SUPPORT, PIVOT 1	1	
18	68D-G3312-00-4D	BRACKET, SWIVEL 2 SUPPORT, PIVOT 2	1	
19	95895-06035	BOLT, FLANGE BOULON	6	
20	6E0-43181-00	LEVER, TILT STOP LEVIER, VERROUILLAGE RELEVAGE	1	
21	6E0-43632-00	KNOB, TILT POIGNEE, LEVIER DE RELEVAGE	1	
22	6E0-43313-00-4D	BRACKET, SWIVEL 3 SUPPORT, PIVOT 3	1	
23	620-43189-00	BUSHING COUSSINET	2	
24	95895-06020	BOLT, FLANGE BOULON	2	
25	90508-16020	SPRING, TORSION RESSORT, TORSION	1	
26	90508-16021	SPRING, TORSION RESSORT, TORSION	1	
27	68D-G3160-00	TILT ROD ASSY BROCHE D'INCLINAISON (ENS.)	1	



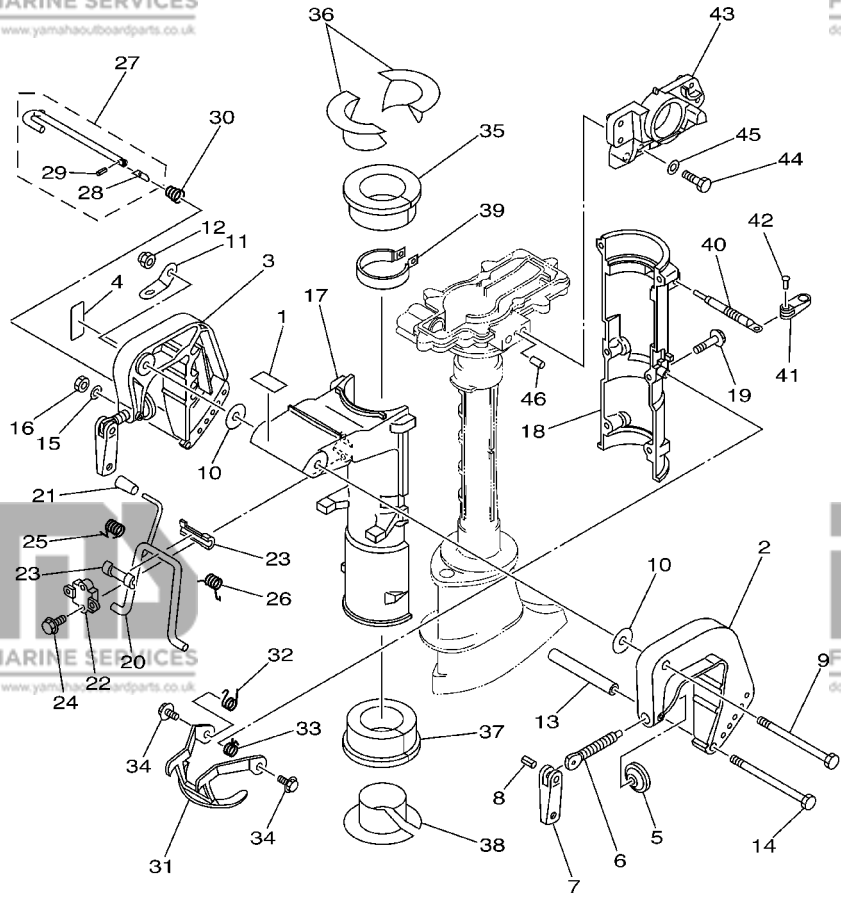

**FIG. 15 BRACKET**

**SUPPORT**

REF. NO.	PART NO. NO. PIECES	DESCRIPTION DESCRIPTION	F4A	REMARKS REMARQUES
28	6N0-G3165-00	.PLATE, TILT LOCK .TAQUET, BROCHE INCLINAISON	1	
29	91690-30008	.PIN, SPRING .AGRAFFE	1	
30	90502-08M05	SPRING, CONICAL RESSORT, CONIQUE	1	
31	6E0-43614-00-5B	PLATE, TILT LOCK ETRIER, VERROUILLAGE MARCHE AR	1	
32	90508-14M10	SPRING, TORSION RESSORT, TORSION	1	
33	90508-14M11	SPRING, TORSION RESSORT, TORSION	1	
34	95895-06010	BOLT, FLANGE BOULON	2	
35	68D-G2537-00	BUSHING, PIVOT SHAFT COUSSINET	1	
36	68D-G2539-00	BUSHING, PIVOT SHAFT COUSSINET	2	
37	68D-G2538-00	BUSHING, PIVOT SHAFT COUSSINET	1	
38	68D-G2549-00	BUSHING, PIVOT SHAFT COUSSINET	1	
39	6E0-42528-03	PLATE, FRICTION PLAQUE, FRICTION	1	
40	6L5-42529-01	SCREW, FRICTION PIECE VIS, PIECE DE FRICTION	1	
41	68D-G2561-01	KNOB, STEERING LOCK BOUTON	1	
42	90266-04M05	RIVET RIVET	1	
43	68D-G2511-00-4D	BRACKET, STEERING CADRE, DIRECTION	1	
44	97075-08030	BOLT BOULON	2	
45	92995-08600	WASHER RONDELLE	2	
46	93604-12M07	PIN, DOWEL CLAVETTE	1	



68D2010-2150

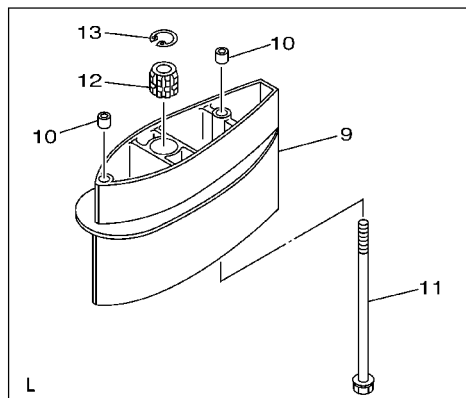
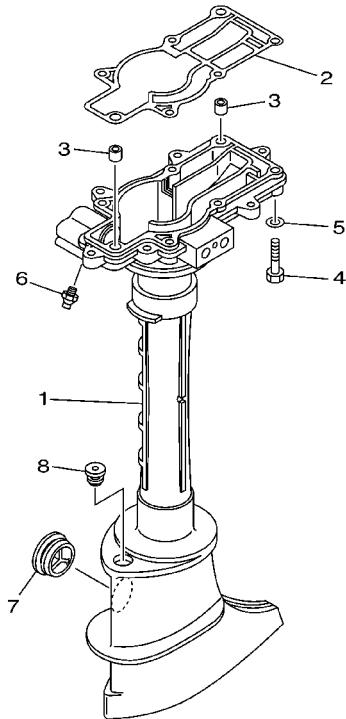

**FWD**  
68D2010-2160

**FIG. 16 UPPER CASING**

**FOURREAU**

REF. NO.	PART NO. NO. PIECES	DESCRIPTION DESCRIPTION	F4A	REMARKS REMARQUES
1	68D-G5111-01-4D	CASING, UPPER FOURREAU	1	
2	68D-G5113-A0	GASKET, UPPER CASING JOINT, TUBE D'ARBRE	1	
3	90387-06806	COLLAR COLLERETTE	2	
4	97095-06035	BOLT BOULON	7	
5	92995-06600	WASHER RONDELLE	7	
6	93700-06M03	NIPPLE, GREASE PION	1	
7	647-45151-01	COVER, UPPER CASING CAPUCHON, FOURREAU	1	
8	90480-10M13	GROMMET PASSE-FIL	1	
9	68D-G5211-00-4D	EXTENSION EXTENSION	1	L
10	90387-06806	COLLAR COLLERETTE	2	L
11	90119-06M77	BOLT, WITH WASHER BOULON, AVEC RONDELLE	2	L
12	6E0-45318-01	BUSHING, DRIVE SHAFT DOUILLE, ARBRE MOTEUR	1	L
13	93420-22M03	CIRCLIP CIRCLIP, TYPE S	1	L

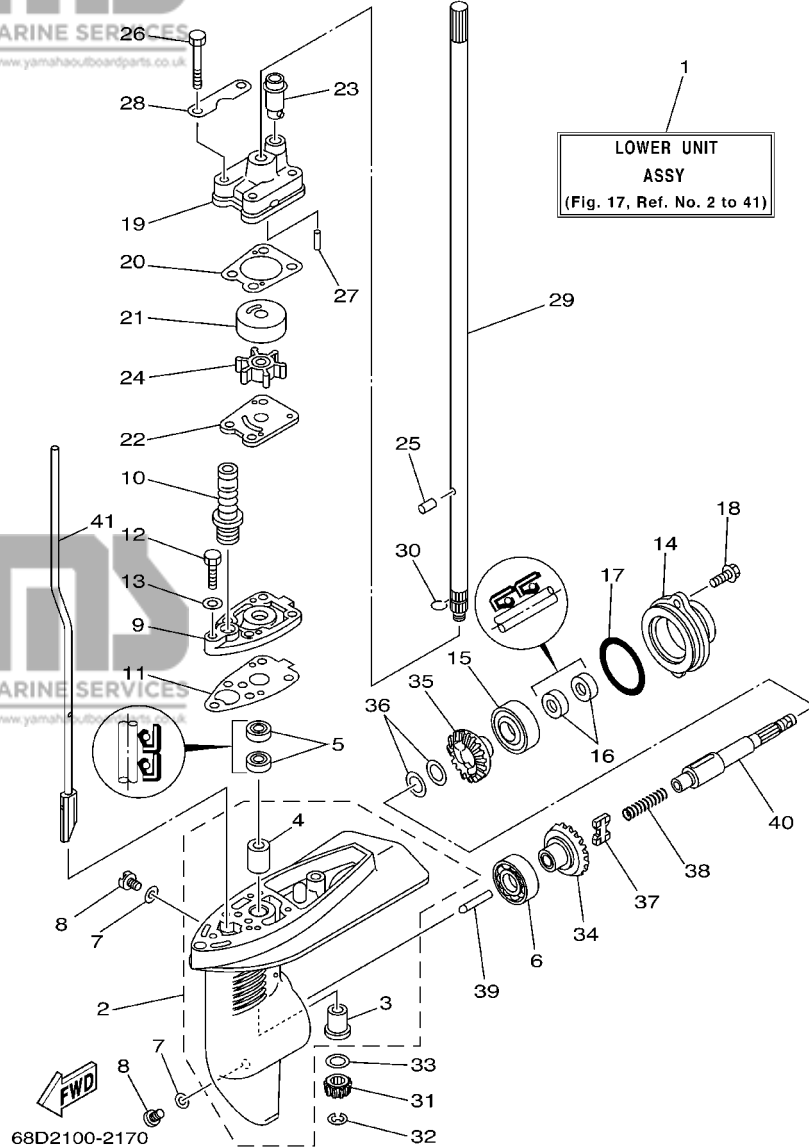

FIG. 17 LOWER CASING. DRIVE 1

BOITIER D'HELICE, TRANSMISSION 1

REF. NO.	PART NO. NO. PIECES	DESCRIPTION DESCRIPTION	F4A	REMARKS REMARQUES
1	68D-G5300-01-4D	LOWER UNIT ASSY UNITE INFERIEURE (ENS.)	1	S
	68D-G5300-11-4D	LOWER UNIT ASSY UNITE INFERIEURE (ENS.)	1	L
2	68D-G5311-00-4D	CASING, LOWER BOITIER D'HELICE	1	
3	6E0-45317-09	.BUSHING, DRIVE SHAFT .DOUILLE, ARBRE MOTEUR	1	
4	6E0-45316-09	.BUSHING, DRIVE SHAFT .DOUILLE, ARBRE MOTEUR	1	
5	93101-10M14	OIL SEAL JOINT SPY	2	
6	93306-004YH	BEARING ROULEMENT	1	
7	90430-08801	GASKET JOINT	3	
8	90340-08002	PLUG, STRAIGHT SCREW PLOT, FILETE DROIT	3	
9	68D-G5321-00	PLATE PLAQUETTE	1	
10	6L2-44147-00	BOOT, SHIFT ROD SOUFFLET, TIGE D'INVERSION	1	
11	68D-G5315-A0	PACKING, LOWER CASING JOINT, BOITIER D'HELICE	1	
12	97095-06025	BOLT BOULON	1	
13	92995-06600	WASHER RONDELLE	1	
14	68D-G5361-00-4D	CAP, LOWER CASING COUVERCLE, BOITIER D'HELICE	1	
15	93306-004YH	BEARING ROULEMENT	1	
16	93101-13M12	OIL SEAL JOINT SPY	2	
17	93210-48214	O-RING JOINT TORIQUE	1	
18	95895-06016	BOLT, FLANGE BOULON	2	
19	68D-G4311-01	HOUSING, WATER PUMP CORPS, POMPE A EAU	1	
20	68D-G4315-A0	GASKET, WATER PUMP JOINT, POMPE A EAU	1	
21	68D-G4322-00	INSERT, CARTRIDGE CUVETTE	1	
22	6E0-44323-00	OUTER PLATE, CARTRIDGE PLAQUE EXTERIEURE	1	
23	67D-44366-00	DAMPER, WATER SEAL JOINT, TUBE D'EAU	1	
24	6E0-44352-00	IMPELLER TURBINE	1	
25	93604-09066	PIN, DOWEL CLAVETTE	1	
26	97095-06045	BOLT BOULON	4	

D4

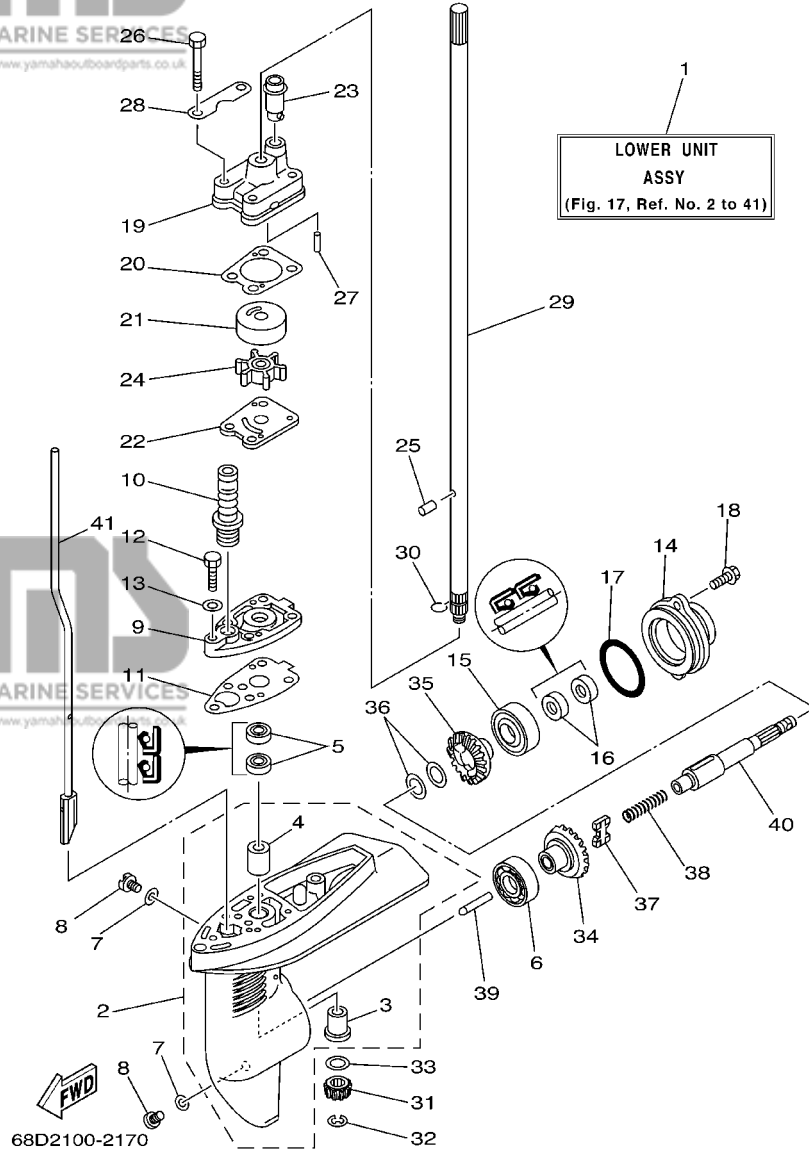
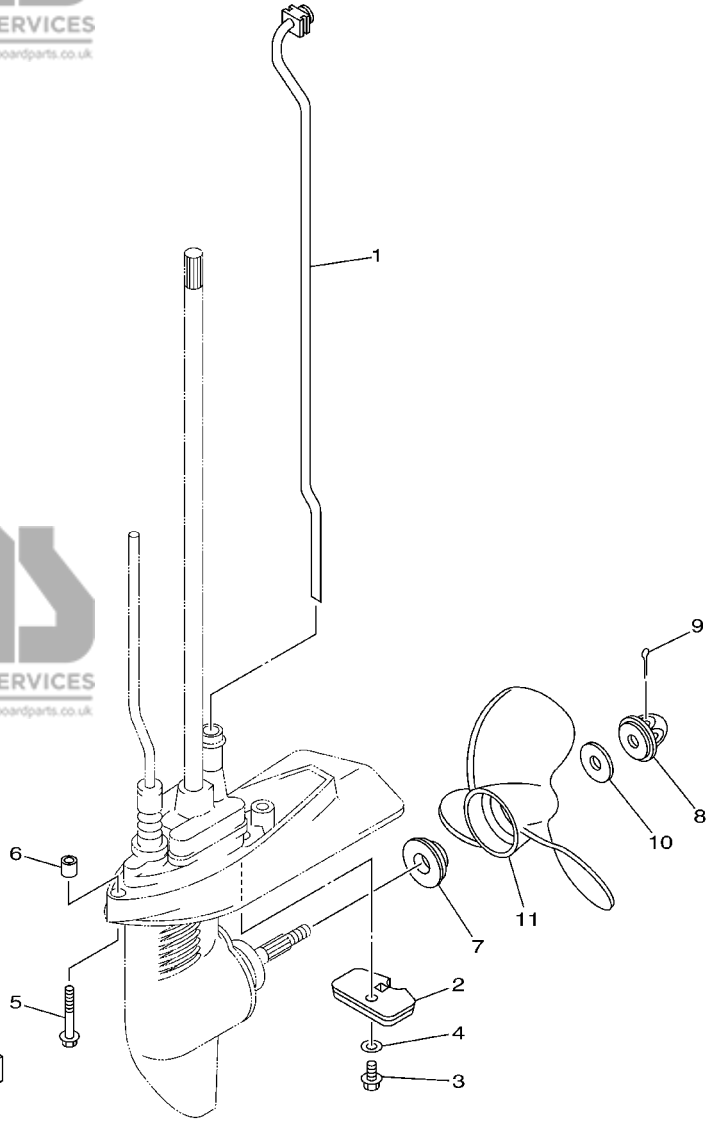

FIG. 17 LOWER CASING. DRIVE 1

BOITIER D'HELICE, TRANSMISSION 1

REF. NO.	PART NO. NO. PIECES	DESCRIPTION DESCRIPTION	F4A	REMARKS REMARQUES
27	93604-18080	PIN, DOWEL CLAVETTE	2	
28	68D-G4328-00	PLATE PLAQUETTE	2	
29	68D-G5511-00	SHAFT, DRIVE ARBRE, MOTEUR	1	S
	68D-G5511-10	SHAFT, DRIVE ARBRE, MOTEUR	1	L
30	90467-08M01	CLIP JONC	1	
31	6E0-45551-00	PINION PIGNON D'ATTAQUE	1	
32	99001-06600	CIRCLIP CIRCLIP	1	
33	90201-11M49	WASHER, PLATE RONDELLE, PLATE	1	
34	67D-45560-00	GEAR PIGNON	1	
35	67D-45570-00	GEAR PIGNON	1	
36	67D-45576-00	WASHER, THRUST RONDELLE DE CALAGE	2	
37	67D-45631-01	CLUTCH, DOG CRABOT	1	
38	90501-10064	SPRING, COMPRESSION RESSORT, COMPRESSION	1	
39	67D-45635-00	PLUNGER, SHIFT POUSSOIR D'EMBRAYAGE	1	
40	68D-G5611-10	SHAFT, PROPELLER ARBRE, HELICE	1	
41	68D-G4150-00	SHIFT CAM ASSY CAME D'INVERSION	1	S
	68D-G4150-10	SHIFT CAM ASSY CAME D'INVERSION	1	L

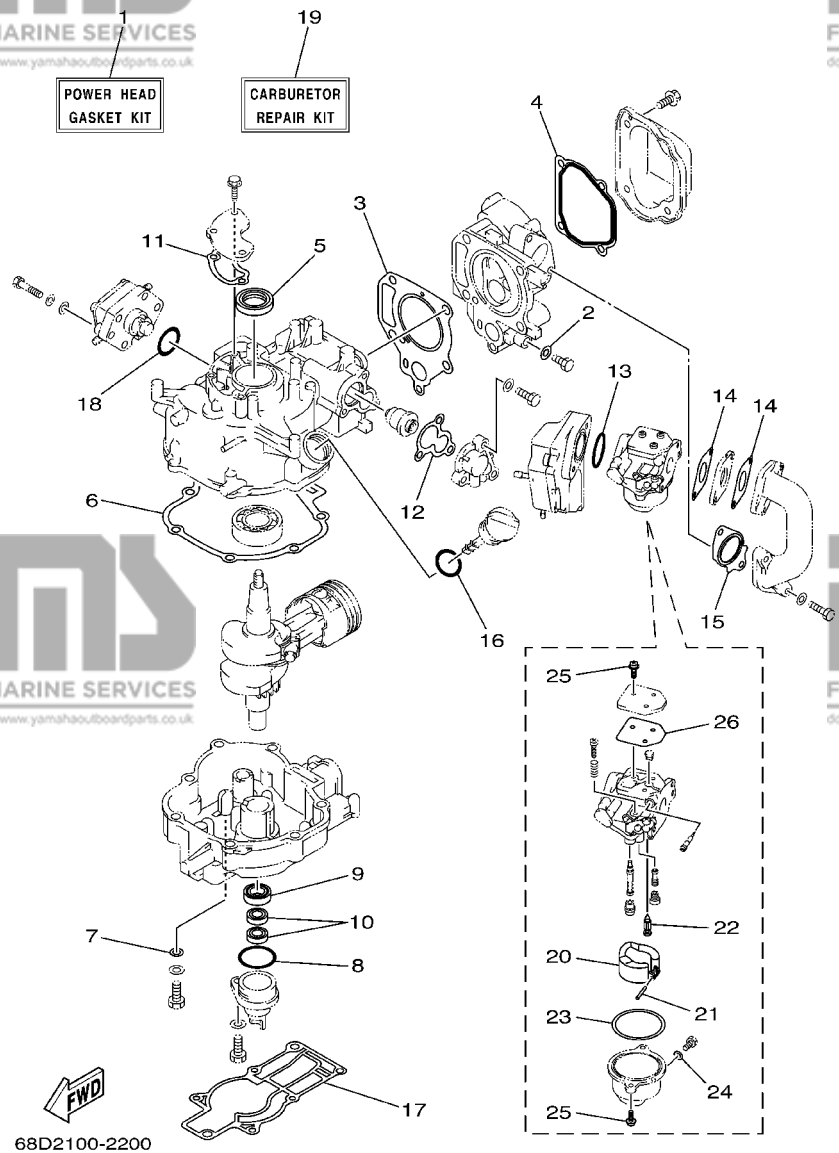

**FIG. 18 LOWER CASING. DRIVE 2**

**BOITIER D'HELICE, TRANSMISSION 2**

REF. NO.	PART NO. NO. PIECES	DESCRIPTION DESCRIPTION	F4A	REMARKS REMARQUES
1	68D-G4360-00	WATER TUBE ASSY TUYAU,EAU	1	S
	68D-G4360-10	WATER TUBE ASSY TUYAU,EAU	1	L
2	68D-G5251-00	ANODE ANODE	1	
3	95895-06012	BOLT, FLANGE BOULON	1	
4	92990-06300	WASHER, INTERNAL TOOTH RONDELLE, DENTURE INTERNE	1	
5	90119-06M40	BOLT, WITH WASHER BOULON, AVEC RONDELLE	2	S
6	90387-06806	COLLAR COLLERETTE	2	
7	68D-G5987-00	SPACER ENTRETOISE	1	
8	6L5-45616-00	NUT, PROPELLER CONE, HELICE	1	
9	91490-25030	PIN, COTTER GOUPILLE	1	
10	90201-08M54	WASHER, PLATE RONDELLE, PLATE	1	
11	6E0-45941-01-EL	PROPELLER (3X7-1/2"X8"-BA) HELICE (3X7-1/2"X8"-BA)	1	UR
	6E0-45943-01-EL	PROPELLER (3X7-1/2"X7"-BA) HELICE (3X7-1/2"X7"-BA)	1	UR
	6E0-45949-00-EL	PROPELLER (3X7-1/4"X6-1/2"-BA) HELICE (3X7-1/4"X6-1/2"-BA)	1	UR

**D6**



**FIG. 19 REPAIR KIT 1**

**KITS DE REPARATION 1**

REF. NO.	PART NO. NO. PIECES	DESCRIPTION DESCRIPTION	F4A	REMARKS REMARQUES
1	68D-WE001-00	POWER HEAD GASKET KIT POCHETTE DE JINTS TETE MOTRICE	1	
2	90430-08800	.GASKET .JOINT	1	
3	67D-11181-A0	.GASKET, CYLINDER HEAD 1 .JOINT, DE CULASSE 1	1	
4	68D-E1193-A0	.GASKET, HEAD COVER 1 .JOINT, COUVERCLE DE CULASSE 1	1	
5	93102-25090	.OIL SEAL .JOINT SPY	1	
6	68D-11351-A0	.GASKET, CYLINDER .JOINT, D'EMBASE	1	
7	90201-08818	.WASHER, PLATE .RONDELLE, PLATE	1	
8	93210-35537	.O-RING .JOINT TORIQUE	1	
9	93102-20108	.OIL SEAL .JOINT SPY	1	
10	93102-10004	.OIL SEAL .JOINT SPY	2	
11	68D-E1169-A0	.GASKET, BREATHER COVER .JOINT, COUVERCLE DE RENIFLARD	1	
12	68D-E2414-A0	.GASKET, COVER .JOINT, COUVERCLE	1	
13	93210-31MJ5	.O-RING .JOINT TORIQUE	1	
14	68D-E3646-A0	.GASKET, MANIFOLD 2 .JOINT, TUBULURE 2	2	
15	68D-E3645-A0	.GASKET, MANIFOLD 1 .JOINT, TUBULURE 1	1	
16	93210-24M79	.O-RING .JOINT TORIQUE	1	
17	68D-G5113-A0	.GASKET, UPPER CASING .JOINT, TUBE D'ARBRE	1	
18	93210-27ME3	.O-RING .JOINT TORIQUE	1	
19	67D-W0093-01	CARBURETOR REPAIR KIT KIT DE REPARATION CARBURATEUR	1	
20	68T-14385-00	.FLOAT .FLOTTEUR	1	
21	67D-14386-00	.PIN, FLOAT .AXE, FLOTTEUR	1	
22	67D-14546-00	.VALVE, NEEDLE .POINTEAU	1	
23	67D-14984-00	.GASKET, FLOAT CHAMBER .JOINT, CUVE DE FLOTTEUR	1	
24	6J8-14959-00	.GASKET .JOINT	1	
25	97980-04112	.SCREW, WITH WASHER .VIS, AVEC RONDELLE	2	
26	67D-14536-00	.GASKET .JOINT	1	

**D7**

LOWER UNIT  
GASKET KIT

8  
WATER PUMP  
REPAIR KIT

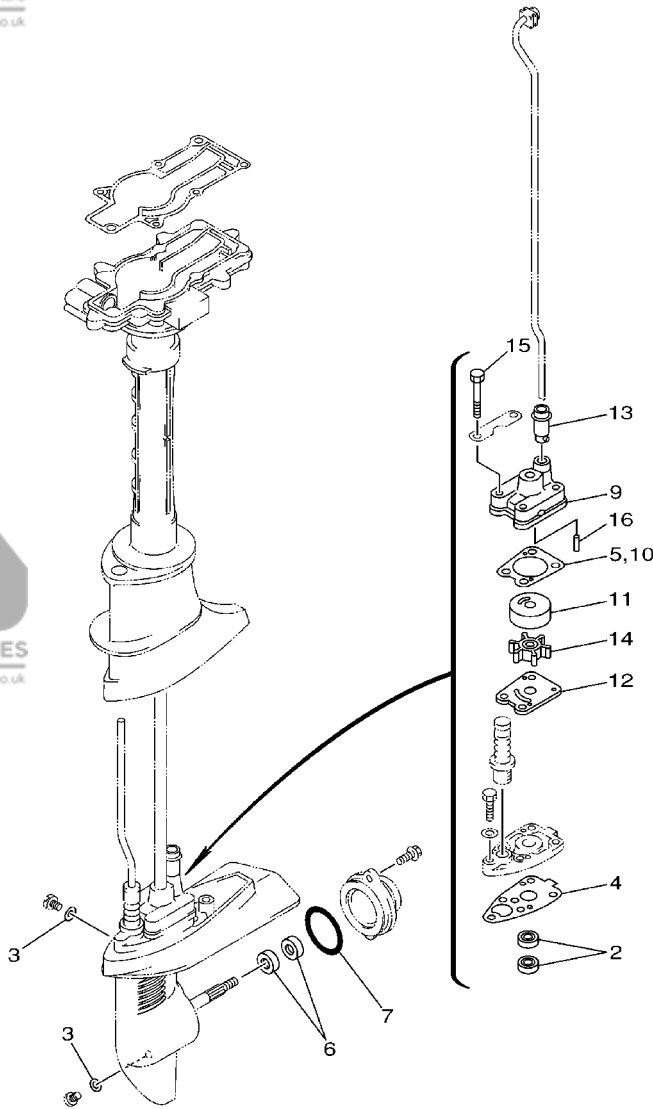

68D2100-2210

FIG. 20 REPAIR KIT 2

KITS DE REPARATION 2

REF. NO.	PART NO. NO. PIECES	DESCRIPTION DESCRIPTION	F4A	REMARKS REMARQUES
1	6E0-W0001-C1	LOWER UNIT GASKET KIT POCHETTE DE JOINTS EMBASE	1	
2	93101-10M14	.OIL SEAL .JOINT SPY	2	
3	90430-08801	.GASKET .JOINT	3	
4	68D-G5315-A0	.PACKING, LOWER CASING .JOINT, BOITIER D'HELICE	1	
5	68D-G4315-A0	.GASKET, WATER PUMP .JOINT, POMPE A EAU	1	
6	93101-13M12	.OIL SEAL .JOINT SPY	2	
7	93210-48214	.O-RING .JOINT TORIQUE	1	
8	68D-WG078-00	WATER PUMP REPAIR KIT KIT DE REPARATION DE LA POMPE	1	
9	68D-G4311-01	.HOUSING, WATER PUMP .CORPS, POMPE A EAU	1	
10	68D-G4315-A0	.GASKET, WATER PUMP .JOINT, POMPE A EAU	1	
11	68D-G4322-00	.INSERT, CARTRIDGE .CUVETTE	1	
12	6E0-44323-00	.OUTER PLATE, CARTRIDGE .PLAQUE EXTERIEURE	1	
13	67D-44366-00	.DAMPER, WATER SEAL .JOINT, TUBE D'EAU	1	
14	6E0-44352-00	.IMPELLER .TURBINE	1	
15	97095-06045	.BOLT .BOULON	4	
16	93604-18080	.PIN, DOWEL .CLAVETTE	2	

**NUMERICAL INDEX  
INDEX NUMERIQUE**

**PART NO.  
NO. PIECES**

**REF.  
NO.**

68D-E1111-10-94 2 - 2  
68D-E1168-00 4 - 21  
68D-E1169-A0 4 - 22  
19 - 11  
68D-E1193-A0 2 - 12  
19 - 4  
68D-E1311-01-94 4 - 1  
68D-E1325-00 2 - 17  
68D-E1603-00 3 - 6  
68D-E1604-00 3 - 6  
68D-E1605-00 3 - 6  
68D-E1631-00-96 3 - 5  
68D-E1633-00 3 - 7  
68D-E1635-00 3 - 5  
68D-E1636-00 3 - 5  
68D-E2113-00 5 - 6  
68D-E2138-60 12 - 20  
68D-E2155-00 5 - 13  
68D-E2170-00 5 - 1  
68D-E2413-00-9M 2 - 15  
68D-E2414-A0 2 - 19  
19 - 12  
68D-E3102-00 4 - 26  
68D-E3641-00-94 6 - 11  
68D-E3645-A0 6 - 12  
19 - 15  
68D-E3646-A0 6 - 9  
19 - 14  
68D-E3647-00 6 - 10  
68D-E4440-00 6 - 1  
68D-E5111-00-94 4 - 7  
68D-E5346-00 4 - 24  
68D-E5362-00 4 - 28  
68D-E5396-00-5B 4 - 15  
68D-E571Y-60 13 - 29  
68D-F4111-00 8 - 1  
68D-F4311-00 8 - 12  
68D-F4312-00 9 - 4  
68D-F4313-00 9 - 8  
68D-F4314-00 6 - 7  
68D-F4500-00 9 - 6  
68D-F4591-00 15 - 1  
68D-F6301-00 13 - 24  
68D-F6330-00 6 - 15  
68D-F8100-00 9 - 37  
6N0-F8176-00 13 - 30  
68D-F8199-72-A0 9 - 38  
68D-F8199-72-B0 9 - 38

**PART NO.  
NO. PIECES**

**REF.  
NO.**

68D-F8199-82-A0 9 - 39  
68D-F8199-82-B0 9 - 39  
68D-G2111-00-4D 13 - 1  
68D-G2119-00 13 - 13  
6N0-G2126-00 13 - 11  
68D-G2131-01 13 - 8  
68D-G2137-00 13 - 14  
69M-G2138-00 13 - 21  
68D-G2159-00 13 - 22  
68D-G2171-00 13 - 3  
68D-G2172-00 13 - 4  
68D-G2181-00 13 - 5  
68D-G2182-00 13 - 7  
69M-G2188-00 13 - 6  
68D-G2511-00-4D 15 - 43  
68D-G2537-00 15 - 35  
68D-G2538-00 15 - 37  
68D-G2539-00 15 - 36  
68D-G2549-00 15 - 38  
68D-G2561-01 15 - 41  
68D-G2610-40-4D 1 - 1  
68D-G2613-01 1 - 2  
68D-G2628-00 12 - 2  
68D-G2629-00 12 - 4  
68D-G2677-00 1 - 5  
68D-G2678-00 1 - 6  
68D-G2711-01 12 - 1  
68D-G2712-01 12 - 3  
68D-G2731-00 12 - 13  
68D-G2735-00 12 - 14  
6L8-G3111-01-4D 15 - 2  
6L8-G3112-00-4D 15 - 3  
68D-G3113-00 15 - 11  
6L8-G3118-01 15 - 7  
68D-G3160-00 15 - 27  
6N0-G3165-00 15 - 28  
68D-G3311-00-4D 15 - 17  
68D-G3312-00-4D 15 - 18  
6M0-G3318-00 15 - 4  
68D-G4111-00 14 - 1  
68D-G4119-00 14 - 3  
68D-G4121-00 14 - 8  
68D-G4122-01 14 - 4  
68D-G4145-00 14 - 13  
68D-G4146-00 14 - 14  
68D-G4150-00 17 - 41  
68D-G4150-10 17 - 41  
68D-G4311-01 17 - 19

**PART NO.  
NO. PIECES**

**REF.  
NO.**

68D-G4311-01 20 - 9  
68D-G4315-A0 17 - 20  
20 - 5  
20 - 10  
68D-G4322-00 17 - 21  
20 - 11  
68D-G4328-00 17 - 28  
68D-G4360-00 18 - 1  
68D-G4360-10 18 - 1  
68D-G5111-01-4D 16 - 1  
68D-G5113-A0 16 - 2  
19 - 17  
68D-G5211-00-4D 16 - 9  
68D-G5251-00 18 - 2  
68D-G5300-01-4D 17 - 1  
68D-G5300-11-4D 17 - 1  
68D-G5311-00-4D 17 - 2  
68D-G5315-A0 17 - 11  
20 - 4  
68D-G5321-00 17 - 9  
68D-G5361-00-4D 17 - 14  
68D-G5511-00 17 - 29  
68D-G5511-10 17 - 29  
68D-G5611-10 17 - 40  
68D-G5987-00 18 - 7  
68D-H257H-00 12 - 21  
68D-WE001-00 19 - 1  
68D-WE090-10-4D 2 - 1  
68D-WG070-00 1 - 4  
68D-WG078-00 20 - 8  
6E0-W0001-C1 20 - 1  
67D-W0093-01 19 - 19  
67D-11133-10 2 - 3  
67D-11181-A0 2 - 10  
19 - 3  
67D-11191-00 2 - 11  
68D-11351-A0 4 - 9  
19 - 6  
67D-11400-00 3 - 1  
67D-11650-00 3 - 3  
67D-11654-00 3 - 4  
67D-12111-00 5 - 2  
68T-12116-00 5 - 5  
7NJ-12117-00 5 - 7  
7NJ-12118-00 5 - 8  
51Y-12119-00 5 - 4  
67D-12121-00 5 - 3  
67D-12151-00 5 - 9

**PART NO.  
NO. PIECES**

**REF.  
NO.**

JA9-12153-00 5 - 15  
67D-12154-00 5 - 14  
67D-12157-00 5 - 12  
7FK-12158-00 5 - 11  
7FK-12165-00 5 - 10  
66M-12411-00 2 - 14  
67D-13131-00 9 - 22  
67F-13434-02 1 - 8  
68D-13437-60 10 - 29  
67D-13444-50 12 - 19  
67D-14126-00 7 - 19  
67D-14301-01 7 - 1  
67D-14301-20 7 - 1  
6E5-14321-00 7 - 2  
67D-14323-00 7 - 16  
68T-14323-20 7 - 16  
6E7-14325-00 9 - 19  
6J8-14334-00 7 - 3  
68T-14385-00 7 - 4  
19 - 20  
67D-14386-00 7 - 6  
19 - 21  
10 - 30  
67D-14427-60 10 - 30  
6H1-14485-00 4 - 3  
67D-14527-00 7 - 18  
67D-14536-00 7 - 17  
19 - 26  
67D-14546-00 7 - 7  
19 - 22  
67D-1492A-00 7 - 10  
67D-1492E-34 7 - 8  
67D-1492F-18 7 - 9  
6J8-14959-00 7 - 13  
19 - 24  
67D-14966-00 7 - 5  
67D-14981-00 7 - 12  
67D-14984-00 7 - 11  
19 - 23  
7 - 14  
66T-14991-00 7 - 14  
67D-15705-00 10 - 8  
67D-15710-00 10 - 1  
6L5-42529-01 10 - 2  
67D-15713-00 10 - 7  
67D-15714-00 10 - 5  
67D-15723-00 11 - 6  
67D-15734-00 10 - 14  
67D-15735-00 10 - 10  
67D-15739-00 10 - 18

**PART NO.  
NO. PIECES**

**REF.  
NO.**

67D-15741-00 10 - 6  
6G1-15755-00 10 - 16  
67D-15762-00 10 - 19  
63V-15764-00 10 - 12  
67D-15764-00 10 - 4  
67D-15767-00 10 - 9  
67D-15770-00 10 - 25  
67D-15772-00 10 - 24  
6G1-15779-00 10 - 17  
67D-15793-00 10 - 11  
67D-15794-00 10 - 13  
63V-15795-01 10 - 3  
6H1-21757-00 8 - 6  
6A1-2415A-41 13 - 27  
6A1-2415A-51 13 - 28  
6G8-2415E-00 12 - 22  
6L5-24251-00 8 - 11  
646-24251-02 9 - 11  
6G1-24304-02 9 - 1  
66M-24374-00 9 - 23  
650-24378-00 2 - 16  
4 - 2  
4 - 8  
67D-24410-02 9 - 15  
67D-24411-00 9 - 20  
67D-24412-00 9 - 16  
67D-24413-02 9 - 17  
67D-24414-01 9 - 25  
6A0-24421-01 9 - 18  
67D-24423-00 9 - 21  
67D-24444-00 9 - 27  
67D-24454-00 9 - 24  
66M-24471-00 9 - 26  
67D-24610-02 8 - 2  
69M-24633-00 8 - 5  
624-24634-00 8 - 4  
6L5-24641-00 8 - 7  
6G1-42125-01 13 - 10  
67D-42129-00 13 - 2  
67D-42177-00 13 - 16  
6E0-42528-03 15 - 39  
6L5-42529-01 15 - 40  
624-42542-00 8 - 9  
6L5-42647-00 12 - 7  
67D-42662-00 12 - 15  
68D-42662-00 1 - 7  
67D-42791-10 10 - 26  
6L5-42823-00 12 - 8

**PART NO.  
NO. PIECES**

**REF.  
NO.**

620-43114-00 15 - 5  
6E0-43116-01 15 - 6  
6E0-43181-00 15 - 20  
620-43189-00 15 - 23  
6E0-43313-00-4D 15 - 22  
6E0-43614-00-5B 15 - 31  
6E0-43632-00 15 - 21  
67D-44143-01 14 - 10  
6L2-44147-00 17 - 10  
6E0-44323-00 17 - 22  
20 - 12  
6E0-44352-00 17 - 24  
20 - 14  
67D-44366-00 17 - 23  
20 - 13  
647-45151-01 16 - 7  
6E0-45316-09 17 - 4  
6E0-45317-09 17 - 3  
6E0-45318-01 16 - 12  
6E0-45551-00 17 - 31  
67D-45560-00 17 - 34  
67D-45570-00 17 - 35  
67D-45576-00 17 - 36  
6L5-45616-00 18 - 8  
67D-45631-01 17 - 37  
67D-45635-00 17 - 39  
6E0-45941-01-EL 18 - 11  
6E0-45943-01-EL 18 - 11  
6E0-45949-00-EL 18 - 11  
6A0-82317-00 8 - 8  
6E3-82370-21 11 - 8  
682-82556-00 11 - 11  
689-8257Y-00 11 - 12  
67D-82575-00 11 - 10  
6A1-83625-41 10 - 27  
6A1-83625-51 10 - 28  
6E0-83627-41 13 - 25  
6E0-83627-51 13 - 26  
67D-85640-00 11 - 2  
67D-85650-00 11 - 1  
90101-06335 15 - 14  
90101-08M07 15 - 9  
90105-06M14 2 - 13  
90105-06M24 11 - 7  
90105-06M25 2 - 8  
90105-08M36 2 - 6  
90105-08046 2 - 7  
90119-05M04 14 - 9



PART NO. NO. PIECES	REF. NO.
90119-06ME0	14 - 15
90119-06M40	18 - 5
90119-06M77	16 - 11
90119-06M79	12 - 16
90119-06M80	4 - 23
90119-06M88	8 - 10
90149-05M13	13 - 17
90159-06M10	9 - 7
90161-05001	12 - 11
90167-03M02	12 - 9
90170-10M33	11 - 4
90185-08057	15 - 12
90201-08M54	18 - 10
90201-08818	4 - 14
	19 - 7
90201-105A2	11 - 5
90201-11M49	17 - 33
90201-266P2	3 - 2
90202-08M58	15 - 10
90243-04M01	15 - 8
90266-04M05	15 - 42
90269-02M09	13 - 15
90280-04M06	11 - 3
90340-08002	17 - 8
90386-08032	13 - 20
90387-06M11	15 - 13
90387-06806	16 - 3
	16 - 10
	18 - 6
90430-08800	2 - 5
	19 - 2
90430-08801	17 - 7
	20 - 3
90445-07805	6 - 8
90445-07806	4 - 4
90445-09807	2 - 22
90445-10804	9 - 12
90445-10805	9 - 33
90446-14M12	9 - 13
	9 - 34
90464-05122	6 - 16
90464-07M50	12 - 17
90464-07078	12 - 18
90464-10M52	9 - 10
90464-10M53	9 - 35
90464-13249	6 - 3
90467-08M01	17 - 30
90467-09M09	9 - 5

PART NO. NO. PIECES	REF. NO.
90467-09M09	9 - 9
	9 - 14
	9 - 36
90467-13M13	8 - 13
90480-10M13	16 - 8
90480-10004	12 - 12
90480-18M74	6 - 6
90480-22M72	12 - 10
90480-25161	11 - 9
90501-10064	17 - 38
90501-10260	8 - 3
90501-12274	14 - 6
90501-23215	13 - 19
90502-08M05	15 - 30
90508-14M10	15 - 32
90508-14M11	15 - 33
90508-16020	15 - 25
90508-16021	15 - 26
91490-16010	13 - 12
	14 - 12
91490-25030	18 - 9
91690-30008	15 - 29
92903-10600	13 - 18
92990-05600	14 - 11
92990-06300	18 - 4
92990-06600	15 - 15
92995-06100	9 - 31
92995-06600	2 - 21
	6 - 5
	6 - 14
	9 - 3
	9 - 32
	10 - 21
	10 - 23
	11 - 14
	12 - 6
	16 - 5
	17 - 13
92995-08600	4 - 13
	4 - 20
	15 - 45
93101-10M14	17 - 5
	20 - 2
93101-13M12	17 - 16
	20 - 6
93102-10004	4 - 18
	19 - 10
93102-20108	4 - 17

NUMERICAL INDEX  
INDEX NUMERIQUE

PART NO. NO. PIECES	REF. NO.
93102-20108	19 - 9
93102-25090	4 - 5
	19 - 5
93210-09350	14 - 5
93210-24M79	4 - 29
	19 - 16
93210-27ME3	9 - 29
	19 - 18
93210-31MJ5	6 - 2
	19 - 13
93210-35537	4 - 16
	19 - 8
93210-48214	17 - 17
	20 - 7
93306-004YH	17 - 6
	17 - 15
93306-205YD	4 - 6
93420-22M03	16 - 13
93450-14088	3 - 8
93505-16024	14 - 7
93604-09066	17 - 25
93604-12M07	15 - 46
93604-18080	17 - 27
	20 - 16
93700-06M03	16 - 6
94702-00248	2 - 23
95380-05600	9 - 28
95380-06600	15 - 16
95817-06012	4 - 27
95895-06010	15 - 34
95895-06012	18 - 3
95895-06016	17 - 18
95895-06020	15 - 24
95895-06035	15 - 19
97075-08025	13 - 9
97075-08030	15 - 44
97095-06012	11 - 13
97095-06016	12 - 5
97095-06020	2 - 20
	10 - 22
97095-06025	6 - 13
	9 - 2
	17 - 12
97095-06030	9 - 30
97095-06035	10 - 20
	16 - 4
97095-06045	17 - 26
	20 - 15

PART NO. NO. PIECES	REF. NO.
97095-06090	6 - 4
97095-08014	2 - 4
97095-08020	4 - 12
	4 - 19
97575-08550	4 - 10
97780-40012	1 - 3
97880-05025	2 - 18
97885-05012	13 - 23
97980-04112	7 - 15
	19 - 25
98503-04006	4 - 25
98680-05520	14 - 2
99001-06600	17 - 32
99510-10114	2 - 9
	4 - 11

PART NO. NO. PIECES	REF. NO.
------------------------	-------------

F4AMH  
PARTS CATALOGUE  
©2002 by Yamaha Motor Co., Ltd.  
1st Edition, Sep. 2002  
All rights reserved.  
Any reprinting or unauthorized use  
without the written permission of  
Yamaha Motor Co., Ltd.  
is expressly prohibited.  
Printed in Japan

F4AMH  
CATALOGUE DE PIECES DETACHEES  
©2002 Yamaha Motor Co., Ltd.  
1ère Edition, Sept. 2002  
Tous droits réservés.  
Toute réimpression ou utilisation  
sans la permission écrite de la  
Yamaha Motor Co., Ltd.  
est formellement interdite.  
Imprimé en Japon